

(EN) Assembly instructions

(DE) Montageanleitung

(FI) Kokoonpano-ohjeet

(HR) Skupština Upute

(FR) Notice de Montage

(IT) Istruzioni di Montaggio

(BS) Skupština Uputstvo

(NL) Montage Instructies

(CS) Montážní Návod

(RO) Instrucțiuni de Asamblare

(DA) Montagevejledning

(PL) Instrukcja Montażu

(SK) Popis konštrukcie

(SV) Monteringsanvisning

(SL) Navodila za Montažo

(RU) Инструкция по Монтажу

(NO) Montasjeveiledning

(HU) Szerelési útmutató

(UK) Інструкція по монтажу



Vitavia
- makes living grow

VM0009-Z2
6200, 8100, 10000, 11900, 13800, 15700

	Contents Inhalt Indhold	Page Seite Side
	Table of Contents Inhaltsverzeichnis Indholdsfortegnelse	3
	Symbols Symbole Symboler	4 - 5
	Carton part lists Kartonteilelisten Liste over indhold i kartonnen	6 - 43
	EN Safety Warning DE Sicherheitsvorkehrungen DA Sikkerhedsforskrifter EN,DE,FR,NL,DA,SV,IT,SL	44 - 81
S0	Foundation Fundament Fundament	82 - 83
S1	Sill Bars / Corner Posts Grundrahmen u. Eckpfosten Bundramme og hjørnestolper	84 - 90
S2	Middle Bars / Eave Angles Zwischenprofil u. Traufenwinkel Midterprofil og tagrem	92 - 98
S3	Middle Bars Zwischenprofile Mellemprofiler	100 - 102
S4	Roof Dach Tag	104 - 117
S5	Windows Fenster Vinduer	118 - 119
S6	Doors Tür Dør	120 - 127
S7	Glazing Verglasung Glas / Polycarbonatplader	128 - 131
S8	Finishing Abschlussarbeiten Færdiggørelse	132 - 140
S9	Down pipes Regenfallrohre Nedløbsrør	142 - 144

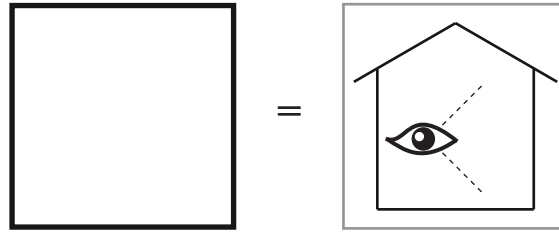

View from Inside
Innenansicht
Set indefra

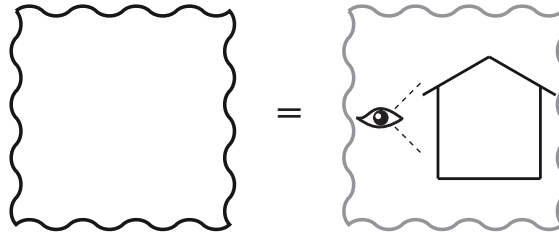

View from Outside
Außenansicht
Set udefra

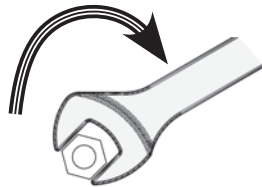

1002
≤ 3Nm

3002
7053
≤ 8Nm

Max. tightening Torque
Max. Drehmoment
Maksimalt moment



Instructions
Anleitung
Instruktion



Look closely / go to
Detail beachten / Siehe auch
Observer nøje / Se også



Mirror of
Spiegelung von
Spejl af



Not included in product!
Nicht im Lieferumfang
enthalten!
Indgår ikke i leverancen!



View from
Blickrichtung
Set fra



Outside
Außenseite
Uden for



Important!
Achtung!
Vigtigt!



Protected location!
Windgeschützter Standort!
Beskyttet placering!



Recycle
Recycelbar
Genbrugeligt



Important Tip
Hinweis
Vigtigt Tip



High Wind
Bei starkem Wind
Vind



Adjust by Hand
Ohne Werkzeug
Brug hænder



x Persons required
x Erforderliche Personen
x Personer, der kræves



Exactly square
Absolut rechtwinklig
Nøjagtig ret vinklet



Step for later
Späterer Schritt
Vises senere



Alternative options
Alternativen
Alternative muligheder



Not required
nicht benötigt
Ikke nødvendig



Incorrect!
Falsch!
Forkert!

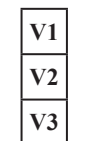

Version 1 to 3
Variante 1 bis 3
Version 1 til 3

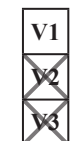

Version 1 only
Nur Variante 1
Kun version 1



Pack Bundle System
Bündelungssystem nach Aufbauschritten
Bundtnumre følger vejledningn

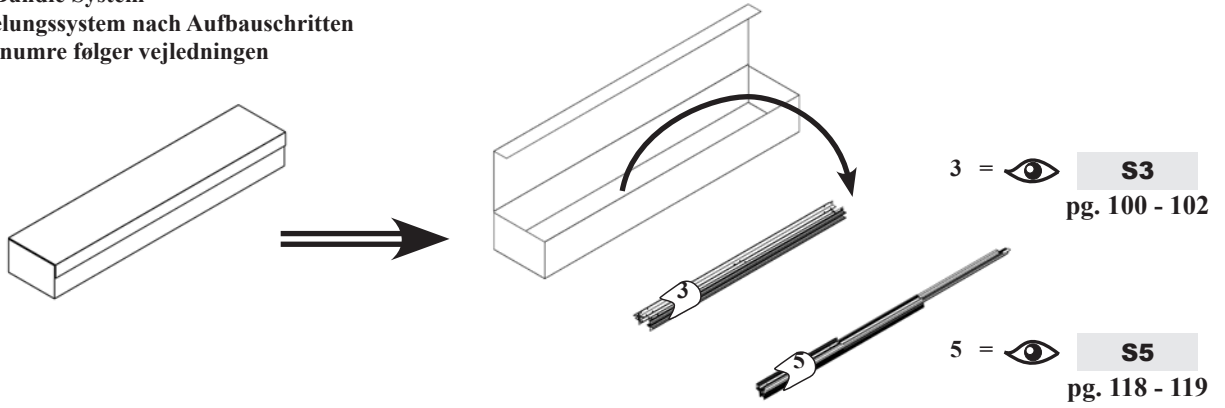

Glazing Options
Verglasung möglicheiten
Forskellige glas muligheder

PC

Polycarbonate
Hohlkammerplatten
Kanal plader i polykarbonat

FPG

Full Pane Glass
Ganze Scheiben
Hele baner

ASP

Aluminium Sandwich Panels
Alu-Sandwich-Paneelen
Sandwichpaneler af aluminium

SPG

Split Pane Glass
Klinkerverglasung
Delt glas

FRG

Frosted Pane Glass
Nörpelglas
Uigennemsigtigt glas



Persons required.



Important!



Go to



Not included in product!



VM0009-Z2

6200 = 8x
8100 = 9x
10000 = 10x

11900 = 11x
13800 = 13x
15700 = 14x

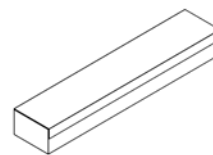







PART LIST, STÜCKLISTE, NOMENCLATURE, ONDERDELENLIJST, STYKLISTE, INNEHÅLL, DELELISTE, OSALUETTELO, ELENCO DEI PEZZI, SEZNAM DÍLŮ, LISTA CZĘŚCI, SEZNAM DELOV, ALKATRÉSZLISTA, POPIS DIJELOVA, LISTA DIJELOVA, LISTA PIESELOR, ZOZNAM ČASTÍ, СПИСОК ДЕТАЛЕЙ, СПИСОК ДЕТАЛЕЙ.

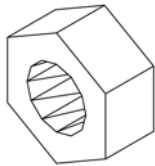
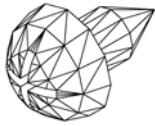

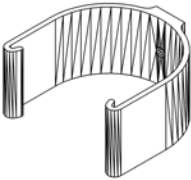

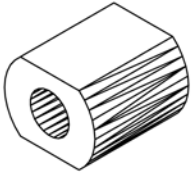

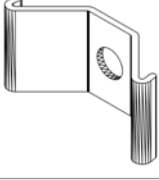
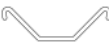
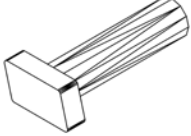
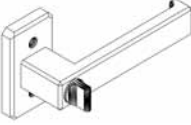
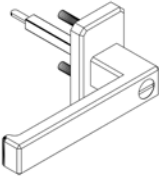

Model : VM0009-Z2							
	QUANTITY						PAGE
	6200	8100	10000	11900	13800	15700	
Pack 1/1 - 1/6 ZE2	1x	1x	1x	1x	1x	1x	7 - 13
Pack 1/1 - 2/6 ZE2	1x	1x	1x	1x	1x	1x	14 - 15
Pack 1/1 - 3/6 ZE2	1x	1x	1x	1x	1x	1x	16
Pack 1/1 - 4/6	1x	1x	1x	1x	1x	1x	17
Pack 1/1 - 5/6	1x	1x	1x	1x	1x	1x	18
Pack 1/1 - 6/6	1x	1x	1x	1x	1x	1x	19
Pack 1/2	-	1x	1x	1x	2x	3x	20
Pack 1F	1x	-	-	-	-	-	21 - 25
Pack 2	1x	2x	1x	-	-	-	26 - 30
Pack 3 - 1/2	-	-	1x	2x	1x	-	31 - 34
Pack 3 - 2/2	-	-	1x	2x	1x	-	35
Pack 4 - 1/2	-	-	-	-	1x	2x	36 - 39
Pack 4 - 2/2	-	-	-	-	1x	2x	40
Pack 5	-	-	-	1x	1x	1x	41 - 42
	8x	9x	10x	11x	13x	14x	



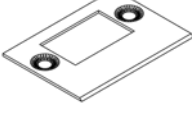

Alternative options

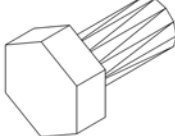

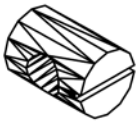
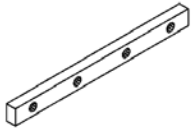

Pack 1/1 - 1/6 ZE2					Required Quantity / Model						
Item No.	Part	Section Ref.	Size mm	Quantity in Carton	6200	8100	10000	11900	13800	15700	Profile
1002		9	M6	2x	2x	2x	2x	2x	2x	2x	
1006		4B 5 6	3.5x6	20x	30x	30x	30x	36x	36x	36x	
1402		9	36	2x	2x	2x	2x	2x	2x	2x	
1403		9	20	2x	2x	2x	2x	2x	2x	2x	
1405		9	15	2x	2x	2x	2x	2x	2x	2x	
1409		9	20	2x	2x	2x	2x	2x	2x	2x	
1412		9	M6x22	2x	2x	2x	2x	2x	2x	2x	
2010		6B	137.55	1x	1x	1x	1x	1x	1x	1x	
2011		6B	137.55	1x	1x	1x	1x	1x	1x	1x	

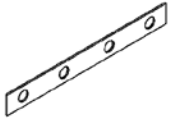
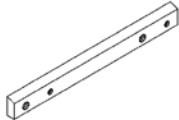
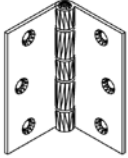
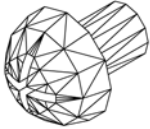
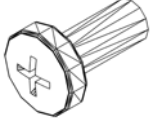

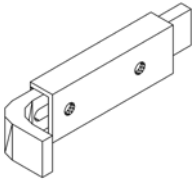
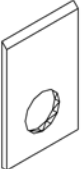
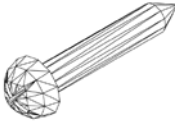
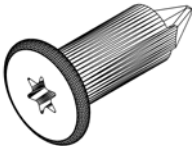
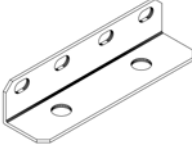

PART LIST, STÜCKLISTE, NOMENCLATURE, ONDERDELENLIJST, STYKLISTE, INNEHÅLL, DELELISTE, OSALUETTELO,
 ELENCO DEI PEZZI, SEZNAM DÍLŮ, LISTA CZĘŚCI, SEZNAM DELOV, ALKATRÉSZLISTA,
 POPIS DIJELOVA, LISTA DIJELOVA, LISTA PIESELOR, ZOZNAM ČASTÍ, СПИСОК ДЕТАЛЕЙ, СПИСОК ДЕТАЛЕЙ.

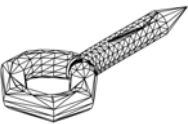
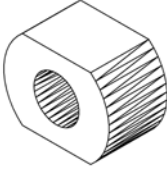
Pack 1/1 - 1/6 ZE2					Required Quantity / Model						
Item No.	Part	Section Ref.	Size mm	Quantity in Carton	6200	8100	10000	11900	13800	15700	Profile
2013		6B	M4 x 40	2x	2x	2x	2x	2x	2x	2x	
2019		6B	43.5	1x	1x	1x	1x	1x	1x	1x	
2020		6B	24 x 58	1x	1x	1x	1x	1x	1x	1x	
2026		8B	41.1 x 53	1x	1x	1x	1x	1x	1x	1x	
6090	PVC 	7B 7C	56000	1x	68500	77000	85500	94000	103000	112000	
7048		4B	M6x80	2x	-	-	1x	2x	2x	2x	
7052		2, 3 4, 5 6, 7A	M6x12	96x	124x	146x	168x	194x	216x	238x	
7053		1, 2 3, 4 5, 6 7, 8B	M6x4	235x	279x	313x	347x	385x	419x	453x	
7054		4B 6	M6x100	8x	12x	12x	12x	14x	14x	14x	

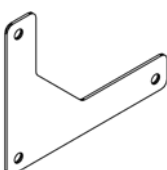
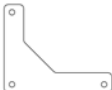

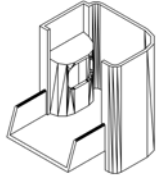
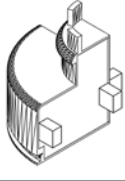
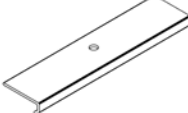

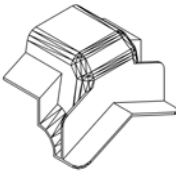
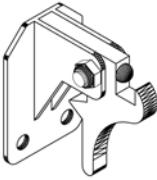
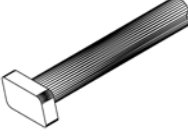
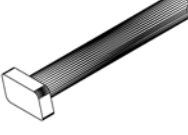
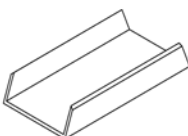

Pack 1/1 - 1/6 ZE2					Required Quantity / Model						
Item No.	Part	Section Ref.	Size mm	Quantity in Carton	6200	8100	10000	11900	13800	15700	Profile
7055		4B 6	M6x10 x14	8x	12x	12x	12x	14x	14x	14x	
7061		117	117	9x	13x	13x	15x	17x	17x	17x	
7062		4	235	4x	5x	6x	7x	8x	9x	10x	
7063		3	255	4x	6x	8x	10x	12x	14x	16x	
7064		1 4A 7A	117	1x	5x	5x	5x	5x	5x	5x	
7065		4A	140	2x	2x	2x	2x	2x	2x	2x	
7066		6	75	4x	4x	4x	4x	4x	4x	4x	
7080		1 4A 7A	M6x8	36x	52x	52x	60x	68x	68x	68x	
7081		4A	M5x13	4x	4x	4x	4x	4x	4x	4x	

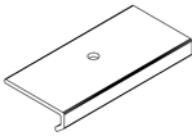

**PART LIST, STÜCKLISTE, NOMENCLATURE, ONDERDELENLIJST, STYKLISTE, INNEHÅLL, DELELISTE, OSALUETTELO,
ELENCO DEI PEZZI, SEZNAM DÍLŮ, LISTA CZĘŚCI, SEZNAM DELOV, ALKATRÉSZLISTA,
POPIS DIJELOVA, LISTA DIJELOVA, LISTA PIESELOR, ZOZNAM ČASTÍ, СПИСОК ДЕТАЛЕЙ, СПИСОК ДЕТАЛЕЙ.**

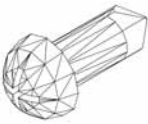
Pack 1/1 - 1/6 ZE2					Required Quantity / Model						
Item No.	Part	Section Ref.	Size mm	Quantity in Carton	6200	8100	10000	11900	13800	15700	Profile
7085		6A	95	1x	1x	1x	1x	1x	1x	1x	
7086		6B	23	1x	1x	1x	1x	1x	1x	1x	
7087		6A	5x30	2x	2x	2x	2x	2x	2x	2x	
7088		6 8	4.2x13	38x	34x	34x	34x	34x	34x	34x	
7095		1	117	8x	8x	8x	10x	12x	12x	12x	
7111		8B	35	1x	1x	1x	1x	1x	1x	1x	
7112		8B	8	1x	1x	1x	1x	1x	1x	1x	
7113		8B	100	1x	1x	1x	1x	1x	1x	1x	
7114		6	138	4x	4x	4x	4x	4x	4x	4x	

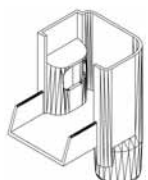
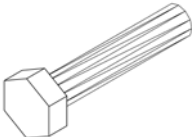
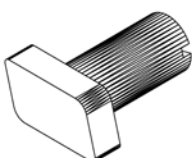
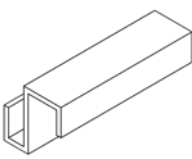
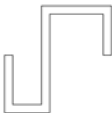
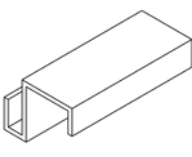
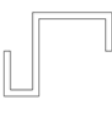
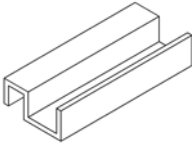



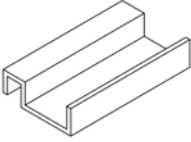





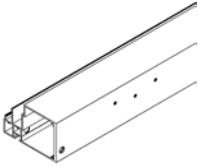

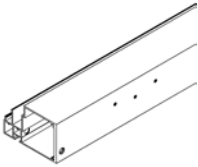
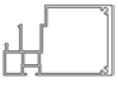
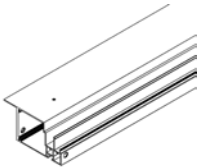
Pack 1/1 - 1/6 ZE2					Required Quantity / Model						
Item No.	Part	Section Ref.	Size mm	Quantity in Carton	6200	8100	10000	11900	13800	15700	Profile
7128		8A	71	1x	1x	1x	1x	1x	1x	1x	
7129		8A	71	1x	1x	1x	1x	1x	1x	1x	
7200		1	62	4x	4x	4x	4x	4x	4x	4x	
7240		7A	88	2x	2x	2x	2x	2x	2x	2x	
7266		8A	91	2x	2x	2x	2x	2x	2x	2x	
7283		8B	60	1x	1x	1x	1x	1x	1x	1x	
7288		7C	M6x38	10x	10x	10x	10x	10x	10x	10x	
7289		7B 7C	M6x42	112x	116x	126x	136x	146x	156x	166x	
7292		7A	100	2x	2x	2x	2x	2x	2x	2x	

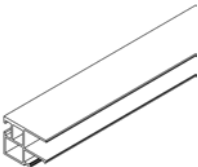
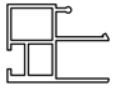
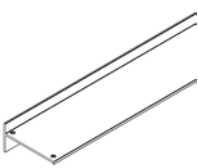



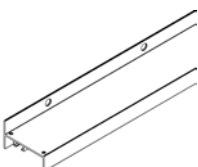

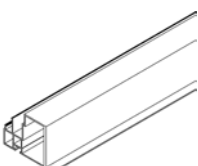
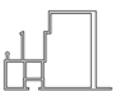
PART LIST, STÜCKLISTE, NOMENCLATURE, ONDERDELENLIJST, STYKLISTE, INNEHÅLL, DELELISTE, OSALUETTELO,
 ELENCO DEI PEZZI, SEZNAM DÍLŮ, LISTA CZĘŚCI, SEZNAM DELOV, ALKATRÉSZLISTA,
 POPIS DIJELOVA, LISTA DIJELOVA, LISTA PIESELOR, ZOZNAM ČASTÍ, СПИСОК ДЕТАЛЕЙ, СПИСОК ДЕТАЛЕЙ.

Pack 1/1 - 1/6 ZE2					Required Quantity / Model						
Item No.	Part	Section Ref.	Size mm	Quantity in Carton	6200	8100	10000	11900	13800	15700	Profile
7342		7A	45	4x	4x	4x	4x	4x	4x	4x	
7349		7A* 8A 9	3.9x10	8x	40x	52x	64x	76x	88x	100x	
7370		8A	71	1x	1x	1x	1x	1x	1x	1x	
7371		8A	71	1x	1x	1x	1x	1x	1x	1x	
7390		2	M6x30	4x	4x	4x	4x	4x	4x	4x	
7399		1 8B	M6x12	13x	11x	11x	11x	11x	11x	11x	
7406		7B	30	6x	12x	14x	16x	18x	20x	22x	
7407		7B	30	6x	12x	14x	16x	18x	20x	22x	
7408		7B	30	8x	8x	8x	8x	8x	8x	8x	

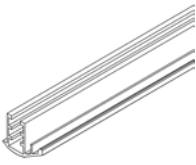

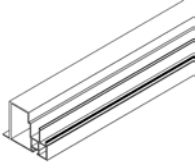
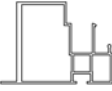
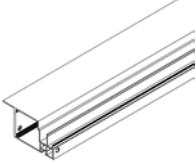

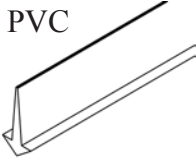

Pack 1/1 - 1/6 ZE2					Required Quantity / Model						
Item No.	Part	Section Ref.	Size mm	Quantity in Carton	6200	8100	10000	11900	13800	15700	Profile
7409		7B	30	8x	8x	8x	8x	8x	8x	8x	
7497	ACRYLIC 	7A	55000	1x	4700	6200	7700	9200	10700	12200	



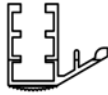
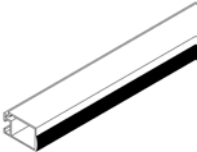
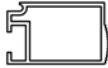
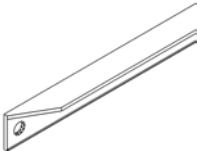



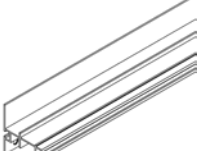
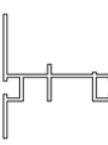
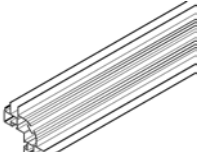

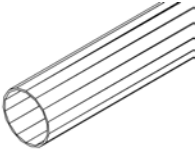

**PART LIST, STÜCKLISTE, NOMENCLATURE, ONDERDELENLIJST, STYKLISTE, INNEHÅLL, DELELISTE, OSALUETTELO,
ELENCO DEI PEZZI, SEZNAM DÍLŮ, LISTA CZĘŚCI, SEZNAM DELOV, ALKATRÉSZLISTA,
POPIS DIJELOVA, LISTA DIJELOVA, LISTA PIESELOR, ZOZNAM ČASTÍ, СПИСОК ДЕТАЛЕЙ, СПИСОК ДЕТАЛЕЙ.**

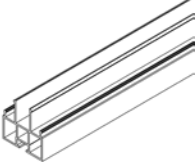
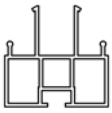
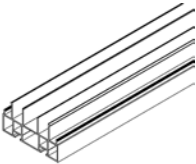
Pack 1/1 - 2/6 ZE2					Required Quantity / Model						Profile
Item No.	Part	Section Ref.	Size mm	Quantity in Carton	6200	8100	10000	11900	13800	15700	
7015		6B	1000	1x	1x	1x	1x	1x	1x	1x	
7017		6A	717	1x	1x	1x	1x	1x	1x	1x	
7018		6A	717	1x	1x	1x	1x	1x	1x	1x	
7022		6A 6B	708	4x	4x	4x	4x	4x	4x	4x	
7023		6B	850	1x	1x	1x	1x	1x	1x	1x	
7024		6A	850	1x	1x	1x	1x	1x	1x	1x	
7025		6A 6B	850	2x	2x	2x	2x	2x	2x	2x	
7029		2	1775	1x	1x	1x	1x	1x	1x	1x	
7031		7C	996	2x	2x	2x	2x	2x	2x	2x	

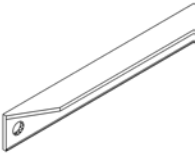

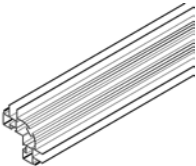
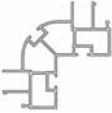
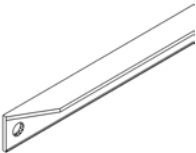

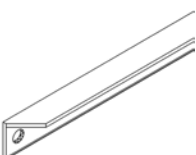



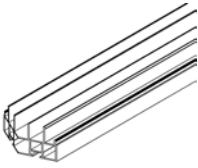

Pack 1/1 - 2/6 ZE2					Required Quantity / Model						
Item No.	Part	Section Ref.	Size mm	Quantity in Carton	6200	8100	10000	11900	13800	15700	Profile
7035		7C	713	2x	2x	2x	2x	2x	2x	2x	
7045		2	1775	1x	1x	1x	1x	1x	1x	1x	
7079		6B	1000	1x	1x	1x	1x	1x	1x	1x	
7083	PVC 	6A 6B	900	2x	2x	2x	2x	2x	2x	2x	

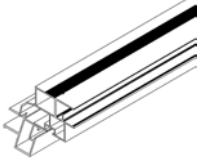

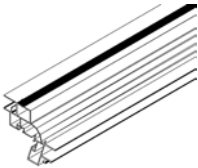

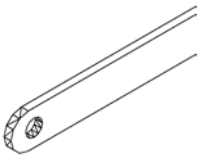

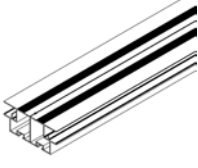



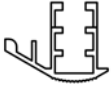



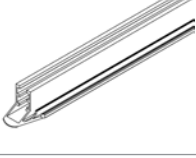

**PART LIST, STÜCKLISTE, NOMENCLATURE, ONDERDELENLIJST, STYKLISTE, INNEHÅLL, DELELISTE, OSALUETTELO,
ELENCO DEI PEZZI, SEZNAM DÍLŮ, LISTA CZĘŚCI, SEZNAM DELOV, ALKATRÉSZLISTA,
POPIS DIJELOVA, LISTA DIJELOVA, LISTA PIESELOR, ZOZNAM ČASTÍ, СПИСОК ДЕТАЛЕЙ, СПИСОК ДЕТАЛЕЙ.**

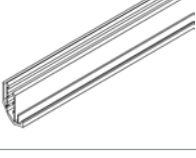
Pack 1/1 - 3/6 ZE2					Required Quantity / Model						Profile
Item No.	Part	Section Ref.	Size mm	Quantity in Carton	6200	8100	10000	11900	13800	15700	
7034		7B 7C	733	6x	14x	16x	18x	20x	22x	24x	
7036		2	922	1x	1x	1x	1x	1x	1x	1x	
7069		2	1924	2x	4x	4x	4x	4x	4x	4x	
7133		1	2460	2x	1x	1x	1x	1x	1x	1x	
7134		2	2459	2x	1x	1x	1x	1x	1x	1x	
7236		1	1775	2x	4x	4x	4x	4x	4x	4x	





Pack 1/1 - 4/6					Required Quantity / Model						
Item No.	Part	Section Ref.	Size mm	Quantity in Carton	6200	8100	10000	11900	13800	15700	Profile
1415		9	1720	2x	2x	2x	2x	2x	2x	2x	
7005		3	1775	2x	4x	6x	8x	10x	12x	14x	
7006		2	1775	3x	3x	3x	3x	3x	3x	3x	
7069		2	1924	2x	2x	2x	2x	2x	2x	2x	
7236		1	1775	2x	4x	4x	4x	4x	4x	4x	
7269		2	1926	4x	4x	4x	4x	4x	4x	4x	
7295		4A	1531.5	4x	4x	4x	4x	4x	4x	4x	





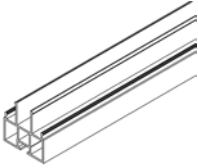
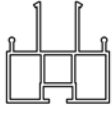

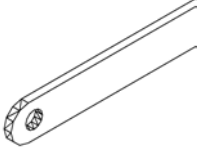

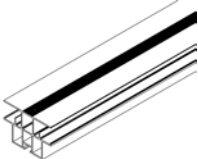
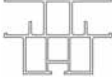
**PART LIST, STÜCKLISTE, NOMENCLATURE, ONDERDELENLIJST, STYKLISTE, INNEHÅLL, DELELISTE, OSALUETTELO,
ELENCO DEI PEZZI, SEZNAM DÍLŮ, LISTA CZĘŚCI, SEZNAM DELOV, ALKATRÉSZLISTA,
POPIS DIJELOVA, LISTA DIJELOVA, LISTA PIESELOR, ZOZNAM ČASTÍ, СПИСОК ДЕТАЛЕЙ, СПИСОК ДЕТАЛЕЙ.**

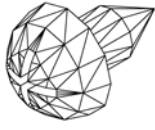
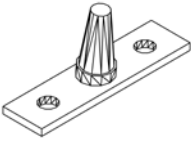
Pack 1/1 - 5/6					Required Quantity / Model						
Item No.	Part	Section Ref.	Size mm	Quantity in Carton	6200	8100	10000	11900	13800	15700	Profile
7219		3	569.5	2x	2x	2x	2x	2x	2x	2x	
7237		4A	1362	2x	2x	2x	2x	2x	2x	2x	
7238		4A	1362	2x	2x	2x	2x	2x	2x	2x	
7249		4B	1251	1x	2x	3x	4x	5x	6x	7x	
7256		4A	1356	2x	2x	2x	2x	2x	2x	2x	

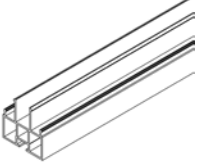
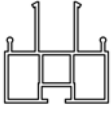

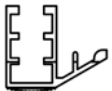
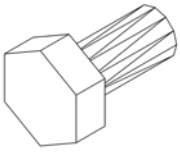

Pack 1/1 - 6/6					Required Quantity / Model						
Item No.	Part	Section Ref.	Size mm	Quantity in Carton	6200	8100	10000	11900	13800	15700	Profile
7030		7B	1793	2x	2x	2x	2x	2x	2x	2x	
7032		7B	1793	2x	4x	6x	8x	10x	12x	14x	
7033		7B	1793	14x	14x	14x	14x	14x	14x	14x	
7034		7B	733	2x	8x	10x	12x	14x	16x	18x	
7044		7B	443	2x	4x	4x	4x	4x	4x	4x	
7074		7B	1369	2x	2x	2x	2x	2x	2x	2x	
7075		7B	1369	2x	2x	2x	2x	2x	2x	2x	
7276		7B	582	2x	2x	2x	2x	2x	2x	2x	
7277		7B	582	2x	2x	2x	2x	2x	2x	2x	





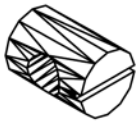
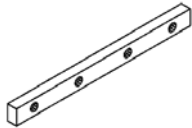
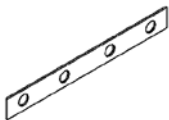
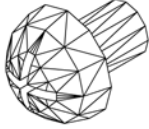
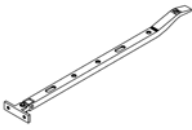
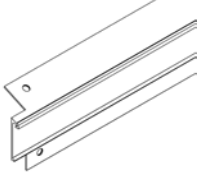

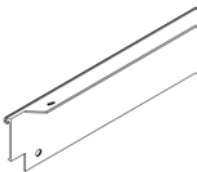

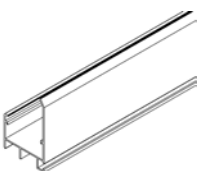
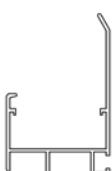
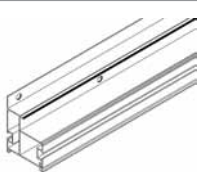
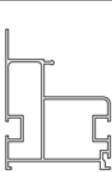

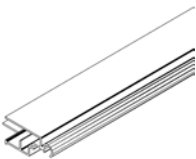

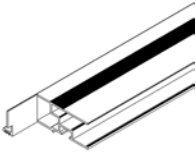
**PART LIST, STÜCKLISTE, NOMENCLATURE, ONDERDELENLIJST, STYKLISTE, INNEHÅLL, DELELISTE, OSALUETTELO,
ELENCO DEI PEZZI, SEZNAM DÍLŮ, LISTA CZĘŚCI, SEZNAM DELOV, ALKATRÉSZLISTA,
POPIS DIJELOVA, LISTA DIJELOVA, LISTA PIESELOR, ZOZNAM ČASTÍ, СПИСОК ДЕТАЛЕЙ, СПИСОК ДЕТАЛЕЙ.**

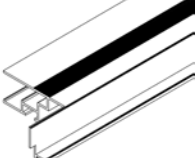
Pack 1/2					Required Quantity / Model						
Item No.	Part	Section Ref.	Size mm	Quantity in Carton	6200	8100	10000	11900	13800	15700	Profile
7005		3	1775	4x	4x	6x	8x	10x	12x	14x	
7032		7B	1793	4x	4x	6x	8x	10x	12x	14x	
7249		4B	1251	2x	2x	3x	4x	5x	6x	7x	
7255		4B	1356	4x	2x	4x	6x	8x	10x	12x	

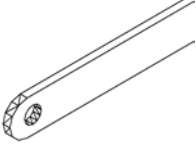

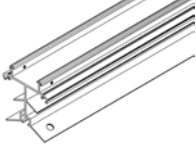
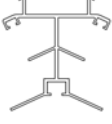
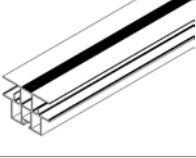
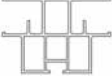
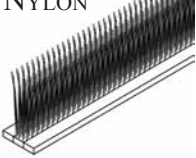

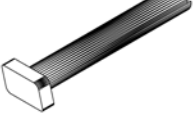
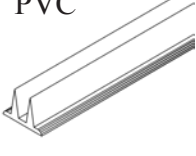





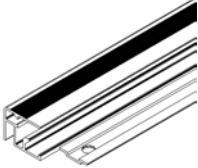

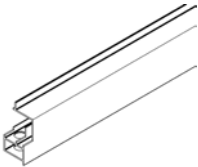
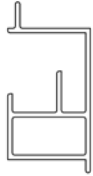

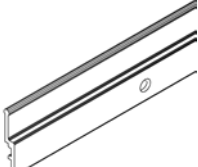
Pack 1F					Required Quantity / Model						
Item No.	Part	Section Ref.	Size mm	Quantity in Carton	6200	8100	10000	11900	13800	15700	Profile
1006		4B 5 6	3.5x6	6x	30x	30x	30x	36x	36x	36x	
6056		4B	46	2x	4x	4x	4x	6x	6x	6x	
6090	PVC 	7B 7C	2000	1x	68500	77000	85500	94000	103000	112000	
7005		3	1775	2x	4x	6x	8x	10x	12x	14x	
7032		7B	1793	2x	4x	6x	8x	10x	12x	14x	
7034		7B	733	2x	8x	10x	12x	14x	16x	18x	
7052		2, 3 4, 5 6, 7A	M6x12	8x	126x	148x	170x	196x	218x	240x	
7053		1, 2 3, 4 5, 6 7, 8	M6x4	13x	270x	302x	334x	370x	402x	434x	
7054		4B 6	M6x100	2x	12x	12x	12x	14x	14x	14x	

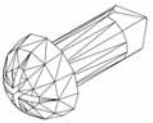
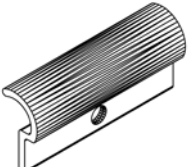

**PART LIST, STÜCKLISTE, NOMENCLATURE, ONDERDELENLIJST, STYKLISTE, INNEHÅLL, DELELISTE, OSALUETTELO,
ELENCO DEI PEZZI, SEZNAM DÍLŮ, LISTA CZĘŚCI, SEZNAM DELOV, ALKATRÉSZLISTA,
POPIS DIJELOVA, LISTA DIJELOVA, LISTA PIESELOR, ZOZNAM ČASTÍ, СПИСОК ДЕТАЛЕЙ, СПИСОК ДЕТАЛЕЙ.**

Pack 1F					Required Quantity / Model						
Item No.	Part	Section Ref.	Size mm	Quantity in Carton	6200	8100	10000	11900	13800	15700	Profile
7055		4B 6	M6x10 x14	2x	12x	12x	12x	14x	14x	14x	
7061		1 4A 7A	117	2x	13x	13x	15x	17x	17x	17x	
7064		1 4A 7A	117	2x	5x	5x	5x	5x	5x	5x	
7080		1 4A 7A	M6x8	8x	52x	52x	60x	68x	68x	68x	
7090		5	324	1x	2x	2x	2x	3x	3x	3x	
7221		2	795	1x	1x	-	-	-	-	-	
7222		2	795	1x	1x	-	-	-	-	-	
7223		7A	795	2x	2x	-	-	-	-	-	
7225		1	776	2x	2x	-	-	-	-	-	

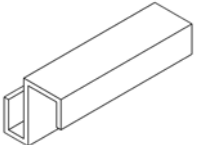



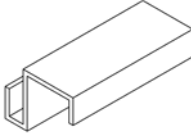

Pack 1F					Required Quantity / Model						
Item No.	Part	Section Ref.	Size mm	Quantity in Carton	6200	8100	10000	11900	13800	15700	Profile
7244		5	713	1x	2x	2x	2x	3x	3x	3x	
7247 (7291)		5	674	1x	2x	2x	2x	3x	3x	3x	
7248 (7291)		5	674	1x	2x	2x	2x	3x	3x	3x	
7249		4B	1251	1x	2x	3x	4x	5x	6x	7x	
7253		4A	776	1x	1x	-	-	-	-	-	
7255		4B	1356	2x	2x	4x	6x	8x	10x	12x	
7260	NYLON 	4A	776	2x	2x	-	-	-	-	-	
7289		7B 7C	M6x42	5x	126x	136x	146x	156x	166x	176x	
7291 (7247 & 7248)	PVC 	5	674	2x	4x	4x	4x	6x	6x	6x	



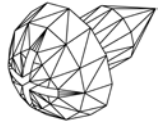
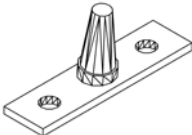
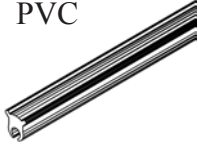

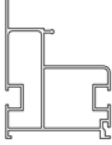
PART LIST, STÜCKLISTE, NOMENCLATURE, ONDERDELENLIJST, STYKLISTE, INNEHÅLL, DELELISTE, OSALUETTELO, ELENCO DEI PEZZI, SEZNAM DÍLŮ, LISTA CZĘŚCI, SEZNAM DELOV, ALKATRÉSZLISTA, POPIS DIJELOVA, LISTA DIJELOVA, LISTA PIESELOR, ZOZNAM ČASTÍ, СПИСОК ДЕТАЛЕЙ, СПИСОК ДЕТАЛЕЙ.

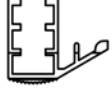
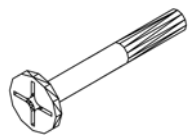
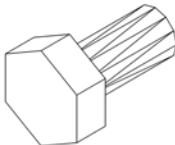
Item No.	Pack 1F				Required Quantity / Model						Profile
	Part	Section Ref.	Size mm	Quantity in Carton	6200	8100	10000	11900	13800	15700	
7293		5	713	1x	2x	2x	2x	3x	3x	3x	
7294		4B	708	1x	2x	2x	2x	3x	3x	3x	
7296		7A	707	2x	6x	8x	10x	12x	14x	16x	
7297		7A	687	2x	6x	8x	10x	12x	14x	16x	
7298		7A*	30	3x	4x +6x*	6x +8x*	8x +10x*	9x +12x*	11x +14x*	13x +16x*	
7299		7A*	30	3x	4x +6x*	6x +8x*	8x +10x*	9x +12x*	11x +14x*	13x +16x*	
7349		7A* 8	3.9x10	11x	40x	52x	64x	76x	88x	100x	
7369		8	30	2x	4x	4x	4x	6x	6x	6x	
7406		7B	30	2x	12x	14x	16x	18x	20x	22x	



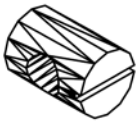
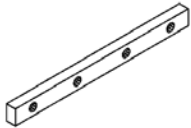

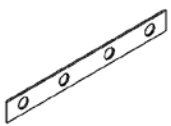
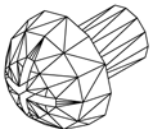
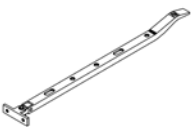
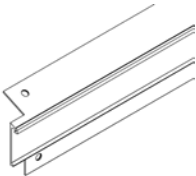
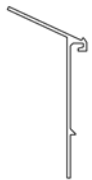
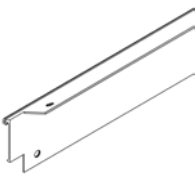

Pack 1F					Required Quantity / Model						
Item No.	Part	Section Ref.	Size mm	Quantity in Carton	6200	8100	10000	11900	13800	15700	Profile
7407		7B	30	2x	12x	14x	16x	18x	20x	22x	



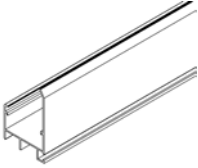
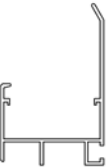
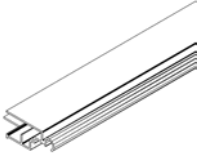

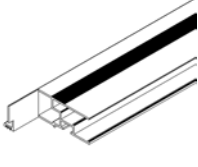
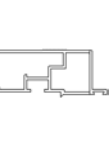
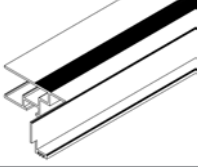
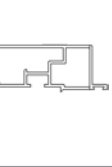
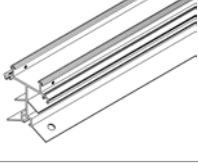
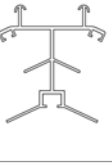
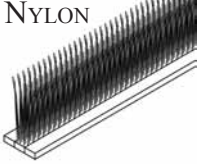

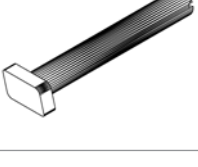
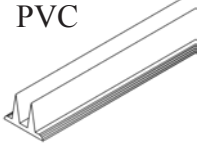
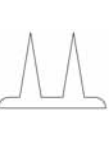
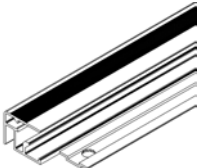



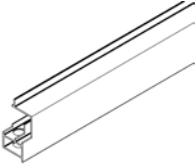
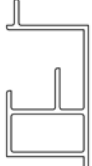

PART LIST, STÜCKLISTE, NOMENCLATURE, ONDERDELENLIJST, STYKLISTE, INNEHÅLL, DELELISTE, OSALUETTELO, ELENCO DEI PEZZI, SEZNAM DÍLŮ, LISTA CZĘŚCI, SEZNAM DELOV, ALKATRÉSZLISTA, POPIS DIJELOVA, LISTA DIJELOVA, LISTA PIESELOR, ZOZNAM ČASTÍ, СПИСОК ДЕТАЛЕЙ, СПИСОК ДЕТАЛЕЙ.

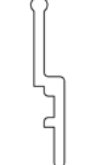
Pack 2					Required Quantity / Model						Profile
Item No.	Part	Section Ref.	Size mm	Quantity in Carton	6200	8100	10000	11900	13800	15700	
1006		4B 5 6	3.5x6	6x	30x	30x	30x	36x	36x	36x	
6056		4B	46	2x	4x	4x	4x	6x	6x	6x	
6090	PVC 	7B 7C	10500	1x	68500	77000	85500	94000	103000	112000	
7001		1	1520	2x	2x	4x	2x	-	-	-	
7034		7B	733	4x	8x	10x	12x	14x	16x	18x	
7047		4B	M6x48	1x	-	2x	4x	4x	6x	8x	
7052		2, 3 4, 5 6, 7A	M6x12	30x	126x	148x	170x	196x	218x	240x	
7053		1, 2 3, 4 5, 6 7, 8	M6x4	45x	270x	302x	334x	370x	402x	434x	
7054		4B 6	M6x100	2x	12x	12x	12x	14x	14x	14x	

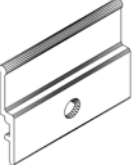
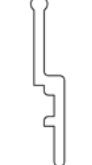
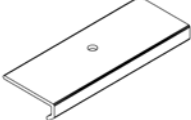

Pack 2					Required Quantity / Model						
Item No.	Part	Section Ref.	Size mm	Quantity in Carton	6200	8100	10000	11900	13800	15700	Profile
7055		4B 6	M6x10 x14	2x	12x	12x	12x	14x	14x	14x	
7061		1 4A 7A	117	2x	13x	13x	15x	17x	17x	17x	
7062		4	235	1x	5x	6x	7x	8x	9x	10x	
7063		4	255	2x	6x	8x	10x	12x	14x	16x	
7064		1 4A 7A	117	2x	5x	5x	5x	5x	5x	5x	
7080		1 4A 7A	M6x8	8x	52x	52x	60x	68x	68x	68x	
7090		5	324	1x	2x	2x	2x	3x	3x	3x	
7201		2	1539	1x	1x	2x	1x	-	-	-	
7202		2	1539	1x	1x	2x	1x	-	-	-	

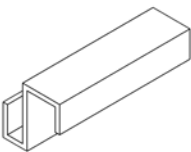



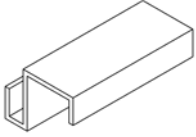

PART LIST, STÜCKLISTE, NOMENCLATURE, ONDERDELENLIJST, STYKLISTE, INNEHÅLL, DELELISTE, OSALUETTELO, ELENCO DEI PEZZI, SEZNAM DÍLŮ, LISTA CZĘŚCI, SEZNAM DELOV, ALKATRÉSZLISTA, POPIS DIJELOVA, LISTA DIJELOVA, LISTA PIESELOR, ZOZNAM ČASTÍ, СПИСОК ДЕТАЛЕЙ, СПИСОК ДЕТАЛЕЙ.

Pack 2					Required Quantity / Model						Profile
Item No.	Part	Section Ref.	Size mm	Quantity in Carton	6200	8100	10000	11900	13800	15700	
7213		7A	1539	2x	2x	4x	2x	-	-	-	
7244		5	713	1x	2x	2x	2x	3x	3x	3x	
7247 (7291)		5	674	1x	2x	2x	2x	3x	3x	3x	
7248 (7291)		5	674	1x	2x	2x	2x	3x	3x	3x	
7250		4A	1520	1x	1x	2x	1x	-	-	-	
7257	NYLON 	4A	1520	2x	2x	4x	2x	-	-	-	
7289		7B 7C	M6x42	15x	126x	136x	146x	156x	166x	176x	
7291 (7247 & 7248)	PVC 	5	674	2x	4x	4x	4x	6x	6x	6x	
7293		5	713	1x	2x	2x	2x	3x	3x	3x	

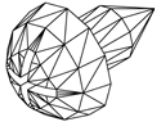
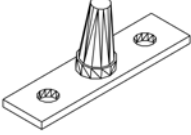
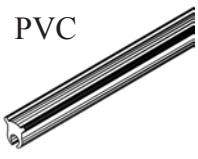

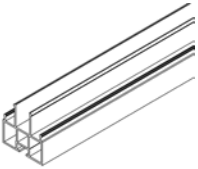
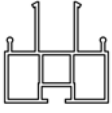

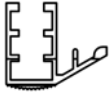
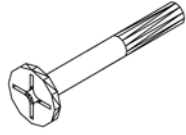
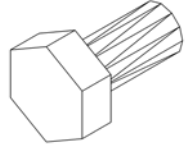



Pack 2					Required Quantity / Model						
Item No.	Part	Section Ref.	Size mm	Quantity in Carton	6200	8100	10000	11900	13800	15700	Profile
7294		4B	708	1x	2x	2x	2x	3x	3x	3x	
7296		7A	707	4x	6x	8x	10x	12x	14x	16x	
7297		7A	687	4x	6x	8x	10x	12x	14x	16x	
7298		7A*	30	7x	4x +6x*	6x +8x*	8x +10x*	9x +12x*	11x +14x*	13x +16x*	
7299		7A*	30	7x	4x +6x*	6x +8x*	8x +10x*	9x +12x*	11x +14x*	13x +16x*	
7343		7A	56	2x	2x	4x	6x	8x	10x	12x	
7349		7A* 8	3.9x10	23x	40x	52x	64x	76x	88x	100x	
7369		8	30	2x	4x	4x	4x	6x	6x	6x	
7406		7B	30	4x	12x	14x	16x	18x	20x	22x	

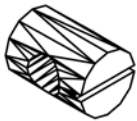
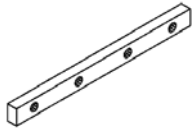

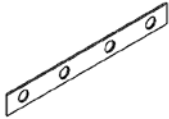
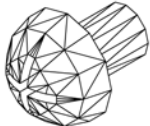

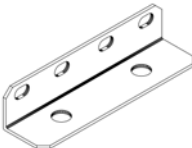

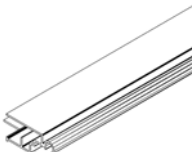



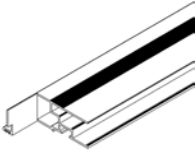

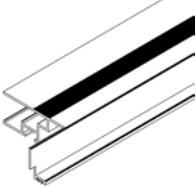
**PART LIST, STÜCKLISTE, NOMENCLATURE, ONDERDELENLIJST, STYKLISTE, INNEHÅLL, DELELISTE, OSALUETTELO,
ELENCO DEI PEZZI, SEZNAM DÍLŮ, LISTA CZĘŚCI, SEZNAM DELOV, ALKATRÉSZLISTA,
POPIS DIJELOVA, LISTA DIJELOVA, LISTA PIESELOR, ZOZNAM ČASTÍ, СПИСОК ДЕТАЛЕЙ, СПИСОК ДЕТАЛЕЙ.**

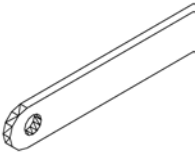
Pack 2					Required Quantity / Model						
Item No.	Part	Section Ref.	Size mm	Quantity in Carton	6200	8100	10000	11900	13800	15700	Profile
7407		7B	30	4x	12x	14x	16x	18x	20x	22x	

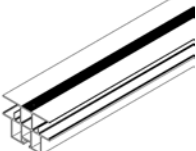
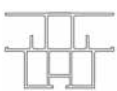
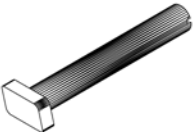
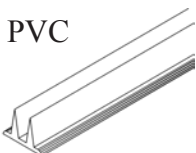

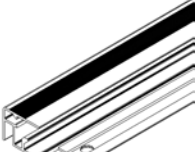

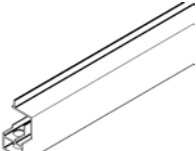
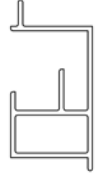





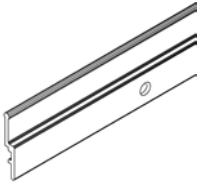

Pack 3 - 1/2					Required Quantity / Model						
Item No.	Part	Section Ref.	Size mm	Quantity in Carton	6200	8100	10000	11900	13800	15700	Profile
1006		4B 5 6	3.5x6	6x	30x	30x	30x	36x	36x	36x	
6056		4B	46	2x	4x	4x	4x	6x	6x	6x	
6090	PVC 	7B 7C	19000	1x	68500	77000	85500	94000	103000	112000	
7005		3	1775	2x	4x	6x	8x	10x	12x	14x	
7034		7B	733	6x	8x	10x	12x	14x	16x	18x	
7047		4B	M6x48	3x	-	2x	4x	4x	6x	8x	
7052		2, 3 4, 5 6, 7A	M6x12	52x	126x	148x	170x	196x	218x	240x	
7053		1, 2 3, 4 5, 6 7, 8	M6x4	77x	270x	302x	334x	370x	402x	434x	
7054		4B 6	M6x100	2x	12x	12x	12x	14x	14x	14x	



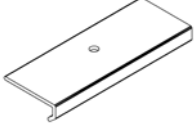

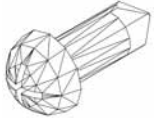
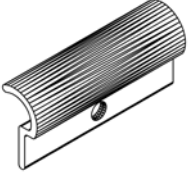

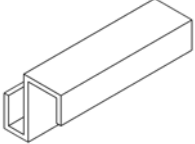

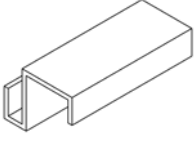
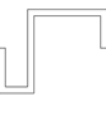

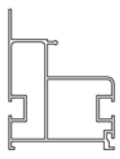
**PART LIST, STÜCKLISTE, NOMENCLATURE, ONDERDELENLIJST, STYKLISTE, INNEHÅLL, DELELISTE, OSALUETTELO,
ELENCO DEI PEZZI, SEZNAM DÍLŮ, LISTA CZĘŚCI, SEZNAM DELOV, ALKATRÉSZLISTA,
POPIS DIJELOVA, LISTA DIJELOVA, LISTA PIESELOR, ZOZNAM ČASTÍ, СПИСОК ДЕТАЛЕЙ, СПИСОК ДЕТАЛЕЙ.**

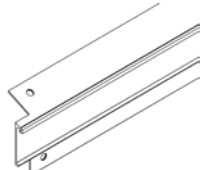
Pack 3 - 1/2					Required Quantity / Model						
Item No.	Part	Section Ref.	Size mm	Quantity in Carton	6200	8100	10000	11900	13800	15700	Profile
7055		4B 6	M6x10 x14	2x	12x	12x	12x	14x	14x	14x	
7061		1 4A 7A	117	4x	13x	13x	15x	17x	17x	17x	
7062		4	235	2x	5x	6x	7x	8x	9x	10x	
7063		4	255	4x	6x	8x	10x	12x	14x	16x	
7064		1 4A 7A	117	2x	5x	5x	5x	5x	5x	5x	
7080		1 4A 7A	M6x8	16x	52x	52x	60x	68x	68x	68x	
7090		5	324	1x	2x	2x	2x	3x	3x	3x	
7095		1	117	2x	8x	8x	10x	12x	12x	12x	
7244		5	713	1x	2x	2x	2x	3x	3x	3x	

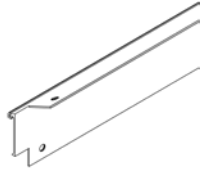

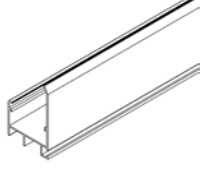
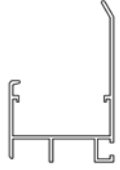
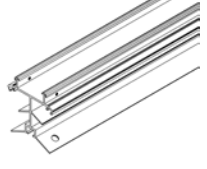

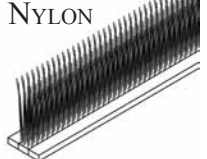

Pack 3 - 1/2					Required Quantity / Model						
Item No.	Part	Section Ref.	Size mm	Quantity in Carton	6200	8100	10000	11900	13800	15700	Profile
7247 (7291)		5	674	1x	2x	2x	2x	3x	3x	3x	
7248 (7291)		5	674	1x	2x	2x	2x	3x	3x	3x	
7249		4B	1251	1x	2x	3x	4x	5x	6x	7x	
7255		4B	1356	2x	2x	4x	6x	8x	10x	12x	
7289		7B 7C	M6x42	25x	126x	136x	146x	156x	166x	176x	
7291 (7247 & 7248)	PVC 	5	674	2x	4x	4x	4x	6x	6x	6x	
7293		5	713	1x	2x	2x	2x	3x	3x	3x	
7294		4B	708	1x	2x	2x	2x	3x	3x	3x	
7296		7A	707	6x	6x	8x	10x	12x	14x	16x	



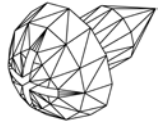
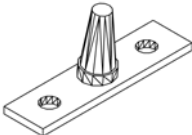



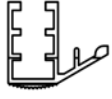
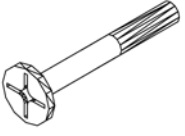
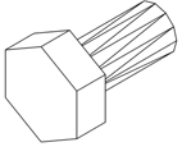

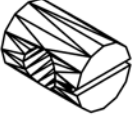
**PART LIST, STÜCKLISTE, NOMENCLATURE, ONDERDELENLIJST, STYKLISTE, INNEHÅLL, DELELISTE, OSALUETTELO,
ELENCO DEI PEZZI, SEZNAM DÍLŮ, LISTA CZĘŚCI, SEZNAM DELOV, ALKATRÉSZLISTA,
POPIS DIJELOVA, LISTA DIJELOVA, LISTA PIESELOR, ZOZNAM ČASTÍ, СПИСОК ДЕТАЛЕЙ, СПИСОК ДЕТАЛЕЙ.**

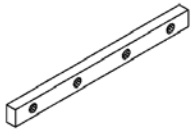
Pack 3 - 1/2					Required Quantity / Model						Profile
Item No.	Part	Section Ref.	Size mm	Quantity in Carton	6200	8100	10000	11900	13800	15700	
7297		7A	687	6x	6x	8x	10x	12x	14x	16x	
7298		7A*	30	11x	4x +6x*	6x +8x*	8x +10x*	9x +12x*	11x +14x*	13x +16x*	
7299		7A*	30	11x	4x +6x*	6x +8x*	8x +10x*	9x +12x*	11x +14x*	13x +16x*	
7343		7A	56	4x	2x	4x	6x	8x	10x	12x	
7349		7A* 8	3.9x10	34x	40x	52x	64x	76x	88x	100x	
7369		8	30	2x	4x	4x	4x	6x	6x	6x	
7406		7B	30	6x	12x	14x	16x	18x	20x	22x	
7407		7B	30	6x	12x	14x	16x	18x	20x	22x	

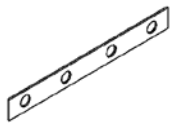
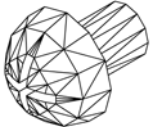

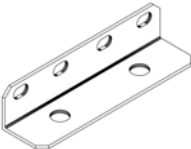



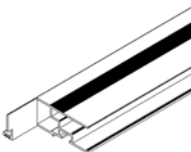
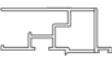



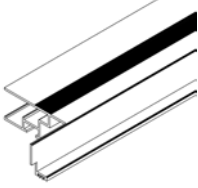

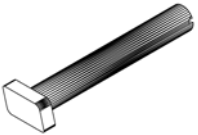
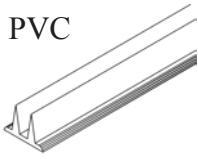

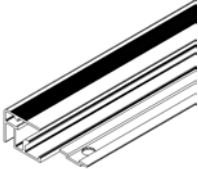
Pack 3 - 2/2					Required Quantity / Model						
Item No.	Part	Section Ref.	Size mm	Quantity in Carton	6200	8100	10000	11900	13800	15700	Profile
7002		1	2264	2x	-	-	2x	4x	2x	-	
7032		7B	1793	2x	4x	6x	8x	10x	12x	14x	
7203		2	2283	1x	-	-	1x	2x	1x	-	
7204		2	2283	1x	-	-	1x	2x	1x	-	
7214		7A	2283	2x	-	-	2x	4x	2x	-	
7251		4A	2264	1x	-	-	1x	2x	1x	-	
7258	NYLON 	4A	2264	2x	-	-	2x	4x	2x	-	

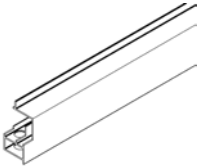
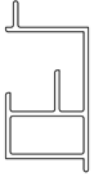

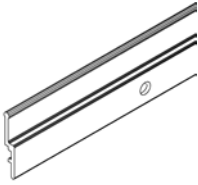

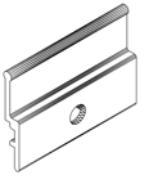

**PART LIST, STÜCKLISTE, NOMENCLATURE, ONDERDELENLIJST, STYKLISTE, INNEHÅLL, DELELISTE, OSALUETTELO,
ELENCO DEI PEZZI, SEZNAM DÍLŮ, LISTA CZĘŚCI, SEZNAM DELOV, ALKATRÉSZLISTA,
POPIS DIJELOVA, LISTA DIJELOVA, LISTA PIESELOR, ZOZNAM ČASTÍ, СПИСОК ДЕТАЛЕЙ, СПИСОК ДЕТАЛЕЙ.**

Pack 4 - 1/2					Required Quantity / Model						
Item No.	Part	Section Ref.	Size mm	Quantity in Carton	6200	8100	10000	11900	13800	15700	Profile
1006		4B 5 6	3.5x6	6x	30x	30x	30x	36x	36x	36x	
6056		4B	46	2x	4x	4x	4x	6x	6x	6x	
6090	PVC 	7B 7C	28000	1x	68500	77000	85500	94000	103000	112000	
7034		7B	733	8x	8x	10x	12x	14x	16x	18x	
7047		4B	M6x48	5x	-	2x	4x	4x	6x	8x	
7052		2, 3 4, 5 6, 7A	M6x12	74x	126x	148x	170x	196x	218x	240x	
7053		1, 2 3, 4 5, 6 7, 8	M6x4	109x	270x	302x	334x	370x	402x	434x	
7054		4B 6	M6x100	2x	12x	12x	12x	14x	14x	14x	
7055		4B 6	M6x10 x14	2x	12x	12x	12x	14x	14x	14x	

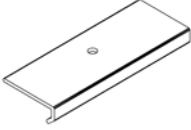

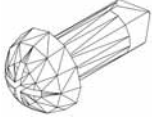
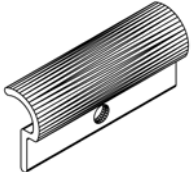

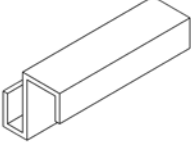

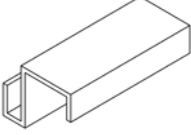
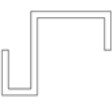

Pack 4 - 1/2					Required Quantity / Model						
Item No.	Part	Section Ref.	Size mm	Quantity in Carton	6200	8100	10000	11900	13800	15700	Profile
7061		1 4A 7A	117	4x	13x	13x	15x	17x	17x	17x	
7062		4	235	3x	5x	6x	7x	8x	9x	10x	
7063		4	255	6x	6x	8x	10x	12x	14x	16x	
7064		1 4A 7A	117	2x	5x	5x	5x	5x	5x	5x	
7080		1 4A 7A	M6x8	16x	52x	52x	60x	68x	68x	68x	
7090		5	324	1x	2x	2x	2x	3x	3x	3x	
7095		1	117	2x	8x	8x	10x	12x	12x	12x	
7244		5	713	1x	2x	2x	2x	3x	3x	3x	
7247 (7291)		5	674	1x	2x	2x	2x	3x	3x	3x	

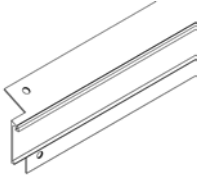
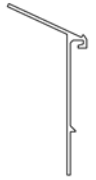
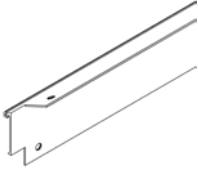
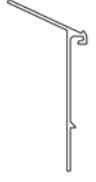
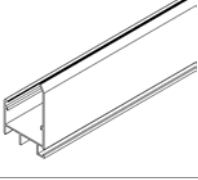

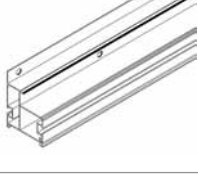

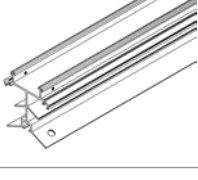

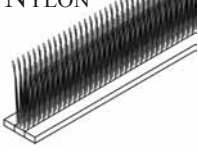

PART LIST, STÜCKLISTE, NOMENCLATURE, ONDERDELENLIJST, STYKLISTE, INNEHÅLL, DELELISTE, OSALUETTELO, ELENCO DEI PEZZI, SEZNAM DÍLŮ, LISTA CZĘŚCI, SEZNAM DELOV, ALKATRÉSZLISTA, POPIS DIJELOVA, LISTA DIJELOVA, LISTA PIESELOR, ZOZNAM ČASTÍ, СПИСОК ДЕТАЛЕЙ, СПИСОК ДЕТАЛЕЙ.

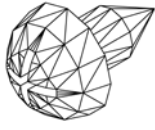
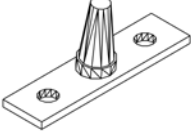
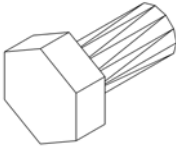
Pack 4 - 1/2					Required Quantity / Model						Profile
Item No.	Part	Section Ref.	Size mm	Quantity in Carton	6200	8100	10000	11900	13800	15700	
7248 (7291)		5	674	1x	2x	2x	2x	3x	3x	3x	
7289		7B 7C	M6x42	35x	126x	136x	146x	156x	166x	176x	
7291 (7247 & 7248)	PVC 	5	674	2x	4x	4x	4x	6x	6x	6x	
7293		5	713	1x	2x	2x	2x	3x	3x	3x	
7294		4B	708	1x	2x	2x	2x	3x	3x	3x	
7296		7A	707	8x	6x	8x	10x	12x	14x	16x	
7297		7A	687	8x	6x	8x	10x	12x	14x	16x	
7298		7A*	30	15x	4x +6x*	6x +8x*	8x +10x*	9x +12x*	11x +14x*	13x +16x*	
7299		7A*	30	15x	4x +6x*	6x +8x*	8x +10x*	9x +12x*	11x +14x*	13x +16x*	

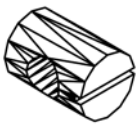



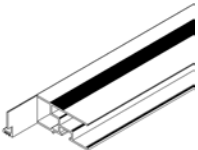

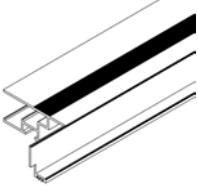

Pack 4 - 1/2					Required Quantity / Model						
Item No.	Part	Section Ref.	Size mm	Quantity in Carton	6200	8100	10000	11900	13800	15700	Profile
7343		7A	56	6x	2x	4x	6x	8x	10x	12x	
7349		7A* 8	3.9x10	46x	40x	52x	64x	76x	88x	100x	
7369		8	30	2x	4x	4x	4x	6x	6x	6x	
7406		7B	30	8x	12x	14x	16x	18x	20x	22x	
7407		7B	30	8x	12x	14x	16x	18x	20x	22x	

**PART LIST, STÜCKLISTE, NOMENCLATURE, ONDERDELENLIJST, STYKLISTE, INNEHÅLL, DELELISTE, OSALUETTELO,
ELENCO DEI PEZZI, SEZNAM DÍLŮ, LISTA CZĘŚCI, SEZNAM DELOV, ALKATRÉSZLISTA,
POPIS DIJELOVA, LISTA DIJELOVA, LISTA PIESELOR, ZOZNAM ČASTÍ, СПИСОК ДЕТАЛЕЙ, СПИСОК ДЕТАЛЕЙ.**

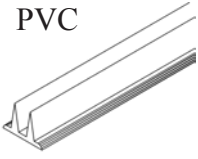
Pack 4 - 2/2					Required Quantity / Model						
Item No.	Part	Section Ref.	Size mm	Quantity in Carton	6200	8100	10000	11900	13800	15700	Profile
7205		2	3027	1x	-	-	-	-	1x	2x	
7206		2	3027	1x	-	-	-	-	1x	2x	
7215		7A	3027	2x	-	-	-	-	2x	4x	
7224		1	3008	2x	-	-	-	-	2x	4x	
7252		4A	3008	1x	-	-	-	-	1x	2x	
7259	NYLON 	4A	3008	2x	-	-	-	-	2x	4x	

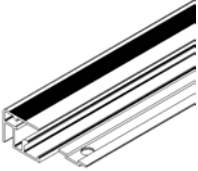
Pack 5 - Roof Vent					Required Quantity / Model						
Item No.	Part	Section Ref.	Size mm	Quantity in Carton	6200	8100	10000	11900	13800	15700	Profile
1006		4B 5 6	3.5x6	6x	30x	30x	30x	36x	36x	36x	
6056		4B	46	2x	4x	4x	4x	6x	6x	6x	
7052		2, 3 4, 5 6, 7A	M6x12	4x	126x	148x	170x	196x	218x	240x	
7053		1, 2 3, 4 5, 6 7, 8	M6x4	4x	270x	302x	334x	370x	402x	434x	
7054		4B 6	M6x100	2x	12x	12x	12x	14x	14x	14x	
7055		4B 6	M6x10 x14	2x	12x	12x	12x	14x	14x	14x	
7090		5	324	1x	2x	2x	2x	3x	3x	3x	
7244		5	713	1x	2x	2x	2x	3x	3x	3x	
7247 (7291)		5	674	1x	2x	2x	2x	3x	3x	3x	

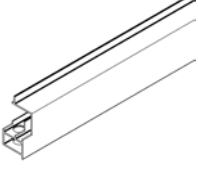
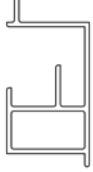
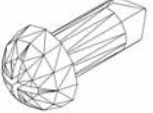
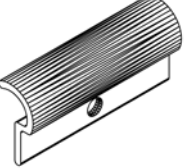
**PART LIST, STÜCKLISTE, NOMENCLATURE, ONDERDELENLIJST, STYKLISTE, INNEHÅLL, DELELISTE, OSALUETTELO,
ELENCO DEI PEZZI, SEZNAM DÍLŮ, LISTA CZĘŚCI, SEZNAM DELOV, ALKATRÉSZLISTA,
POPIS DIJELOVA, LISTA DIJELOVA, LISTA PIESELOR, ZOZNAM ČASTÍ, СПИСОК ДЕТАЛЕЙ, СПИСОК ДЕТАЛЕЙ.**

Pack 5 - Roof Vent					Required Quantity / Model						
Item No.	Part	Section Ref.	Size mm	Quantity in Carton	6200	8100	10000	11900	13800	15700	Profile
7248 (7291)		5	674	1x	2x	2x	2x	3x	3x	3x	
7291 (7247 & 7248)	PVC 	5	674	2x	4x	4x	4x	6x	6x	6x	
7293		5	713	1x	2x	2x	2x	3x	3x	3x	
7294		4B	708	1x	2x	2x	2x	3x	3x	3x	
7349		7A* 8	3.9x10	2x	40x	52x	64x	76x	88x	100x	
7369		8	30	2x	4x	4x	4x	6x	6x	6x	



Dear Customer,

Thank you for choosing our quality product.

We feel confident that it will bring you a lot of pleasure.



Please read these instructions carefully and completely before assembling your greenhouse.

RECOMMENDATIONS

Note: The product you have purchased is intended **only** for the growing of plants and should **only** be used for this purpose. When used for other purposes we will take no responsibility.

Site Selection: Always try to select a sunny location, sheltered from the wind as much as possible. The site selection is important to ensure best results when cultivating your plants and for the safety of your house.

0. Foundation:

The following foundation specifications are suggestions only.

Important: The foundation must extend down below the frost level.

For the erection of this greenhouse we suggest a solid foundation. It is possible to prepare this foundation from concrete, brickwork or stonework. If you have no experience with the construction of such a foundation please consult a company specialising in this work.

Important: The greenhouse should be connected to the foundation only after the greenhouse is completely assembled and it has been checked to be exactly right angular and level.

Before you begin:

Before assembling your new greenhouse, please check that all parts in the provided lists are included. Please take each bundle out of the packaging in order to identify the parts better.

The part lists are sorted according to the carton in which they are delivered.

It is important that the opened bundles do not get mixed with one another.

If something is missing please contact your retailer.

If you find that a part does not fit as shown **do not** make any changes to the part. Please contact your retailer, who will guide you to the relevant customer service partner.

Our policy is one of continuous improvement and we reserve the right to change the specifications without prior notice. This can lead to small differences between your product and that shown in this manual.



Choking Hazard -
Contains small parts

SAFETY NOTICE

- **Sharp edges and corners can cause injury.** Always wear protective glasses, gloves, shoes and headgear when handling the aluminium profiles, glass and polycarbonate sheets. Broken glass is a safety hazard – always clear up immediately and dispose of with care.
- **It is recommended that this greenhouse is assembled by two to three people.**
- **Important! Danger of crushing during assembly.**
- **Do not climb onto the roof surfaces.** There is a danger of falling.
- **The greenhouse should not be assembled during strong wind or storm conditions.**
- **The greenhouse must always be anchored.**
- **Please check the tightness of all nuts and bolts 2 weeks after completing the assembly.** (14)
- **In the event of high wind conditions, close the doors and all vents.**
- **In the event of heavy snowfall, clear the roof of the building or take suitable measures to support the roof. Heat the building in winter.**

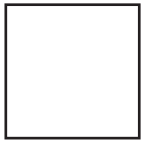

Diagrams in a single frame show the view from inside the greenhouse.



Important Tip, please take note:

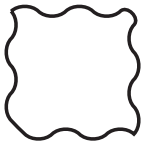

Diagrams in a wavy frame show the view from outside the greenhouse.



Is not included in carton.

MAINTENANCE

The greenhouse should be thoroughly washed with a gentle detergent occasionally. The glass can be cleaned with glass cleaner. Please check that the cleaning agents used do not react aggressively with aluminium or plastic.

If you are unsure if the cleaning agent is appropriate please test it on a small area out of direct sunlight.



Note:

For the complete protection of your new greenhouse, we advise you to include it in your house insurance. Please take note of possible building rules relating to the positioning of greenhouses.

Please stick the included greenhouse model label onto the door bar after successfully assembling this product. This information is important in the event that replacement parts are later required.

Please keep these Assembly Instructions in a safe place, for future reference!



Note:

Please follow exactly the instructions and tips provided in this instruction manual to avoid any difficulties. Should you find a potential failure in this manual, or find a point not clearly explained, please contact your retailer.

We appreciate your suggestions and support.

A full range of greenhouse accessories, to help you make the most of this product, is available from your stockist. Please make yourself aware of these.

Sehr geehrte Kundin, sehr geehrter Kunde,
danke, dass Sie sich für unser Produkt entschieden haben.
Wir sind überzeugt, dass es Ihnen viel Freude bereiten wird.



Bitte lesen Sie diese Aufbauanleitung vor Beginn der Montage komplett durch!

EMPFEHLUNGEN

Hinweis: Das von Ihnen erworbene Produkt ist für die Aufzucht von Pflanzen konstruiert und sollte auch ausschließlich dafür genutzt werden. Bei anderweitiger Nutzung ist jegliche Haftung ausgeschlossen.

Standortwahl: Suchen Sie den sonnigsten, aber gleichzeitig auch einen windgeschützten Platz für Ihr Gewächshaus aus. Die Standortwahl ist extrem wichtig für den Aufzuchterfolg und die Sicherheit Ihres Hauses.

0. Fundament: Angaben zum Fundament sind lediglich Empfehlungen.

Das Fundament muss frostfrei gegründet werden.

Für das Aufstellen des Gewächshauses benötigen Sie einen festen Sockel. Es ist möglich, diesen festen Sockel (das Fundament) aus Beton oder aus Mauerwerk zu fertigen. Sollten Sie über keinerlei Erfahrung mit Fundamentarbeiten verfügen, wenden Sie sich bitte an einen Fachmann.

Erst wenn alles im Winkel und fertig montiert ist, verbinden Sie den Sockel mit dem unteren Bodenrahmen des Hauses.

Bevor Sie beginnen:

Bevor Sie mit der Montage Ihres Gewächshauses beginnen, überprüfen Sie, ob alle in der Liste aufgeführten Teile vorhanden sind. Nehmen Sie die einzelnen Bündel aus der Verpackung, um sie besser identifizieren zu können.

Die Teileliste ist kartonweise gegliedert.

Es ist wichtig, dass die geöffneten Bündel nicht durcheinander geraten.

Sollte trotz sorgfältigster Prüfung etwas fehlen, dann setzen Sie sich bitte mit Ihrem Lieferanten in Verbindung.

Sollte es einmal vorkommen, dass ein Teil vermeintlich nicht passt, fangen Sie nicht an zu bohren oder zu sägen. Kontaktieren Sie Ihren Vertragspartner. Der für Sie zuständige Kundendienst wird sich mit Ihnen in Verbindung setzen.

Weiterentwicklungen im Sinne des technischen Fortschritts behalten wir uns vor. So können geringfügige Abweichungen in den Darstellungen entstehen.



Erstickungsgefahr -
Enthält Kleinteile

SICHERHEITSHINWEISE

- Bei der Handhabung von Glas, Hohlkammerplatten oder Gewächshausteilen sind immer eine Schutzbrille, Handschuhe, Sicherheitsschuhe und ein Kopfschutz zu tragen, da scharfe Kanten zu Verletzungen führen können. Gebrochenes Glas ist ein Sicherheitsrisiko. Beseitigen Sie es bitte mit der gebotenen Vorsicht.
- Es wird empfohlen, dieses Gewächshaus von 2-3 Personen aufbauen zu lassen.
- Achtung! Quetschgefahr bei der Montage.
- Beim Einbau der Verglasung zusätzlich eine Schutzbrille tragen.
- Die Dachflächen dürfen nicht betreten werden. Es besteht Absturzgefahr.
- Montage darf nicht bei starkem Wind oder Sturm erfolgen.
- Nach 2 Wochen bitte alle Schraubverbindungen nachziehen
- Das Gewächshaus muss immer verankert werden.
- Kontrollieren Sie nach 14 Tagen den festen Sitz der Muttern. **14**
- Dächer von Gewächshäusern sind so rechtzeitig von Schnee zu räumen, dass keine gefährliche Schneebelastung eintreten kann. Bei stärkeren Schneefällen muss das Dach schnellstmöglich freigeräumt werden.
- Bei starkem Wind sollten alle Öffnungen (Fenster und Türen) geschlossen werden, da der Wind sonst mehr Angriffsfläche erhält.
- Beheizen Sie das Gewächshaus im Winter.

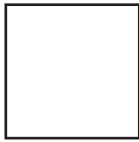

**Abbildungen mit einfachem
Rahmen:
Innenansicht**



**Wichtiger Hinweis,
unbedingt zu beachten**

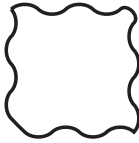

**Abbildungen mit gewelltem
Rahmen:
Aussenansicht**



**Gehört nicht zum
Lieferumfang.**

WARTUNG UND PFLEGE

Das Gewächshaus sollte hin und wieder gründlich mit einem neutralen Reinigungsmittel abgewaschen werden. Das Glas kann mit einem Reinigungsmittel gesäubert werden, das weder Kunststoffteile noch den Aluminiumrahmen angreift.

Sollten Sie unsicher sein, ob das von Ihnen verwendete Mittel verträglich ist, testen Sie es bitte zuerst an einer kleinen, der Sonne abgewandten Stelle.

Hinweis:



Zum vollen Schutz des Gewächshauses und zur generellen Vorbeugung empfehlen wir, das Gewächshaus mit in Ihre Hausrat- oder Gebäudeversicherung einzubeziehen. Wenden Sie sich zu diesem Zwecke an Ihren Versicherer.

Informieren Sie sich über evtl. vorhandene örtliche Bauvorschriften.

Bitte kleben Sie den beiliegenden Typenaufkleber nach dem Aufbau auf das Türprofil. Diese Modellbezeichnung ist wichtig, falls Sie später einmal Ersatzteile brauchen sollten. Bewahren Sie die Montageanleitung gut auf!



Folgen Sie genau den Angaben und Hinweisen dieser Bedienungsanleitung und Sie werden bei der Montage keine Schwierigkeiten haben. Sollten Ihnen vermeintliche Fehler in der Bedienungsanleitung auffallen oder ist Ihnen ein Passus unklar, wenden Sie sich bitte an Ihren Händler oder schreiben Sie uns an folgende e-Mail-Adresse:

kundendienst@eph-schmidt.de

Wir sind für Ihre Anregungen und Unterstützung dankbar.

Chère cliente, cher client,
 Merci d'avoir choisi notre produit.
 Nous sommes convaincus qu'il vous procurera une grande satisfaction.



Merci de lire ces instructions intégralement avant de commencer le montage !

RECOMMANDATIONS

Remarque: Le produit que vous venez d'acquérir a été conçu pour la culture de plantes et doit être utilisé exclusivement dans cet objectif. Nous excluons toute responsabilité en cas d'autre utilisation.

Choix de l'emplacement: Choisissez l'emplacement le plus ensoleillé mais aussi le mieux protégé du vent pour votre serre. Le choix de l'emplacement est extrêmement important pour la réussite de vos cultures et la sécurité de votre serre.

0. Fondation: Les indications sur les fondations ne sont que des recommandations.

Les fondations doivent être à l'abri du gel.

Vous avez besoin d'une embase solide pour installer la serre. Il est possible de réaliser cette embase (ces fondations) en béton ou en maçonnerie. Si vous n'avez aucune expérience dans le domaine de travaux de fondation, merci de vous adresser à un spécialiste.

Ce n'est que quand tout est entièrement monté et perpendiculaire que vous pourrez fixer le cadre du plancher de la cabane avec l'embase.

Avant de commencer: Avant de commencer le montage de votre serre, vérifiez que vous disposez de toutes les pièces telles qu'elles sont indiquées dans la liste. Retirez les différents paquets de l'emballage pour mieux les identifier.

La liste des pièces est triée par carton.

Il est important de ne pas mélanger les paquets ouverts.

Si, malgré nos contrôles attentifs, un élément devait manquer, merci de contacter votre fournisseur.

S'il devait arriver qu'une pièce ne soit éventuellement pas adaptée, ne commencer pas à percer ni à scier. Contactez votre partenaire de contrat. Le service après-vente compétent vous contactera.

Sous réserve de développements effectués dans l'objectif du progrès technologique. Il est donc possible que les représentations présentent de légères divergences.



Risque d'étouffement -
 Contient de petites
 pièces

CONSIGNES DE SÉCURITÉ

- **Toujours porter des lunettes et des gants de protection, des chaussures de sécurité et un casque lors de la manipulation du verre, des panneaux alvéolaires ou des éléments de la serre étant donné que les rebords coupants peuvent sinon provoquer des blessures. Le verre brisé constitue un risque. Merci de l'éliminer avec la prudence qui s'impose.**
- **Il est recommandé de faire monter cette serre par 2 ou 3 personnes.**
- **Attention ! Risques d'écrasement lors du montage.**
- **Porter en plus des lunettes de protection lors de l'installation du vitrage.**
- **Ne montez pas sur les surfaces du toit. Il y a un risque de chute.**
- **Le montage ne doit pas être effectué en cas de vent fort ou de tempête.**
- **Merci de resserrer tous les raccords vissés après 2 semaines.**
- **La serre doit toujours être ancrée.**
- **Contrôlez tous les 14 jours que les écrous sont toujours bien serrés.** 
- **Les toits des serres doivent être rangés à temps avant la chute de neige de manière à éviter toute charge dangereuse due à la neige. En cas de chutes de neige importantes, le toit doit être retiré aussi vite que possible.**
- **En cas de vents forts, toutes les ouvertures (fenêtres et portes) doivent être fermées sinon le vent dispose de davantage de surface de prise.**
- **Chauffez la serre pendant l'hiver.**



Illustration avec cadre simple :
vue intérieure

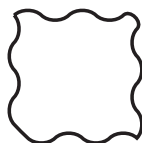

Illustration avec cadre ondulé :
vue extérieure



Remarque importante
À observer impérativement

N'est pas comprise dans la livraison.

MAINTENANCE ET ENTRETIEN

La serre doit être nettoyée de temps en temps avec un produit nettoyant neutre. Les vitres peuvent être nettoyées avec un produit qui n'attaque ni les pièces en plastique ni le cadre en aluminium.

Si vous n'êtes pas sûr que le produit que vous utilisez soit adapté, effectuez tout d'abord un essai sur une petite surface protégée du soleil.



Remarque :

Pour protéger au maximum votre serre et par prévention générale, nous recommandons de l'inclure dans votre couverture d'assurance ménagère et immobilière. Pour cela, merci de vous adresser à votre assureur.

Renseignez-vous sur les éventuelles réglementations de construction locales.

Merci de coller la plaque signalétique ci-jointe sur le profilé de la porte après le montage. La désignation du modèle est importante pour le cas où vous auriez besoin plus tard d'une pièce de rechange. Conservez ces instructions de montage soigneusement !



Remarque :

Suivez fidèlement les instructions et les indications de cette notice d'utilisation et vous n'aurez aucun problème à effectuer le montage. Si vous deviez constater d'éventuelles erreurs dans cette notice ou si un passage vous semble peu clair, veuillez contacter votre revendeur.

Merci pour vos critiques et votre soutien.

Beste klant,

Hartelijk dank voor het kiezen van ons kwaliteitsproduct.
Wij vertrouwen erop dat het u veel plezier zal opleveren.



Leest u eerst de gehele instructies door alvorens te beginnen met de opbouw van de kas.

ADVIEZEN

N.B.: Het product dat u hebt gekocht, is **uitsluitend** bestemd voor het kweken van planten en dient **uitsluitend** voor dit doel te worden gebruikt. Wanneer het voor andere doeleinden zal worden gebruikt, dragen wij hier geen verantwoordelijkheid voor.

Kiezen plaats: Probeer altijd een zonnige plaats te kiezen die zoveel mogelijk tegen wind beschermt is. De keuze van de plaats is belangrijk om de beste resultaten te behalen bij het kweken van uw planten en voor de veiligheid van uw kas.

0. Fundering: De volgende funderingsspecificaties zijn alleen maar suggesties.

Belangrijk: De fundering moet tot beneden de vorstgrens zitten.

Wij adviseren een vaste fundering om deze kas op te zetten. Deze fundering kan worden voorbereid met beton, metsel- of steenwerk. Als u geen ervaring hebt met het maken van een dergelijke fundering, moet u een bedrijf raadplegen dat zich in dit werk specialiseert.

Belangrijk: De kas dient pas op de fundering te worden gemonteerd nadat de kas volledig is gemonteerd en gecontroleerd is of zij haaks en waterpas staat.

Voordat u begint: Controleer a.u.b. of u alle onderdelen op de meegeleverde lijst hebt voordat u begint aan het in elkaar zetten van uw nieuwe kas. Haal a.u.b. elk pakket uit de doos om de onderdelen beter te identificeren.

De onderdelenlijsten zijn gesorteerd volgens de doos waarin zij worden geleverd.

Het is belangrijk dat de open pakketten niet door elkaar gehaald worden.

Als er onderdelen ontbreken, neem dan a.u.b. contact op met uw leverancier.

Als u merkt dat een onderdeel niet past zoals op de tekening, breng dan **geen** veranderingen aan het onderdeel aan. Neem a.u.b. contact op met uw leverancier, die u naar de relevante klantenservicepartner zal doorverwijzen.

Ons beleid is gebaseerd op het continu verbeteren van onze producten en hierdoor behouden wij ons het recht voor om modellen te veranderen zonder verdere berichtgeving. Dit kan ertoe leiden dat er kleine verschillen zijn tussen uw product en het product dat in deze handleiding staat.



Verstikking -

0-3 Bevat kleine onderdelen

VEILIGHEIDSREGELS

- Scherpe hoekjes en randen kunnen tot verwondingen leiden. Draag altijd een veiligheidsbril, beschermende handschoenen, schoenen en hoofdbedekking als u werkt met de aluminium profielen, glas- en polycarbonaat platen. Gebroken glas is een veiligheidsrisico - u dient het veilig en meteen op te ruimen.
- Wij raden u aan de kas met twee tot drie personen in elkaar te zetten.
- **Belangrijk!** Gevaar voor platdrukken tijdens de montage.
- Klim niet op de dakvlakken. Er bestaat gevaar voor vallen.
- De kas moet **niet** tijdens harde wind of storm worden gemonteerd.
- De kas moet **altijd** worden verankerd.
- Controleer a.u.b. twee weken na het voltooien van de montage of alle moertjes en boutjes vastzitten. 
- Sluit bij zware wind altijd de deuren en alle ramen.
Houd bij zware sneeuwval het dak van de kas vrij of zorg voor een goede ondersteuning van het dak. Verwarm de kas in de winter.

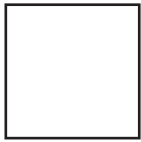

Op de tekeningen met het enkelvoudige frame wordt de binnenkant van de kas getoond.



Belangrijke tip, in acht nemen a.u.b.:

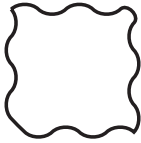

Op de tekeningen met het golvend frame wordt de buitenkant van de kas getoond.



Deze is niet inbegrepen.

ONDERHOUD

Om uw kas schoon te houden dient deze af toe grondig gereinigd te worden met een zacht reinigingsmiddel. Het glas kan met een glasreinigingsmiddel worden gereinigd. Zorg er a.u.b. voor dat de reinigingsmiddelen niet agressief reageren met aluminium of kunststof.

Als u niet zeker weet of het reinigingsmiddel toepasselijk is, test het dan a.u.b. op een klein stuk dat niet in de volle zon ligt.



N.B.:

Voor de gehele bescherming van uw nieuwe kas raden wij u aan om deze op te nemen in uw opstalverzekering. Denk er ook aan dat de kas aan alle bouweisen moet voldoen en houd ook rekening met de plaats van de kas.

Plak alstublieft de inbegrepen sticker van het kasmodel op het deurprofiel nadat de kas succesvol is geïnstalleerd. Deze informatie is belangrijk voor het vervangen van onderdelen in de toekomst.

Bewaar de instructies op een veilige plek zodat u deze nog altijd kunt nalezen!



N.B.:

Volg a.u.b. de instructies en tips in deze instructiehandleiding exact op om moeilijkheden te voorkomen. Mocht u een potentiële fout in deze handleiding aantreffen, of een punt dat niet duidelijk uitgelegd is, neem dan a.u.b. contact op met uw leverancier.

Wij stellen uw suggesties en steun op prijs.

Er is een compleet assortiment kasaccessoires beschikbaar bij uw leverancier om dit product ten volle te benutten. Neem hier nota van a.u.b.

Kære kunde,

Tak fordi De har valgt et Vitavia produkt. Vi er overbevist om, at De vil få megen glæde af og mange gode stunder i Deres drivhus.



Læs venligst hele denne monteringsvejledning, inden samling og opstilling af drivhuset påbegyndes.

ANBEFALINGER

Bemærk venligst! Dette produkt er konstrueret som et drivhus beregnet til planteavl og er som sådan ikke konstrueret til at være helt tæt, da det er nødvendigt med udluftning bl.a. for at undgå kondensdannelse.

Såfremt De ønsker at anvende drivhuset som et ”uderum/stue” eller lignende, gør vi udtrykkeligt opmærksom på, at drivhuset ikke er 100 % vandtæt, og at vi ikke påtager os noget ansvar for eventuelle skader på løsøre el. lign., der er anbragt i drivhuset.

Til montage af dette produkt kræves min. 2 personer.

Skulle De få problemer med drivhusmontagen eller glasisætning, bedes De kontakte Deres forhandler eller vor kundeservice på opj@opj.dk

Anvend ikke vold.

Placering: Vælg et solrigt sted, hvor der er mest muligt læ. Undgå at placere drivhuset på steder, hvor der kan opstå turbulens pga. nærtstående bygninger.

0. Fundament / Sokkel: Oplysninger vedr. fundamentet er at betragte som vejledende forslag.

Drivhuset skal opstilles på et stabilt fundament / sokkel. Soklen kan laves f.eks. som en fuldstøbt betonsokkel eller bygges op i mursten eller Leca-sten.

Soklen skal gå ned i frostfri dybde (80-90 cm) for at undgå skævvridninger.

Bundrammen skal først fastgøres til fundamentet, når hele drivhuset er færdigmonteret, og alt er i vater, lod og vinkel.

Vigtigt: Før De begynder at samle Deres drivhus, kontroller venligst efter indholdsfortegnelsen, at alle dele er medleveret. Tag de enkelte bundter ud af kassen for bedre at kunne kontrollere indholdet. Undgå så vidt muligt at åbne delpakkerne, før De når til det pågældende punkt i vejledningen.

Numrene på bundterne stemmer overens med nummereringen i monteringsvejledningen.

Det er vigtigt ikke at blande åbnede bundter.

Hvis der mangler noget, kontakt venligst Deres forhandler.

Såfremt De mener, at en del ikke passer, må De under ingen omstændigheder begynde at tilpasse denne del ved at bore eller save i aluminiumsprofilerne. Kontakt i stedet vor kundeservice på opj@opj.dk, der vil hjælpe Dem videre.

Vi forbeholder os ret til at foretage tekniske ændringer af produktet og dets specifikationer, hvilket kan medføre ændringer i vejledningerne.

På vor hjemmeside vil De altid kunne finde den nyeste udgave af monteringsvejledningen. Såfremt denne måtte afvige væsentligt fra Deres produkt, er De velkommen til at kontakte vor kundeservice på opj@opj.dk. De kan identificere Deres udgave af vejledningen ved hjælp af det nummer, der er anført nederst på alle sider i vejledningen.



Kvælningsfare -
Indeholder små dele

SIKKERHEDSHENVISNINGER

- De bør altid bruge handsker, når De arbejder med polycarbonatplader eller glas. Skarpe kanter kan forårsage skader. Der kan også forekomme skarpe kanter på kanter og hjørner på aluminiumsprofiler. Her bør De også bære handsker. Ved isætning af glas bør De også anvende beskyttelsesbriller, sikkerhedssko og hovedbeskyttelse (sikkerhedshjelm). Itugået glas udgør en sikkerhedsrisiko og bør bort-skaffes med forsigtighed.
- NB! Udvis forsigtighed ved glasmontage. Glasset kan splintre under monteringen.
- Bær gerne sikkerhedsbriller, medens glasset monteres.
- Du må ikke klatre op på tagfladerne. Der er fare for at falde ned.
- Samling af drivhuset og montering af glas bør ikke foretages i stærk blæst eller storm.
- Efter ca. 2 uger efterspændes alle bolte uden at overspænde disse. **14**

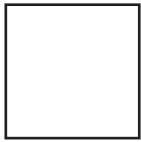

Tegninger med enkeltramme er set indefra.



NB!: Vigtigt tip! Bemærk venligst!

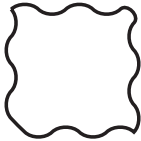

Tegninger med bølget ramme er set udefra.



Indgår ikke i leverancen.



VEDLIGEHOJDELSE

Drivhuset bør lejlighedsvis rengøres grundigt med et mildt rengøringsmiddel. Glasset kan rengøres med et hvilket som helst rengøringsmiddel, der ikke skader aluminiumsprofiler eller glasholdere og clips, f. eks. Vitavia drivhusrens eller brun sæbe. Test eventuelt på et mindre område, hvis De er i tvivl.

Dørskinnerne bør regelmæssigt rengøres og smøres med stearin/grafitolie.

Ved snefald fjernes sneen fra taget, således at der ikke opstår risiko for skader som følge af snebelastningen af glas og profiler. Ved kraftigt snefald og ved skiftevis tød- og frostvejr skal sne fjernes hurtigst muligt fra taget.

Ved risiko for kraftigt snefald understøttes tagryggen med en stolpe eller lign.

Ved kraftig blæst skal alle vinduer og døre lukkes. Afmonter / deaktiver eventuelle automatiske vinduesåbnere.



ANMÆRKNING

Vi anbefaler, at De sørger for, at Deres husforsikring også dækker Deres drivhus. Overhold alle byggevedtægter. Kontakt Teknisk Forvaltning i Deres kommune, hvis De er i tvivl.

Typebetegnelsen skal De bruge ved bestilling af evt. reservedele, så opbevar venligst montagevejledningen til senere brug.

Skulle De få problemer med drivhusmontagen eller glasisætning, bedes De kontakte Deres forhandler eller vor kundeservice på opj@opj.dk

Følg de beskrevne arbejdsgange meget omhyggeligt. Såfremt De mener, at der skulle være fejl ved produktet eller i vejledningen, eller hvis noget er uklart, er De velkommen til at kontakte os på opj@opj.dk Vi forsøger løbende at opdatere vore vej-ledninger og modtager gerne input via e-mail.

Kära kund,

Tack för att ni valt en Vitavia produkt. Vi är övertygade om att du kommer få mycket glädje av ditt växthus.



Vänligen läs igenom hela monteringsanvisningen innan ni påbörjar monteringen av växthuset.

FÖRSLAG

Notera följande! Du har köpt ett växthus, som är konstruerat för odling av planter och bör uteslutande användas för detta ändamål. Vid annan användning bortfaller producentens ansvar och garantier.

För montering av detta växthus krävs minst 2 personer.

Skulle du få problem med monteringen eller glasmonteringen ombedes du kontakta din återförsäljare.

Använd inte våld.

Placering: Välj en solig plats, med mesta möjliga lä. Undvik att placera växthuset på platser där det kan uppstå turbulent vind pga närliggande byggnader.

0. Fundament / sockel: Upplysningar om fundamentet betraktas som vägledande förslag.

Växthuset skall monteras på ett stabilt fundament/sockel. Sockeln kan tillverkas som tex en helgjuten betongsockel eller byggas i betongsuggor eller leca sten.

Sockeln skall fästas på frostfritt djup (80-90 cm) för att undvika sättningar.

Bottenramen skall fästas på fundamentet först när hela växthuset är färdigmonterat och allt är i lod, vågrätt och vinkelrätt.

Viktigt :Innan du börjar montera växthuset, kontrollera att alla delarna är levererade med hjälp av innehållsförteckningen. Tag ut de numrerade buntarna ur kartongerna, men undvik att öppna dem innan du kommit till den punkten i monteringen.

Numren på buntarna stämmer överens med numreringen i monteringsanvisningen.

Det är viktigt att inte blanda öppnade buntar.

Om något saknas, kontakta din återförsäljare.

Om du anser att en del inte passar, får du under inga omständigheter börja borra eller såga i aluminiumprofilen för att få den att passa. Kontakta istället din återförsäljare för hjälp.

Vi förbehåller oss rätten att göra tekniska förändringar av produkten och dess specifikationer, vilket kan föranleda förändringar i monteringsanvisningen.

På vår hemsida finns alltid den nyaste utgåvan av monteringsanvisningen. Skulle måtten avvika väsentligt från din produkt kan du kontakta din återförsäljare så kan de hjälpa till att identifiera er variant med hjälp av info som finns i din monteringsanvisning.



Kvävningsrisk -
Innehåller små delar

SÄKERHETSANVISNINGAR

- **Du bör alltid använda handskar, när du arbetar med polycarbonatskivor eller glas. Vassa kanter kan förorsaka skador. Det kan också förekomma vassa kanter på hörn på aluminiumprofilerna. Vid isättning av glas bör du också använda skyddsglasögon, skyddsskor och skydd för huvudet (säkerhetsk hjälm). Krossat glas utgör en säkerhetsrisk och bör föras undas med försiktighet.**
- **Obs! Vidtag försiktighet vid glasmontage. Glaset kan gå sönder under monteringen.**
- **Bär gärna skyddsglasögon, medan glaset monteras.**
- **Klättra inte upp på takytorna. Det finns risk för fall.**
- **Montering av växthuset och montering av glas bör inte göras i kraftig blåst eller storm.**
- **Efter ca. 2 veckor bör alla bultar efterdras utan att överdras.**

14

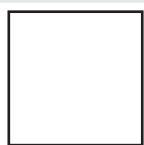

Ritningar med enkel ram är huset sett inifrån.



OBS!: Viktigt tips!
Notera!

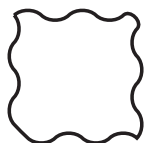

Ritningar med vågig ram är huset sett utifrån.



Ingår inte i leveransen.



UNDERHÅLL

Växthuset bör regelbundet rengöras grundligt med ett mildt rengöringsmedel. Glaset kan rengöras med vilket rengöringsmedel som helst som inte skadar aluminiumprofilerna, glashållare eller clips etc. Vitavia växthusrengöring eller gul såpa tex. Testa gärna ditt medel på ett mindre område om du är osäker.

Dörrskenor bör regelbundet rengöras och smörjas med parrafin eller grafitolja.

Vid snöfall skall snön tas bort från taket så att sakor ej uppstår pga för stor tyngd på glas och profiler. Vid kraftigt snöfall och vid emperaturskiftningar skall snön tas bort från taket så snart som möjligt.

Vid risk för kraftigt snöfall kan takstolen stöttas med en stolpe eller liknande.

Vid kraftigt blåst skall alla fönster och dörrar reglas. Avmontera / deaktivera eventuella automatiska fönsteröppnare.



ANMÄRKNING

Vi föreslår att hemförsäkringen även täcker ert växthus. Följ alla byggnadsregler. Kontakta byggnadsnämnen i er kommun om du är osäker.

Typbeteckningen du skall använda vid eventuell efterbeställning av reservdelar finns i monteringsanvisningen, så bevara denna även efter monteringen.

Skulle du få problem med monteringen kontakt din återförsäljare.

Följ den beskrivna arbetsgången så mycket som möjligt. Skulle du anse det vara fel på produkten eller monteringsanvisningen så är du välkommen att kontakta opj@opj.dk Vi försöker att löpande uppdatera våra anvisningar och mottager gärna input via e-mejl.

Kjære kunde,
Takk for at du valgte vårt kvalitetsprodukt.
Vi er sikre på at det vil gi deg mye glede.



Les disse instruksjonene nøye og fullstendig før du monterer drivhuset.

ANBEFALINGER

Merk: Produktet du har kjøpt, er **kun** beregnet for dyrking av planter og skal **kun** brukes til dette formålet. Ved bruk til andre formål påtar vi oss intet ansvar.

Valg av sted: Prøv alltid å velge en solrik plassering, mest mulig skjermet for vind. Valg av sted er viktig for å sikre best mulig resultat ved dyrking av plantene og for husets sikkerhet.

0. Stiftelsen: Følgende fundamentspesifikasjoner er kun forslag.

Viktig: Fundamentet må strekke seg ned under frostnivået.

For oppføring av dette drivhuset foreslår vi et solid fundament. Det er mulig å lage dette fundamentet av betong, murverk eller stein. Hvis du ikke har erfaring med å bygge et slikt fundament, kan du kontakte et firma som spesialiserer seg på dette arbeidet.

Viktig: Drivhuset skal først kobles til fundamentet etter at drivhuset er ferdig montert og det er kontrollert at det er nøyaktig rettvisklet og i vater.

Før du begynner:

Før du monterer ditt nye drivhus, må du kontrollere at alle delene i listene som følger med, er inkludert. Ta hver pakke ut av emballasjen for å kunne identifisere delene bedre.

Stykklistene er sortert etter hvilken kartong de leveres i.

Det er viktig at de åpnete pakkene **ikke** blandes med hverandre.

Hvis noe mangler, vennligst kontakt forhandleren din.

Hvis du oppdager at en del ikke passer som vist, må du ikke gjøre noen endringer på delen. Ta kontakt med forhandleren din, som vil veilede deg til den relevante kundeservicepartneren.

Vi arbeider kontinuerlig med forbedringer, og vi forbeholder oss retten til å endre spesifikasjonene uten forvarsel. Dette kan føre til små forskjeller mellom produktet ditt og det som vises i denne håndboken.



Kvelningsfare
- Inneholder små
deler

SIKKERHETSMELDING

- **Skarpe kanter og hjørner kan forårsake personskader. Bruk alltid vernebriller, hansker, sko og hodeplagg når du håndterer aluminiumsprofiler, glass og polykarbonatplater. Knust glass er en sikkerhetsrisiko - rydd alltid opp umiddelbart og kast det med forsiktighet.**
- **Det anbefales at to til tre personer monterer dette drivhuset.**
- **Viktig! Fare for knusing under montering.**
- **Ikke klatre opp på takflatene. Det er fare for å falle ned.**
- **Drivhuset skal ikke monteres under sterk vind eller storm.**
- **Drivhuset må alltid være forankret.**
- **Kontroller at alle muttere og bolter er strammet til 2 uker etter at monteringen er fullført.**
- **Lukk dørene og alle ventilasjonsåpninger i tilfelle kraftig vind.**
- **Ved kraftig snøfall må du rydde taket på bygningen eller iverksette egnede tiltak for å støtte taket. Varm opp bygningen om vinteren.**

14

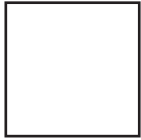

Diagrammer i en enkelt ramme viser utsikten fra innsiden av drivhuset.

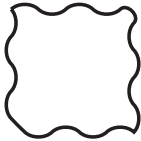

Diagrammer i en bølget ramme viser utsikten fra utsiden av drivhuset.



Viktig tips, vennligst merke til det:



Er ikke inkludert i kartongen.

VEDLIKEHOLD

Drivhuset bør vaskes grundig med et skånsomt vaskemiddel av og til. Glasset kan rengjøres med glassrengjøringsmiddel. Kontroller at rengjøringsmidlene som brukes, ikke reagerer aggressivt med aluminium eller plast.

Hvis du er usikker på om rengjøringsmidlet er egnet, kan du teste det på et lite område utenfor direkte sollys.



Merk:

For å beskytte det nye drivhuset ditt fullt ut, anbefaler vi at du inkluderer det i husforsikringen din. Vær oppmerksom på eventuelle bygningsregler som gjelder plassering av drivhus.

Etter at du har montert dette produktet, må du feste den medfølgende drivhusmodelletiketten på dørstangen. Denne informasjonen er viktig i tilfelle det senere skulle bli behov for reservedeler.

Vennligst oppbevar denne monteringsanvisningen på et trygt sted for fremtidig bruk!



Merk:

Følg instruksjonene og tipsene i denne bruksanvisningen nøye for å unngå problemer. Skulle du finne en potensiell feil i denne bruksanvisningen, eller finne et punkt som ikke er tydelig forklart, ber vi deg kontakte forhandleren din.

Vi setter pris på dine forslag og din støtte.

Et komplett utvalg av drivhustilbehør, som hjelper deg med å få mest mulig ut av dette produktet, er tilgjengelig fra din forhandler. Vennligst gjør deg oppmerksom på disse.

Hyvä asiakas,
Kiitos, että valitsit laatutuottemme.
Olemme varmoja, että se tuottaa sinulle paljon iloa.



Lue nämä ohjeet huolellisesti ja kokonaan ennen kasvihuoneen kokoamista.

SUOSITUKSET

Huomautus: Ostamasi tuote on tarkoitettu **vain** kasvien kasvattamiseen, ja sitä saa **käyttää vain** tähän tarkoitukseen. Jos sitä käytetään muihin tarkoituksiin, emme ota siitä vastuuta.

Sijoituspaikan valinta: Yritä aina valita aurinkoinen paikka, joka on mahdollisimman hyvin tuulelta suojassa. Paikan valinta on tärkeää, jotta voit varmistaa parhaat tulokset kasvien kasvatuksessa ja talosi turvallisuuden kannalta.

0. Säätö: Seuraavat perustuksia koskevat tiedot ovat vain ehdotuksia.

Tärkeää: Perustuksen on ulotuttava pakkasrajan alapuolelle.

Tämän kasvihuoneen pystyttämistä varten suosittelemme vankkaa perustusta. Tämä perustus on mahdollista valmistaa betonista, tiilestä tai kivimuurista. Jos sinulla ei ole kokemusta tällaisen perustuksen rakentamisesta, ota yhteyttä tähän työhön erikoistuneeseen yritykseen.

Tärkeää: Kasvihuone saa liittää perustukseen vasta, kun kasvihuone on koottu kokonaan ja sen kulma ja taso on tarkistettu.

Ennen kuin aloitat:

Tarkista ennen uuden kasvihuoneesi kokoamista, että kaikki mukana toimitetuissa luetteloissa olevat osat ovat mukana. Ota jokainen nippu pois pakkauksesta, jotta osat voidaan tunnistaa paremmin.

Osaluettelot on lajiteltu sen mukaan, missä laatikossa ne toimitetaan.

On tärkeää, etteivät avatut niput sekoitu keskenään.

Jos jotain puuttuu, ota yhteyttä jälleenmyyjään.

Jos huomaat, että osa ei sovi kuvassa esitetyllä tavalla, **älä** tee siihen mitään muutoksia. Ota yhteyttä jälleenmyyjään, joka ohjaa sinut asiaankuuluvan asiakaspalvelukumppanin luo.

Politiikkamme perustuu jatkuvaan parantamiseen, ja pidätämme oikeuden muuttaa eritelmiä ilman ennakoilmoitusta. Tämä voi aiheuttaa pieniä eroja tuotteesi ja tässä käyttöohjeessa esitetyn tuotteen välillä.



Tukehtumisvaara
- Sisältää pieniä osia

TURVALLISUUSILMOITUS

- Terävät reunat ja kulmat voivat aiheuttaa vammoja. Käytä aina suojalaseja, käsineitä, kenkiä ja päähineitä, kun käsittelet alumiiniprofiileja, lasia ja polykarbonaattilevyjä. Rikkinäinen lasi on turvallisuusriski - siivoa se aina välittömästi ja hävitä se huolellisesti.
- On suositeltavaa, että tämän kasvihuoneen kokoamiseen osallistuu kahdesta kolmeen henkilöä.
- Tärkeää! Puristumisvaara kokoonpanon aikana.
- Älä kiipeä kattopinnoille. Siellä on putoamisvaara.
- Kasvihuonetta ei saa koota voimakkaan tuulen tai myrskyn aikana.
- Kasvihuone on aina ankkuroitava.
- Tarkista kaikkien muttereiden ja pulttien kireys 2 viikon kuluttua kokoonpanon valmistumisesta.
- Jos tuuli on kovaa, sulje ovet ja kaikki tuuletusaukot.
- Jos lunta sataa paljon, tyhjennä rakennuksen katto tai ryhdy asianmukaisiin toimenpiteisiin katon tukemiseksi. Lämmitä rakennus talvella.

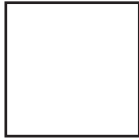

Yhdessä kehyksessä olevat kaaviot näyttävät näkymän kasvihuoneen sisältä.



Tärkeä vinkki, ota huomioon

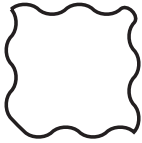

Aaltoilevassa kehyksessä olevat kaaviot näyttävät näkymän kasvihuoneen ulkopuolelta.



Ei sisälly kartonkiin.

HUOLTO

Kasvihuone on pestävä perusteellisesti hellävaraisella pesuaineella silloin tällöin. Lasi voidaan puhdistaa lasinpuhdistusaineella. Tarkista, että käytetyt puhdistusaineet eivät reagoi aggressiivisesti alumiinin tai muovin kanssa.

Jos olet epävarma siitä, onko puhdistusaine sopiva, testaa sitä pienellä alueella, joka ei ole suorassa auringonvalossa.



Huom:

Jotta uusi kasvihuoneesi olisi täysin suojattu, suosittelemme, että otat sen mukaan kotivakuutukseesi. Ota huomioon mahdolliset kasvihuoneiden sijoittamista koskevat rakennusmääräykset.

Kiinnitä mukana toimitettu kasvihuoneen mallitarra ovipalkkiin, kun olet onnistuneesti koonnut tämän tuotteen. Tämä tieto on tärkeä siinä tapauksessa, että myöhemmin tarvitaan varaosia.

Säilytä nämä asennusohjeet turvallisessa paikassa myöhempää käyttöä varten!



Huom:

Noudata tarkasti tässä käyttöohjeessa annettuja ohjeita ja vinkkejä, jotta vältät mahdolliset ongelmat. Jos havaitset tässä käyttöohjeessa mahdollisen vian tai löydät kohdan, jota ei ole selkeästi selitetty, ota yhteyttä jälleenmyyjään.

Arvostamme ehdotuksianne ja tukeanne.

Täydellinen valikoima kasvihuonetarvikkeita, joiden avulla voit hyödyntää tätä tuotetta parhaalla mahdollisella tavalla, on saatavana jälleenmyyjältäsi. Ole hyvä ja tutustu niihin.

Gentile cliente,
 grazie per aver deciso di acquistare il nostro prodotto.
 Siamo certi che ne sarà soddisfatto.



Leggere completamente le presenti istruzioni prima di iniziare i lavori di montaggio!

RACCOMANDAZIONI

Nota: Il prodotto acquistato è ideato per la coltivazione di piante e deve essere utilizzato esclusivamente per questo scopo. Per qualsiasi altro utilizzo si declina ogni responsabilità.

Scelta del luogo: Scegliere possibilmente un posto soleggiato, ma al contempo protetto dal vento. La scelta del posto di installazione è estremamente importante per il successo costruttivo e la sicurezza della serra.

0. Fondamenta: Le indicazioni sulle fondamenta sono solo dei suggerimenti.

Il fondamento deve essere trattato con una mano di antiruggine.

L'installazione della serra richiede un basamento solito. È possibile realizzare questo basamento (fondamenta) in calcestruzzo oppure in muratura. Se non si dovesse avere alcuna esperienza in questo campo, rivolgersi a uno specialista.

Collegare il basamento al telaio inferiore del pavimento della serra solo quando la costruzione sarà ultimata e posta ad angolo retto.

Prima di iniziare i lavori: Prima di iniziare l'operazione di montaggio della serra, accertarsi che siano presenti tutti i componenti elencati. Prelevare i componenti dall'imbballaggio, per poterli identificare meglio.

L'elenco dei pezzi è suddiviso in scatole

È particolarmente importante non mischiare tra di loro i componenti aperti.

Se nonostante un accurato controllo dovessero mancare delle parti, contattate il vostro rivenditore.

Se una delle parti non dovesse combaciare, non iniziare a trapanare o a segare. Contattate il vostro rivenditore. In questo caso il servizio di assistenza vi contatterà a breve.

Ci riserviamo il diritto di applicare modifiche tecniche rivolte allo sviluppo del prodotto. Ciò potrebbe differire dalle rappresentazioni.



Rischio di
 soffocamento -
 Contiene piccole parti

INFORMAZIONI DI SICUREZZA

- **Durante il maneggio di vetro, pannelli di polycarbonato o componenti di serre si raccomanda di portare sempre occhiali di protezione, guanti e calzature di sicurezza nonché un elmetto protettivo, poiché gli spigoli taglienti possono causare delle lesioni. I vetri rotti costituiscono un elevato rischio per la sicurezza. Eliminare i vetri rotti con la massima prudenza.**
- **Si consiglia di far montare la serra da 2-3 persone.**
- **Attenzione! Pericolo di schiacciamento durante il montaggio.**
- **Portare gli occhiali protettivi durante l'installazione della vetratura.**
- **Non salire sulle superfici del tetto. C'è il rischio di cadere.**
- **Non eseguire il montaggio in caso di forte vento o tempesta.**
- **Stringere tutti i collegamenti a vite dopo 2 settimane.**
- **La serra deve essere sempre ancorata al suolo.**
- **Controllare ogni 14 giorni che i dadi siano stretti a fondo.** 
- **Eliminare tempestivamente la neve dai tetti delle serre in modo da evitare qualsiasi carico di neve pericoloso. In caso di forti nevicate, togliere subito il tetto dalla neve.**
- **In presenza di forte vento, tenere chiuse tutte le aperture (finestre porte), poiché in questo caso il vento avrebbe una maggiore superficie di attacco.**
- **Riscaldare la serra in inverno.**

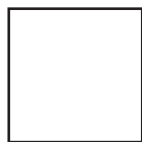

**Figure con telai a una struttura:
Vista interna**



**Importante indicazione
Osservare assolutamente
quanto segue**

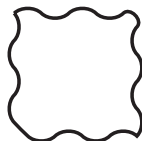

**Figure con telai a cornice
ondulata:
Vista esterna**



**Non è incluso nel volume di
consegna.**

MANUTENZIONE E ASSISTENZA

Pulire periodicamente la serra con un detergente neutro. Il vetro può essere pulito con un detergente, che non intacchi i componenti di plastica né il telaio di alluminio.

Se si dovessero avere dei dubbi circa il detergente da utilizzare, provarlo prima su una piccola superficie lontana dai raggi solari.



Nota:

Per proteggere interamente la serra a titolo preventivo, consigliamo di stipulare un'assicurazione sugli immobili e sul contenuto della casa. Per maggiori informazioni, si prega di rivolgersi al proprio assicuratore.

Informarsi eventualmente sulle norme costruttive locali.

A montaggio ultimato, incollare l'adesivo allegato sul profilo della porta. La denominazione di questo modello è importante per l'ordinazione delle parti di ricambio. Custodire gelosamente le istruzioni d'uso.



Nota:

Seguire attentamente le indicazioni e le avvertenze contenute in queste istruzioni d'uso non avrete difficoltà durante le operazioni di installazione. Se sulle istruzioni d'uso dovessero venire alla luce presunti errori, oppure se un passaggio non è chiaro, rivolgersi al proprio rivenditore o scrivere all'indirizzo di posta elettronica:

Siamo grati per qualsiasi commento o suggerimento.

Vážený zákazníku,

Děkujeme, že jste si vybrali náš produkt.

Jsme přesvědčeni, že vám přinese mnoho radosti.



Před zahájením montáže si kompletně přečtěte tento návod k montáži!

Doporučení**Poznámka**

Zakoupený výrobek je určen k pěstování rostlin a měl by být používán pouze k tomuto účelu. Jakákoli odpovědnost za jiné použití je vyloučena.

Výběr místa

Pro skleník si vyberte co nejslunnější, ale zároveň před větrem chráněné místo. Výběr místa je nesmírně důležitý pro úspěch pěstování a bezpečnost vašeho domu.

0. Základ:

Podrobnosti o základu jsou pouze doporučením.

DŮLEŽITÉ: Vytvořte mrazuvzdornou základnu podle rozměrů uvedených v tabulce.

Pro postavení skleníku potřebujete pevný základ. Tento pevný základ (základ) je možné vyrobit z betonu nebo ze zdiva. Pokud nemáte se zakládáním žádné zkušenosti, obraťte se na odborníka.

Teprve když je vše pod úhlem a smontováno, připojte základnu ke spodnímu rámu podlahy domu.

Než začnete:

Než začnete skleník sestavovat, zkontrolujte, zda jsou k dispozici všechny díly uvedené v seznamu. Jednotlivé svazky vyjměte z obalu, abyste je mohli lépe identifikovat.

Seznam dílů je uspořádán podle krabic.

Je důležité, aby se otevřené svazky nepomíchaly.

Pokud i přes nejpečlivější kontrolu něco chybí, obraťte se na svého dodavatele.

Pokud se zdá, že díl neseďí, nezačínějte s vrtáním nebo řezáním. Obraťte se na svého smluvního partnera.

Odpovědný zákaznický servis vás bude kontaktovat.

Vyhrazujeme si právo na další vývoj v závislosti na technickém pokroku. To může mít za následek drobné odchylky v obrázcích.



Nebezpečí udušení -

Obsahuje malé části

Bezpečnostní pokyny

- Při manipulaci se sklem, dvojitými stěnami nebo díly skleníku vždy používejte ochranné brýle, rukavice, bezpečnostní obuv a ochranu hlavy, protože ostré hrany mohou způsobit zranění. Rozbité sklo představuje bezpečnostní riziko. Odstraňujte je s náležitou opatrností.
- Doporučujeme, aby tento skleník sestavily 2-3 osoby.
- Pozor! Nebezpečí rozdrčení při montáži.
- Nelezte na střešní plochy. Hrozí nebezpečí pádu.
- Montáž se nesmí provádět za silného větru nebo bouřky.
- Skleník musí být vždy ukotven.
- Po 14 dnech zkontrolujte těsnost matic. **14**
- Při silném větru by měly být všechny otvory (okna a dveře) zavřené, jinak bude mít vítr větší prostor k působení.
- Střechy skleníků musí být včas zbaveny sněhu, aby nedocházelo k nebezpečnému zatížení sněhem. V případě silného sněžení musí být střecha co nejrychleji odklizená. V zimě skleník vytápějte.

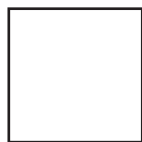

Ilustrace s jednoduchými rámečky: Pohled do interiéru



Důležité upozornění, které je třeba dodržet

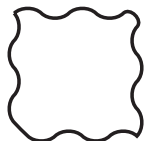

Ilustrace s zvlněným rámečky: Pohled zvenčí



Není součástí kartonu.

Údržba a péče

Skleník by se měl čas od času důkladně umýt neutrálním čisticím prostředkem. Skla lze čistit čisticím prostředkem, který nenarušuje plastové části nebo hliníkový rám.

Pokud si nejste jisti, zda je používaný výrobek kompatibilní, vyzkoušejte jej nejprve na malé ploše mimo dosah slunce.



Nápověda:

Pro plnou ochranu skleníku a obecnou prevenci doporučujeme zahrnout skleník do pojištění domácnosti nebo budovy. Za tímto účelem kontaktujte svého pojistitele.

Zjistěte si informace o stávajících místních stavebních předpisech.

Po montáži nalepte na profil dveří přiloženou nálepku se vzorem. Toto označení modelu je důležité pro případ, že byste později potřebovali náhradní díly. Návod k montáži uschovejte na bezpečném místě!



Nápověda:

Dodržujte přesně informace a pokyny uvedené v tomto návodu k obsluze a při instalaci nebudete mít žádné potíže. Pokud si v návodu k obsluze všimnete chyb nebo vám některá pasáž není jasná, obraťte se na svého prodejce nebo nám napište na následující e-mailovou adresu:

kundendienst@eph-schmidt.de

Jsme vděční za vaše návrhy a podporu.

Kompletní sortiment příslušenství pro skleníky, které vám pomůže tento výrobek co nejlépe využít, je k dispozici u vašeho prodejce. Informujte se o nich.

Drogi Kliencie,

Dziękujemy za wybranie naszego wysokiej jakości produktu.
Jesteśmy przekonani, że przyniesie ci to wiele przyjemności.



Przed przystąpieniem do montażu szklarni należy uważnie i w całości przeczytać niniejszą instrukcję.

ZALECENIA

Uwaga: Zakupiony produkt jest przeznaczony **wyłącznie** do uprawy roślin i powinien być używany **tylko** w tym celu. W przypadku użycia do innych celów nie ponosimy odpowiedzialności.

Wybór miejsca: Zawsze staraj się wybierać nasłonecznioną lokalizację, osłoniętą od wiatru tak bardzo, jak to możliwe. Wybór miejsca jest ważny dla zapewnienia najlepszych wyników podczas uprawy roślin i dla bezpieczeństwa domu.

0. Fundacja: Poniższe specyfikacje fundamentów są jedynie sugestiami.

Ważne: Fundament musi sięgać poniżej poziomu zamarzania.

Do wzniesienia tej szklarni sugerujemy solidny fundament. Możliwe jest przygotowanie takiego fundamentu z betonu, cegły lub kamienia. Jeśli nie masz doświadczenia w budowie takich fundamentów, skonsultuj się z firmą specjalizującą się w takich pracach.

Ważne: Szklarnię należy podłączyć do fundamentu dopiero po jej całkowitym zmontowaniu i sprawdzeniu, czy jest dokładnie ustawiona pod kątem prostym i wypoziomowana.

Przed rozpoczęciem: Przed montażem nowej szklarni należy sprawdzić, czy w zestawie znajdują się wszystkie części wymienione na dostarczonej liście. Prosimy o wyjęcie każdego zestawu z opakowania w celu lepszej identyfikacji części.

Listy części są sortowane według kartonu, w którym zostały dostarczone.

Ważne jest, aby otwarte pakiety nie mieszały się ze sobą.

Jeśli czegoś brakuje, skontaktuj się ze sprzedawcą.

Jeśli okaże się, że część nie pasuje tak, jak pokazano na ilustracji, **nie należy** wprowadzać w niej żadnych zmian. Skontaktuj się ze sprzedawcą, który poprowadzi Cię do odpowiedniego partnera obsługi klienta.

Nasza polityka polega na ciągłym doskonaleniu i zastrzegamy sobie prawo do zmiany specyfikacji bez wcześniejszego powiadomienia. Może to prowadzić do niewielkich różnic między produktem a produktem przedstawionym w niniejszej instrukcji.



Choking Hazard -

0-3 Contains small parts

INFORMACJE DOTYCZĄCE BEZPIECZEŃSTWA

- Ostre krawędzie i narożniki mogą spowodować obrażenia. Podczas pracy z profilami aluminiowymi, szkłem i płytami poliwęglanowymi należy zawsze nosić okulary ochronne, rękawice, obuwie i nakrycie głowy. Potłuczone szkło stanowi zagrożenie dla bezpieczeństwa - należy je natychmiast usunąć i zachować ostrożność.
- Zaleca się, aby ta szklarnia była montowana przez dwie do trzech osób.
- Ważne! Niebezpieczeństwo zmiążdżenia podczas montażu.
- Nie wolno wchodzić na powierzchnie dachu. Istnieje niebezpieczeństwo upadku.
- Szklarni **nie należy** montować podczas silnego wiatru lub burzy.
- Szklarnia **musi być zawsze** zakotwiczona.
- Po upływie 2 tygodni od zakończenia montażu należy sprawdzić dokręcenie wszystkich śrub i nakrętek. 
- W przypadku silnego wiatru należy zamknąć drzwi i wszystkie otwory wentylacyjne.
- W przypadku obfitych opadów śniegu należy odśnieżać dach budynku lub podjąć odpowiednie środki w celu wsparcia dachu. Ogrzewanie budynku w zimie.



Schematy w pojedynczej ramce przedstawiają widok z wnętrza szklarni.



Ważna wskazówka

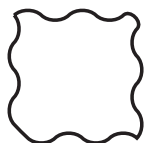

Schematy w falistej ramce przedstawiają widok z zewnątrz szklarni.



Nie jest zawarty w kartonie.

KONSERWACJA

Szklarnię należy od czasu do czasu dokładnie umyć delikatnym detergentem. Szyby można czyścić płynem do mycia szyb. Należy sprawdzić, czy stosowane środki czyszczące nie reagują agresywnie z aluminium lub plastikiem.

Jeśli nie masz pewności, czy środek czyszczący jest odpowiedni, przetestuj go na małej powierzchni z dala od bezpośredniego światła słonecznego.



Uwaga:

Aby zapewnić pełną ochronę nowej szklarni, zalecamy włączenie jej do ubezpieczenia domu. Należy zwrócić uwagę na ewentualne przepisy budowlane dotyczące ustawiania szklarni.

Po pomyślnym zmontowaniu produktu należy przykleić dołączoną etykietę modelu szklarni na listwie drzwi. Informacja ta jest ważna w przypadku konieczności późniejszej wymiany części.

Zachowaj niniejszą instrukcję montażu w bezpiecznym miejscu, aby móc z niej skorzystać w przyszłości!



Uwaga:

Aby uniknąć jakichkolwiek trudności, należy dokładnie przestrzegać instrukcji i wskazówek zawartych w niniejszej instrukcji obsługi. W przypadku wykrycia potencjalnej usterki w niniejszej instrukcji lub znalezienia punktu, który nie został jasno wyjaśniony, należy skontaktować się ze sprzedawcą.

Dziękujemy za sugestie i wsparcie.

Pełna gama akcesoriów szklarniowych, które pomogą Ci w pełni wykorzystać ten produkt, jest dostępna u sprzedawcy. Prosimy o zapoznanie się z nimi.

Spoštovani kupec!

hvala, da ste se odločili za naš izdelek.

Prepričani smo, da vam bo v veliko veselje.



**Prosimo, da ta navodila za postavitve pred začetkom
montaže v celoti preberete!**

PRIPOROČILA

Napitek: Izdelek, ki ste ga kupili, je zasnovan za gojenje rastlin in ga smete uporabljati izključno za ta namen. V primeru drugačne uporabe je vsakršna odgovornost izključena.

Izbira lege: Za vaš rastlinjak poiščite najbolj sončno lego, ki pa je hkrati tudi zaščitena pred vetrom. Izbira kraja postavitve je ozredno pomembna za uspeh gojenja rastlin varnost vaše hiše.

0. Temelj: Navedbe o temelju so samo priporočila.

Temelj mora biti postavljen zaščiteno pred zmrzaljo.

Za postavitve rastlinjaka potrebujete stabilno podnožje. To stabilno podnožje (temelj) lahko izdelate iz betona ali v obliki zidu. Če nimate izkušenj s temeljenjem, se obrnite na strokovnjaka.

Šele ko je vse pod pravim kotom in montirano, spojite podnožje s talnim okvirjem rastlinjaka.

Preden začnete: Preden začnete z montažo vašega rastlinjaka, preverite, ali so na voljo vsi deli, ki so navedeni na seznamu. Da boste to lažje ugotovili, vzemite posamezne pakete iz embalaže.

Seznam delov je razčlenjen po škatlah.

Pomembno je, da odprtih paketov ne pomešate.

Če kljub najskrbnejšemu pregledu kaj manjka, stopite v stik z dobaviteljem.

Če se kdaj zgodi, da menite, da določen del ne ustreza, ne začnite vrtati ali žagati. Stopite v stik z vašim pogodbenim partnerjem. Služba za stranke, ki je pristojna za vas, bo vzpostavila stik z vami.

Pridržujemo si pravico do nadaljnjega razvoja v smislu tehničnega napredka. Tako se lahko pojavijo manjša odstopanja v prikazih.



Nevarnost zadušitve -
Vsebuje majhne dele

VARNOSTNA NAVODILA

- Pri rokovanju s steklom, votlimi ploščami ali deli rastlinjaka morate vedno nositi zaščitna očala, rokavice, zaščitne rokavice in zaščito za glavo, ker se lahko na ostrih robovih poškodujete. Zlomljeno steklo predstavlja varnostno tveganje. Odstranite ga z potrebno previdnostjo.
- Priporočamo vam, da rastlinjak postavijo 2 do 3 osebe.
- Pozor! Nevarnost stisnjenja pri montaži.
- Pri vgradnji zasteklitve dodatno nosite zaščitna očala.
- Ne plezajte na strešne površine. Obstaja nevarnost padca.
- Montaža se ne sme izvajati ob močnem vetru ali viharju.
- Po 2 tednih dodatno zategnite vse vijačne spoje.
- Rastlinjak mora biti vedno sidran.
- Po 14 dneh preverite stabilno prileganje matic. 
- S streh rastlinjakov pravočasno očistite sneg, da ne pride do nevarne obremenitve s snegom. Ob močnih snežnih padavinah mora biti streha čim prej očiščena.
- Ob močnem vetru je treba vse odprtine (okna in vrata) zapreti, ker sicer veter deluje na večjo površino.
- Pozimi rastlinjak ogrevajte.



Op de tekeningen met het enkelvoudige frame wordt de binnenkant van de kas getoond.



Belangrijke tip, in acht nemen a.u.b.:

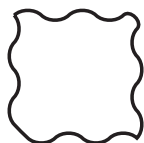

Op de tekeningen met het dubbele frame wordt de buitenkant van de kas getoond.



Ni priložen.

VZDRŽEVANJE IN NEGA

Rastlinjak občasno temeljito operite z nevtralnimi čistilom. Steklo lahko očistite s čistilnim sredstvom, ki ni agresivno do plastičnih delov in aluminijastega okvirja.

Če niste prepričani, ali je sredstvo, ki ga uporabljate, neagresivno, ga najprej preizkusite na majhnem mestu, ki ni izpostavljeno soncu.

Napotek:



Za popolno zaščito rastlinjaka in splošno preventivo vam priporočamo, da rastlinjak vključite v zavarovanje hiše in opreme. V zvezi s tem se obrnite na vašo zavarovalnico.

Pozanimajte se o morebitnih veljavnih lokalnih gradbenih predpisih.

Prosimo, da priloženo tipsko nalepko po postavitvi nalepite na profil vrat. Ta oznaka modela je pomembna, če bi pozneje potrebovali nadomestne dele. Navodila za montažo dobro shranite!



Natančno sledite navedbam in opozorilom teh navodil za uporabo in pri montaži ne boste imeli težav. Če menite, da so v navodilih za uporabo napake ali vam določen odstavek ni jasen, se obrnite na vašega prodajalca ali nam pišite na e-poštni naslov:

kundendienst@eph-schmidt.de

Za vaše pobude in podporo vam bomo hvaležni.

Kedves Ügyfél,
Köszönjük, hogy minőségi termékünket választotta.
Biztosak vagyunk benne, hogy sok örömet fog okozni Önnek.



Kérjük, hogy az üvegház összeszerelése előtt figyelmesen és teljesen olvassa el ezeket az utasításokat.

AJÁNLÁSOK

Megjegyzés: Az Ön által megvásárolt termék **kizárólag** növénytermesztésre szolgál, és **csak** erre a célra használható. Más célú felhasználás esetén nem vállalunk felelősséget.

Helyszín kiválasztása: A lehető legjobban védett, napos, szélvédett helyet válasszunk. A hely kiválasztása fontos a legjobb eredmények biztosítása érdekében a növények termesztése során, valamint a ház biztonsága érdekében.

0. Alapítvány: Az alábbi alapozási előírások csak javaslatok.

Fontos: Az alapozásnak a fagypontra alá kell nyúlnia.

Ennek az üvegháznak a felállításához szilárd alapot javasolunk. Ezt az alapot betonból, téglából vagy kőből lehet elkészíteni. Ha nincs tapasztalata ilyen alapozás készítésében, kérjük, forduljon egy erre a munkára szakosodott céghez.

Fontos: Az üvegházat csak akkor szabad az alaphoz csatlakoztatni, ha az üvegház teljesen össze van szerelve, és ellenőrizni kell, hogy pontosan megfelelő szögben és vízszintesen áll-e.

Mielőtt elkezdené: Mielőtt összeszerelné új üvegházát, kérjük, ellenőrizze, hogy a mellékelt listában szereplő összes alkatrész megtalálható-e. Kérjük, vegye ki az egyes csomagokat a csomagolásból, hogy az alkatrészeket jobban azonosítani tudja.

Az alkatrészlisták aszerint vannak rendezve, hogy milyen kartondobozban szállítják őket.

Fontos, hogy a felbontott kötegek ne keveredjenek egymással.

Ha valami hiányzik, kérjük, forduljon a kiskereskedőhöz.

Ha úgy találja, hogy egy alkatrész nem úgy illik a képen látható módon, ne változtasson rajta. Kérjük, forduljon a kereskedőjéhez, aki a megfelelő ügyfélszolgálati partnerhez irányítja Önt.

Politikánk a folyamatos fejlesztés politikája, és fenntartjuk a jogot, hogy a specifikációkat előzetes értesítés nélkül megváltoztassuk. Ez kisebb eltéréseket eredményezhet az Ön terméke és a jelen kézikönyvben bemutatott termék között.



Fulladásveszély
- Apró alkatrészeket
tartalmaz

BIZTONSÁGI KÖZLEMÉNY

- Az éles élek és sarkok sérülést okozhatnak. Az alumíniumprofilok, üveg- és polikarbonátlemezek kezelésénél mindig viseljen védőszemüveget, kesztyűt, cipőt és fejfedőt. A törött üveg biztonsági kockázatot jelent - mindig azonnal takarítsa el, és óvatosan ártalmatlanítsa.
- Ajánlott, hogy ezt az üvegházat két-három személy szerelje össze.
- **Fontos!** Összeszerelés közbeni összenyomódás veszélye.
- Ne másszon fel a tetőfelületekre. Fennáll a lezuhanás veszélye.
- Az üvegházat nem szabad összeszerelni erős szél vagy vihar esetén.
- Az üvegházat mindig le kell horgonyozni.
- Kérjük, hogy az összeszerelés befejezése után 2 héttel ellenőrizze az összes anyacsavar és csavar feszességét.
- Erős szél esetén zárja be az ajtókat és az összes szellőzőnyílást.
- Erős havazás esetén tisztítsa meg az épület tetejét, vagy tegyen megfelelő intézkedéseket a tető alátámasztására. Télen fűtse az épületet.

14

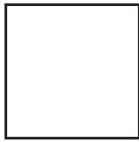

Az egyetlen keretben lévő ábrák az üvegház belsejéből mutatják a kilátást.



Fontos tipp, kérjük, vegye figyelembe

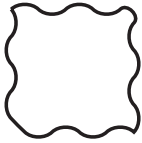

A hullámos keretben lévő ábrák az üvegházon kívüli kilátást mutatják.



Nem tartalmazza a kartondoboz.

KARBANTARTÁS

Az üvegházat időnként kíméletes mosószerrel alaposan ki kell mosni. Az üvegeket üveg tisztítóval lehet tisztítani. Kérjük, ellenőrizze, hogy a használt tisztítószer ne lépjen-e agresszív reakcióba az alumíniummal vagy műanyaggal.

Ha nem biztos benne, hogy a tisztítószer megfelelő, kérjük, próbálja ki egy kis, közvetlen napfénytől védett területen.



Megjegyzés:

Az új üvegház teljes körű védelme érdekében javasoljuk, hogy kösse be a házbiztosításába. Kérjük, vegye figyelembe az üvegházak elhelyezésére vonatkozó esetleges építési szabályokat.

Kérjük, a termék sikeres összeszerelése után ragassza fel a mellékelt üvegházmodell címkét az ajtórúdra. Ez az információ fontos abban az esetben, ha később cserealkatrészekre van szükség.

Kérjük, hogy a jövőbeni használatra őrizze meg ezt az összeszerelési útmutatót biztonságos helyen!



Megjegyzés:

Kérjük, hogy a nehézségek elkerülése érdekében pontosan kövesse a jelen használati útmutatóban található utasításokat és tippeket. Amennyiben ebben a kézikönyvben esetleges hibát talál, vagy olyan pontot, amely nem egyértelműen magyarázott, kérjük, forduljon a kereskedőhöz.

Nagyra értékeljük javaslatait és támogatását.

Az üvegházi tartozékok teljes választéka, amelyek segítenek Önnek a lehető legtöbbet kihozni ebből a termékből, kapható a raktárkészleten. Kérjük, tájékozódjon ezekről.

Poštovani kupci,

Hvala vam što ste odabrali naš proizvod.

Uvjereni smo da će vam pružiti puno zadovoljstva



Prije početka montaže u potpunosti pročitajte ove upute za montažu!

PREPORUKAMA

Napomena: Proizvod koji kupite namijenjen je uzgoju biljaka i treba ga koristiti **isključivo** u tu svrhu. Svaka odgovornost je isključena za drugu upotrebu.

Izbor lokacije: Odaberite najsunčanije, ali i zaštićeno mjesto za svoj staklenik. Izbor lokacije iznimno je važan za uspjeh uzgoja i sigurnost vašeg doma.

0. Temelj: Podaci o zakladi su samo preporuke.

Temelj mora biti utemeljen bez smrzavanja.

Da biste postavili staklenik, potrebna vam je fiksna baza. Ovu čvrstu podlogu (temelj) moguće je napraviti od betona ili zida. Ako nemate iskustva s radovima na temeljima, obratite se stručnjaku.

Tek kad je sve pod kutom i potpuno sastavljeno, povezujete bazu s okvirom donjeg kata kuće.

Prije nego što započnete:

Prije nego što počnete sastavljati staklenik, provjerite jesu li svi dijelovi na popisu na svom mjestu. Izvadite pojedinačne snopove iz pakiranja kako biste ih lakše prepoznali.

Popis dijelova podijeljen je u okvire.

Važno je da se otvoreni snopovi ne pomiješaju.

Ako nešto nedostaje unatoč najpažljivijoj provjeri, obratite se svom dobavljaču.

Ako se ikada dogodi da dio navodno ne odgovara, **nemojte** početi bušiti ili piliti. Obratite se svom ugovornom partneru. Vaša služba za korisnike će vas kontaktirati.

Zadržavamo pravo daljnjeg razvoja u smislu tehničkog napretka. To može rezultirati malim odstupanjima u prikazima.



Opasnost od gušenja
- Sadrži male
dijelove

SIGURNOST

- Prilikom rukovanja staklom, valovitim pločama ili dijelovima staklenika uvijek se moraju nositi zaštitne naočale, rukavice, zaštitne cipele i zaštita za glavu jer oštri rubovi mogu dovesti do ozljeda. Razbijeno staklo predstavlja sigurnosni rizik. Uklonite ga s dužnim oprezom.
- Preporučuje se da ovaj staklenik grade 2-3 osobe.
- Pažnja! Opasnost od prignječenja tijekom instalacije.
- Na krovne površine ne smije se ulaziti. Postoji opasnost od pada.
- Instalacija se **ne smije** izvoditi po jakom vjetru ili oluji.
- Staklenik uvijek **mora biti** usidren.
- Nakon 14 dana provjerite čvrsto prianjanje matica. **14**
- Pri jakom vjetru svi otvori (prozori i vrata) trebaju biti zatvoreni, inače će vjetar imati više površine za napad.
- Krovovi staklenika moraju se pravodobno očistiti od snijega kako ne bi došlo do opasnog onečišćenja snijegom. U slučaju obilnih snježnih padalina, krov se mora očistiti što je brže moguće. Zagrijte staklenik zimi.

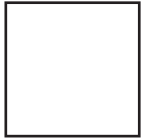

Slike s jednostavnim okvirom: pogled iznutra.



Važna napomena, mora se pridržavati

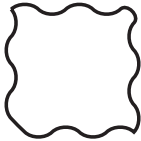

Slike s valovitim okvirom: Vanjski pogled.



Nije uključeno.

ODRŽAVANJE I NJEGA

Staklenik treba s vremena na vrijeme temeljito oprati neutralnim deterdžentom. Staklo se može očistiti sredstvom za čišćenje koje ne napada plastične dijelove ili aluminijski okvir.

Ako niste sigurni je li proizvod koji koristite podnošljiv, prvo ga testirajte na malom prostoru okrenutom od sunca.



Nagovještaj:

Za potpunu zaštitu staklenika i za opću prevenciju, preporučujemo da staklenik uključite u svoje osiguranje kućanstva ili zgrade. U tu svrhu obratite se svom osiguravatelju.

Saznajte više o lokalnim građevinskim propisima koji mogu postojati.

Nakon montaže zalijepite priloženu naljepnicu na profil vrata. Ova oznaka modela važna je u slučaju da vam kasnije zatrebaju rezervni dijelovi. Čuvajte upute za sastavljanje!



Nagovještaj:

Molimo slijedite točno upute i savjete navedene u ovom priručniku s uputama kako biste izbjegli bilo kakve poteškoće. Ako pronadete potencijalni kvar u ovom priručniku ili pronadete točku koja nije jasno objašnjena, obratite se svom prodavaču.

Cijenimo vaše prijedloge i podršku.

Cijeli asortiman dodataka za staklenike, koji će vam pomoći da maksimalno iskoristite ovaj proizvod, dostupan je kod vašeg prodavača. Budite svjesni toga.

Dragi kupci,
Hvala vam što ste odabrali naš proizvod.
Uvjereni smo da će vam pružiti puno zadovoljstva.



Molimo pročitajte ove upute za montažu u potpunosti prije početka montaže!

PREPORUKE

Napomena: Proizvod koji kupite je dizajniran za uzgoj biljaka i treba ga koristiti **isključivo** u tu svrhu. Svaka odgovornost je isključena za drugu upotrebu.

Izbor lokacije: Odaberite najsunčanije, ali i mjesto zaštićeno od vjetra za vaš staklenik. Izbor lokacije je izuzetno važan za uspjeh uzgoja i sigurnost vašeg doma.

0. Fondacija: Informacije o fondaciji su samo preporuke.

Temelj mora biti postavljen bez smrzavanja.

Da biste postavili staklenik, potrebna vam je fiksna baza. Moguće je napraviti ovu čvrstu podlogu (temelj) od betona ili zida. Ako nemate iskustva s radom na temeljima, obratite se stručnjaku.

Tek kada je sve pod kutom i potpuno sastavljeno, spojite bazu na donji kat okvira kuće.

Prije nego što počnete:

Prije nego što počnete sastavljati svoj staklenik, provjerite jesu li svi dijelovi na popisu na mjestu. Uklonite pojedinačne snopove iz ambalaže kako biste ih lakše identificirali.

Lista dijelova je podijeljena u kutije.

Važno je da se otvoreni snopovi ne pomiješaju.

Ako nešto nedostaje unatoč najpažljivijoj provjeri, obratite se svom dobavljaču.

Ako se ikada dogodi da dio navodno ne odgovara, **nemojte** početi bušiti ili piliti. Obratite se svom ugovornom partneru. Vaša služba za korisnike će vas kontaktirati.

Zadržavamo pravo daljeg razvoja u smislu tehničkog napretka. To može rezultirati malim odstupanjima u prikazima.



Opasnost od gušenja
- Sadrži male
dijelove

SIGURNOST

- Prilikom rukovanja staklom, valovitim pločama ili dijelovima staklenika, uvijek se moraju nositi zaštitne naočale, rukavice, zaštitne cipele i zaštita za glavu, jer oštri rubovi mogu dovesti do ozljeda. Razbijeno staklo predstavlja sigurnosni rizik. Molim vas, eliminirajte ga s dužnim oprezom.
- Preporučuje se da ovaj staklenik grade 2-3 osobe.
- Pažnja! Rizik od gnječenja tokom instalacije.
- Krovne površine se ne smiju ulaziti. Postoji opasnost od pada.
- Instalacija se **ne smije** izvoditi po jakom vjetru ili oluji.
- Staklenik mora **uvijek** biti usidren.
- Nakon 14 dana, provjerite čvrsto pritanjanje matica. **14**
- Pri jakom vjetru, svi otvori (prozori i vrata) trebaju biti zatvoreni, inače će vjetar imati više površine za napad.
- Krovovi staklenika moraju biti očišćeni od snijega na vrijeme kako ne bi došlo do opasnog zagađenja snijegom. U slučaju obilnih snježnih padavina, krov mora biti očišćen što je brže moguće. Zagrijte staklenik zimi.



Slike s jednostavnim okvirom: pogled iznutra.



Važna napomena, mora se poštovati

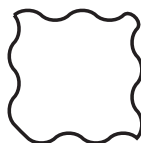

Slike sa valovitim okvirom: Vanjski pogled.



Nije uključeno.

ODRŽAVANJE I NJEGA

Staklenik treba temeljito oprati neutralnim deterdžentom s vremena na vrijeme. Staklo se može očistiti sredstvom za čišćenje koje ne napada plastične dijelove ili aluminijski okvir.

Ako niste sigurni da li je proizvod koji koristite podnošljiv, prvo ga testirajte na malom području okrenutom od sunca.



Nagovještaj:

Za potpunu zaštitu staklenika i za opću prevenciju, preporučujemo da uključite staklenik u svoje domaćinstvo ili osiguranje zgrade. Obratite se svom osiguravatelju u tu svrhu.

Saznajte više o svim lokalnim građevinskim propisima koji mogu postojati.

Molimo vas da zalijepite priloženu naljepnicu na profil vrata nakon montaže. Ova oznaka modela je važna u slučaju da vam kasnije trebaju rezervni dijelovi. Čuvajte upute za sastavljanje na sigurnom!



Nagovještaj:

Molimo vas da se tačno pridržavate uputstava i savjeta u ovom priručniku kako biste izbjegli bilo kakve poteškoće. Ako pronadete potencijalni kvar u ovom priručniku ili pronadete točku koja nije jasno objašnjena, obratite se svom prodavaču.

Cijenimo vaše prijedloge i podršku.

Cijeli asortiman dodataka za staklenike, koji će vam pomoći da maksimalno iskoristite ovaj proizvod, dostupan je kod vašeg prodavača. Molimo vas da se toga upoznate.

Stimate client,

Vă mulțumim pentru alegerea produsului nostru de calitate.
Suntem încrezători că vă va aduce o mulțime de plăcere.



Vă rugăm să citiți cu atenție și complet aceste instrucțiuni înainte de a asambla sera.

RECOMANDĂRI

Notă: Produsul pe care l-ați achiziționat este destinat **exclusiv** cultivării plantelor și trebuie utilizat **numai** în acest scop. În cazul în care este utilizat în alte scopuri, nu ne asumăm nicio responsabilitate.

Selectarea amplasamentului: Încercați întotdeauna să selectați un loc însorit, ferit de vânt pe cât posibil. Alegerea locului este importantă pentru a asigura cele mai bune rezultate la cultivarea plantelor și pentru siguranța casei dumneavoastră.

0. Fundație: Următoarele specificații privind fundația sunt doar sugestii.

Important: fundația trebuie să se afle sub nivelul de îngheț.

Pentru ridicarea acestei sere sugerăm o fundație solidă. Este posibil să pregătiți această fundație din beton, cărămidă sau piatră. Dacă nu aveți experiență în construirea unei astfel de fundații, vă rugăm să consultați o companie specializată în această activitate.

Important: Sera trebuie conectată la fundație numai după ce este complet asamblată și după ce a fost verificată dacă are unghiul și nivelul corecte.

Înainte de a începe:

Înainte de asamblarea noii dvs. sere, vă rugăm să verificați dacă sunt incluse toate piesele din listele furnizate. Vă rugăm să scoateți fiecare pachet din ambalaj pentru a identifica mai bine piesele.

Listele de piese sunt sortate în funcție de cartonul în care sunt livrate.

Este important ca pachetele deschise să nu se amestece între ele.

Dacă lipsește ceva, vă rugăm să contactați distribuitorul.

Dacă constatați că o piesă nu se potrivește așa cum este prezentată, **nu** faceți nicio modificare la piesă. Vă rugăm să contactați comerciantul dvs. cu amănuntul, care vă va îndruma către partenerul relevant de servicii pentru clienți.

Politica noastră este una de îmbunătățire continuă și ne rezervăm dreptul de a modifica specificațiile fără notificare prealabilă. Acest lucru poate duce la mici diferențe între produsul dvs. și cel prezentat în acest manual.



Pericol de sufocare
- Conține piese mici

NOTIFICARE PRIVIND SIGURANȚA

- **Marginile și colțurile ascuțite pot provoca răniri. Purtați întotdeauna ochelari, mănuși, pantofi și cască de protecție atunci când manipulați profilele de aluminiu, sticla și plăcile de policarbonat. Sticla spartă reprezintă un pericol pentru siguranță - curățați-o întotdeauna imediat și eliminați-o cu grijă.**
- **Se recomandă ca această seră să fie asamblată de două până la trei persoane.**
- **Important! Pericol de strivire în timpul asamblării.**
- **Nu vă urcați pe suprafețele acoperișului. Există pericolul de cădere.**
- **Sera nu trebuie asamblată în condiții de vânt puternic sau furtună.**
- **Sera trebuie să fie întotdeauna ancorată.**
- **Vă rugăm să verificați etanșeitatea tuturor piulițelor și șuruburilor la 2 săptămâni după finalizarea asamblării.**
- **În caz de vânt puternic, închideți ușile și toate orificiile de ventilație.**
- **În caz de căderi abundente de zăpadă, curățați acoperișul clădirii sau luați măsuri adecvate pentru susținerea acoperișului. Încălziți clădirea în timpul iernii.**

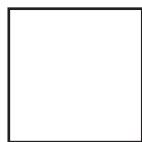

Diagramele dintr-un singur cadru prezintă vederea din interiorul serei.



Sfat important, vă rugăm să luați notă

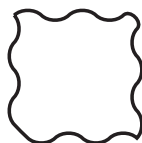

Diagramele într-un cadru ondulat prezintă vederea din afara serei.



Nu este inclus în cutie.

ÎNTREȚINERE

Sera trebuie spălată bine ocazional cu un detergent delicat. Sticla poate fi curățată cu detergent pentru sticlă. Vă rugăm să verificați dacă agenții de curățare utilizați nu reacționează agresiv cu aluminiul sau plasticul.

Dacă nu sunteți sigur dacă agentul de curățare este adecvat, vă rugăm să îl testați pe o suprafață mică, ferită de lumina directă a soarelui.



Notă:

Pentru protecția completă a noii dvs. sere, vă sfătuim să o includeți în asigurarea casei dvs. Vă rugăm să țineți cont de eventualele norme de construcție referitoare la amplasarea serelor.

Vă rugăm să lipiți eticheta modelului de seră inclusă pe bara ușii după asamblarea cu succes a acestui produs. Această informație este importantă în cazul în care ulterior sunt necesare piese de schimb.

Vă rugăm să păstrați aceste instrucțiuni de asamblare într-un loc sigur, pentru consultare ulterioară!



Notă:

Vă rugăm să urmați întocmai instrucțiunile și sfaturile furnizate în acest manual de instrucțiuni pentru a evita orice dificultăți. În cazul în care găsiți o posibilă defecțiune în acest manual sau găsiți un punct care nu este explicat clar, vă rugăm să contactați comerciantul dvs.

Apreciem sugestiile și sprijinul dumneavoastră.

O gamă completă de accesorii pentru sere, pentru a vă ajuta să profitați la maximum de acest produs, este disponibilă la distribuitorul dumneavoastră. Vă rugăm să luați cunoștință de acestea.

Vážený zákazník,
 Ďakujeme, že ste si vybrali náš kvalitný výrobok.
 Sme presvedčení, že vám prinesie veľa radosti.



Pred zostavením skleníka si pozorne a úplne prečítajte tieto pokyny.

ODPORÚČANIA

Poznámka: Zakúpený výrobok je určený **len** na pestovanie rastlín a mal by sa používať **len** na tento účel. Pri použití na iné účely nenesieme žiadnu zodpovednosť.

Výber miesta: Vždy sa snažte vybrať slnečné miesto, čo najviac chránené pred vetrom. Výber miesta je dôležitý pre zabezpečenie najlepších výsledkov pri pestovaní rastlín a pre bezpečnosť vášho domu.

0. Nadácia: Nasledujúce špecifikácie základov sú len návrhy.

Dôležité: Základy musia siahať pod úroveň mrazu.

Na postavenie tohto skleníka odporúčame pevný základ. Tento základ je možné pripraviť z betónu, tehál alebo kameňa. Ak nemáte skúsenosti s výstavbou takéhoto základu, obráťte sa na firmu, ktorá sa na tieto práce špecializuje.

Dôležité: Skleník by sa mal pripojiť k základom až po kompletnej zostavení skleníka a po kontrole, či je presne v správnom uhle a rovine.

Skôr ako začnete:

Pred zostavením nového skleníka skontrolujte, či sú v ňom obsiahnuté všetky diely uvedené v priložených zoznamoch. Každý zväzok vyberte z obalu, aby ste mohli lepšie identifikovať jednotlivé diely.

Zoznamy dielov sú zoradené podľa kartónu, v ktorom sa dodávajú.

Je dôležité, aby sa otvorené zväzky navzájom nemiešali.

Ak niečo chýba, obráťte sa na svojho predajcu.

Ak zistíte, že niektorý diel nesedí tak, ako je znázornené, **nevykonávajte na ňom žiadne** zmeny. Obráťte sa na svojho predajcu, ktorý vás nasmeruje na príslušného partnera zákazníckeho servisu.

Našou politikou je neustále zlepšovanie a vyhradzuje si právo zmeniť špecifikácie bez predchádzajúceho upozornenia. To môže viesť k malým rozdielom medzi vašim výrobkom a výrobkom uvedeným v tejto príručke.



Nebezpečenstvo
 udusenía - obsahuje
 malé časti

BEZPEČNOSTNÉ ÚPOZORNENIE

- Ostré hrany a rohy môžu spôsobiť poranenie. Pri manipulácii s hliníkovými profilmi, sklom a polykarbonátovými doskami vždy používajte ochranné okuliare, rukavice, obuv a pokrývku hlavy. Rozbité sklo predstavuje bezpečnostné riziko - vždy ho okamžite odstráňte a opatrne zlikvidujte.
- Odporúča sa, aby tento skleník montovali dve až tri osoby.
- Dôležité! Nebezpečenstvo rozdrvenia počas montáže.
- Nevyliezajte na strešné plochy. Hrozí nebezpečenstvo pádu.
- Skleník by sa nemal montovať počas silného vetra alebo búrky.
- Skleník musí byť vždy ukotvený.
- Po 2 týždňoch od dokončenia montáže skontrolujte utiahnutie všetkých matíc a skrutiek.
- V prípade silného vetra zatvorte dvere a všetky vetracie otvory.
- V prípade silného sneženia odstráňte strechu budovy alebo prijmite vhodné opatrenia na podopretie strechy. V zime budovu vykurojte.

14



Schémy v jednom rámečku zobrazujú pohľad zvnútra skleníka.



Dôležitý tip, prosím, berte na vedomie

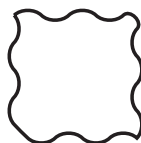

Schémy vo zvlnenom rámečku zobrazujú pohľad zvonku skleníka.



Nie je súčasťou kartónu.

ÚDRŽBA

Skleník by sa mal občas dôkladne umyť jemným čistiacim prostriedkom. Sklo sa môže čistiť čistiacim prostriedkom na sklo. Skontrolujte, či použité čistiace prostriedky nereagujú agresívne s hliníkom alebo plastom.

Ak si nie ste istí, či je čistiaci prostriedok vhodný, vyskúšajte ho na malej ploche mimo priameho slnečného svetla.



Poznámka:

Pre úplnú ochranu vášho nového skleníka vám odporúčame zahrnúť ho do poistenia domu. Vezmite prosím na vedomie prípadné stavebné predpisy týkajúce sa umiestnenia skleníkov.

Po úspešnej montáži tohto výrobku nalepte na lištu dverí priložený štítok s modelom skleníka. Táto informácia je dôležitá pre prípad, že by neskôr boli potrebné náhradné diely.

Uschovajte si tento návod na montáž na bezpečnom mieste, aby ste ho mohli v budúcnosti použiť!



Poznámka:

Aby ste sa vyhli akýmkoľvek ťažkostiam, dodržiavajte presne pokyny a tipy uvedené v tomto návode na použitie. Ak by ste v tomto návode našli prípadnú chybu alebo by ste našli bod, ktorý nie je jasne vysvetlený, obráťte sa na svojho predajcu.

Oceňujeme vaše návrhy a podporu.

Kompletný sortiment príslušenstva pre skleníky, ktorý vám pomôže čo najlepšie využiť tento výrobok, je k dispozícii u vášho predajcu. Informujte sa o nich.

Уважаемый клиент,
Спасибо, что выбрали наш качественный продукт.
Мы уверены, что он доставит вам массу удовольствия.



Перед сборкой теплицы внимательно и полностью прочитайте эту инструкцию.

РЕКОМЕНДАЦИИ

Примечание: Приобретенный вами продукт предназначен **только** для выращивания растений и должен использоваться **только** для этой цели. При использовании в других целях мы не несем никакой ответственности.

Выбор места: Всегда старайтесь выбирать солнечное место, максимально защищенное от ветра. Выбор места важен для достижения наилучших результатов при выращивании растений и для безопасности вашего дома.

0. Фонд: Приведенные ниже характеристики фундамента являются лишь предположениями.

Важно: фундамент должен быть ниже уровня промерзания почвы.

Для возведения этой теплицы мы предлагаем прочный фундамент. Его можно подготовить из бетона, кирпичной или каменной кладки. Если у вас нет опыта строительства такого фундамента, обратитесь в компанию, специализирующуюся на этих работах.

Важно: теплицу следует присоединять к фундаменту только после того, как она полностью собрана и проверена на правильность углов и уровня.

Прежде чем начать: Перед сборкой новой теплицы проверьте, все ли детали, указанные в списке, включены в комплект. Пожалуйста, достаньте каждый комплект из упаковки, чтобы лучше определить детали.

Списки деталей сортируются в соответствии с коробкой, в которой они поставляются.

Важно, чтобы открытые свертки не смешивались друг с другом.

Если что-то отсутствует, обратитесь к продавцу.

Если вы обнаружили, что деталь не подходит, как показано на рисунке, **не** вносите в нее никаких изменений. Обратитесь к своему продавцу, который направит вас к соответствующему партнеру по обслуживанию клиентов.

Мы придерживаемся политики постоянного совершенствования и оставляем за собой право изменять технические характеристики без предварительного уведомления. Это может привести к небольшим различиям между вашим изделием и изделием, представленным в данном руководстве.



Опасность удушья
- содержит мелкие
детали

УВЕДОМЛЕНИЕ О БЕЗОПАСНОСТИ

- Острые края и углы могут стать причиной травм. При работе с алюминиевыми профилями, стеклом и листами поликарбоната всегда надевайте защитные очки, перчатки, обувь и головной убор. Разбитое стекло представляет собой угрозу безопасности - всегда немедленно убирайте его и утилизируйте с осторожностью.
- Рекомендуется, чтобы эту теплицу собирали два-три человека.
- **Внимание!** Опасность защемления при сборке.
- Не забирайтесь на крышу. Существует опасность падения.
- **Не** следует собирать теплицу во время сильного ветра или шторма.
- Теплица **всегда** должна быть закреплена.
- Пожалуйста, проверьте затяжку всех гаек и болтов через 2 недели после завершения сборки.
- В случае сильного ветра закройте двери и все вентиляционные отверстия.
- В случае сильного снегопада очистите крышу здания или примите соответствующие меры для ее поддержки. Отапливайте здание зимой.

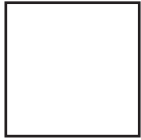

Диаграммы в одном кадре показывают вид изнутри теплицы.



Важный совет, пожалуйста, примите к сведению

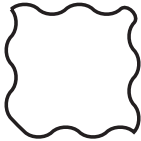

Диаграммы в волнистой рамке показывают вид снаружи теплицы.



В коробку не входит.

ТЕХНИЧЕСКОЕ ОБСЛУЖИВАНИЕ

Оранжерею следует периодически тщательно мыть с мягким моющим средством. Стекло можно чистить средством для мытья стекол. Убедитесь, что используемые чистящие средства не вступают в агрессивную реакцию с алюминием или пластиком.

Если вы не уверены в том, что чистящее средство подходит, протестируйте его на небольшом участке вдали от прямых солнечных лучей.



Примечание:

Для полной защиты вашей новой теплицы мы советуем вам включить ее в страховку дома. Пожалуйста, обратите внимание на возможные строительные нормы, касающиеся размещения теплиц.

После успешной сборки изделия наклейте прилагаемую этикетку с моделью теплицы на дверную планку. Эта информация важна на случай, если впоследствии потребуются запасные части.

Сохраните эту инструкцию по сборке в надежном месте для дальнейшего использования!



Примечание:

Во избежание трудностей следуйте инструкциям и советам, приведенным в данном руководстве. Если вы обнаружите в данном руководстве потенциальный сбой или найдете неясные моменты, обратитесь к продавцу.

Мы ценим ваши предложения и поддержку.

Полный ассортимент аксессуаров для теплиц, которые помогут вам максимально эффективно использовать этот продукт, можно приобрести у вашего продавца. Пожалуйста, ознакомьтесь с ними.

Шановний клієнт,
Дякуємо, що обрали наш якісний продукт.
Ми впевнені, що вона принесе вам багато задоволення.



Будь ласка, уважно та повністю прочитайте цю інструкцію перед тим, як збирати теплицю.

РЕКОМЕНДАЦІЇ

Примітка: Придбаний вами продукт призначений **тільки** для вирощування рослин і повинен використовуватися **тільки** з цією метою. У разі використання в інших цілях ми не несемо жодної відповідальності.

Вибір місця: Завжди намагайтеся вибрати сонячне місце, максимально захищене від вітру. Вибір місця важливий для забезпечення найкращих результатів при вирощуванні ваших рослин і для безпеки вашого будинку.

0. Фундамент: Наведені нижче технічні характеристики фундаменту є лише рекомендаціями.

Важливо: Фундамент повинен заглиблюватися нижче рівня промерзання.

Для зведення цієї теплиці ми рекомендуємо міцний фундамент. Фундамент можна підготувати з бетону, цегляної або кам'яної кладки. Якщо у вас немає досвіду будівництва такого фундаменту, зверніться до компанії, що спеціалізується на таких роботах.

Важливо: Теплицю слід з'єднувати з фундаментом тільки після того, як теплиця буде повністю зібрана і перевірена на правильність кутів і рівність.

Перш ніж ви почнете: Перед складанням нової теплиці, будь ласка, перевірте, чи всі деталі з наданого переліку є в наявності. Будь ласка, вийміть кожну упаковку з пакування, щоб краще ідентифікувати деталі.

Переліки деталей відсортовані відповідно до коробки, в якій вони поставляються.

Важливо, щоб відкриті пакети не змішувалися між собою.

Якщо чогось не вистачає, зверніться до вашого продавця.

Якщо ви виявили, що деталь не підходить, як показано **на** малюнку, **не вносьте** в неї жодних змін. Зверніться до свого продавця, який скерує вас до відповідного партнера з обслуговування клієнтів.

Наша політика спрямована на постійне вдосконалення, і ми залишаємо за собою право змінювати технічні характеристики без попереднього повідомлення. Це може призвести до незначних відмінностей між вашим виробом і тим, що зображено в цьому посібнику.



Небезпека
удушення - містить
дрібні деталі

ЗАСТЕРЕЖЕННЯ З ТЕХНІКИ БЕЗПЕКИ

- Гострі краї та кути можуть спричинити травми. Завжди носіть захисні окуляри, рукавички, взуття та головний убір під час роботи з алюмінієвими профілями, склом і полікарбонатними листами. Бите скло становить загрозу безпеці - завжди негайно прибирайте його та утилізуйте з обережністю.
- Рекомендується, щоб цю теплицю збирали дві-три людини.
- Увага! Небезпека защемлення під час монтажу.
- Не піднімайтеся на поверхні даху. Існує небезпека падіння.
- Теплицю **не слід** збирати під час сильного вітру або шторму.
- Теплиця **завжди** повинна бути закріплена.
- Будь ласка, перевірте затягування всіх гайок і болтів через 2 тижні після завершення збірки.
- У разі сильного вітру закрийте двері та всі вентиляційні отвори.
- У разі сильного снігопаду очистіть дах будівлі або вживіть відповідних заходів для підтримки даху. Опалюйте будівлю взимку.

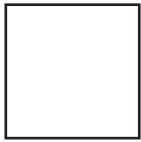

Схеми в одному кадрі показують вигляд зсередини теплиці.



Важлива порада, будь ласка, візьміть до уваги

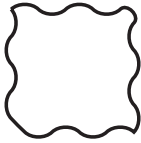

Схеми у хвилястій рамці показують вигляд ззовні теплиці.



Не входить до складу упаковки.

ОБСЛУГОВУВАННЯ

Час від часу теплицю слід ретельно мити м'яким миючим засобом. Скло можна мити засобом для миття скла. Будь ласка, переконайтеся, що використовувані миючі засоби не вступають в агресивну реакцію з алюмінієм або пластиком.

Якщо ви не впевнені, чи підходить засіб для чищення, протестуйте його на невеликій ділянці, захищеній від прямих сонячних променів.



Зауважте:

Для повного захисту вашої нової теплиці ми радимо включити її у страховку вашого будинку. Будь ласка, зверніть увагу на можливі будівельні правила, що стосуються розміщення теплиць.

Після успішного складання теплиці наклейте етикетку з моделлю теплиці, що входить до комплекту, на дверну перекладину. Ця інформація важлива на випадок, якщо згодом знадобляться запасні частини.

Будь ласка, зберігайте цю інструкцію з монтажу в безпечному місці для подальшого використання!



Зауважте:

Щоб уникнути будь-яких труднощів, будь ласка, точно дотримуйтесь інструкцій та порад, наведених у цій інструкції. Якщо ви виявите в цій інструкції потенційну несправність або знайдете пункт, який не має чіткого пояснення, будь ласка, зверніться до продавця.

Ми вдячні за ваші пропозиції та підтримку.

Повний асортимент аксесуарів для теплиць, які допоможуть вам максимально ефективно використовувати цей продукт, доступний у вашого постачальника. Будь ласка, зверніть на це увагу.

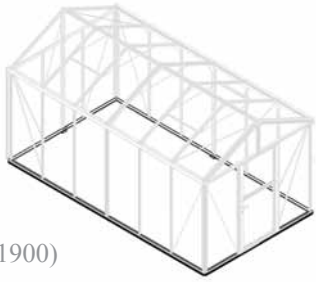

(11900)

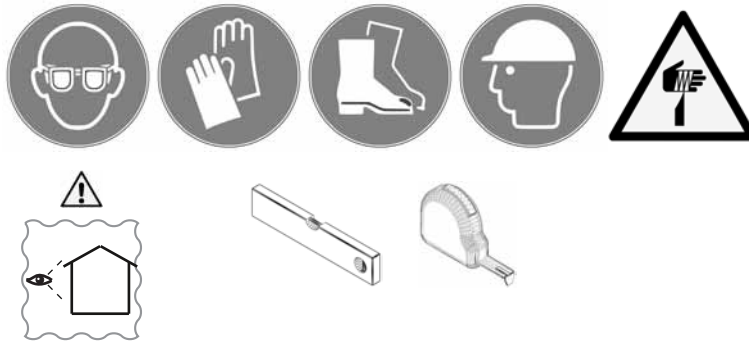

FOUNDATION, FUNDATIONS, FUNDERING, FUNDAMENT / SOKKEĽ, FUNDAMENT / SOKKEĽ, STIFTELSEN,
 SÄÄTIÖ, FUNDAMENTA, NADACE, FUNDACIJA, TEMELJ, ALAPÍTVÁNY, TEMELJ, FONDACIJA, FUNDATIE, NADÁCIA,
 ФОНД, ФУНДАЦІЯ.

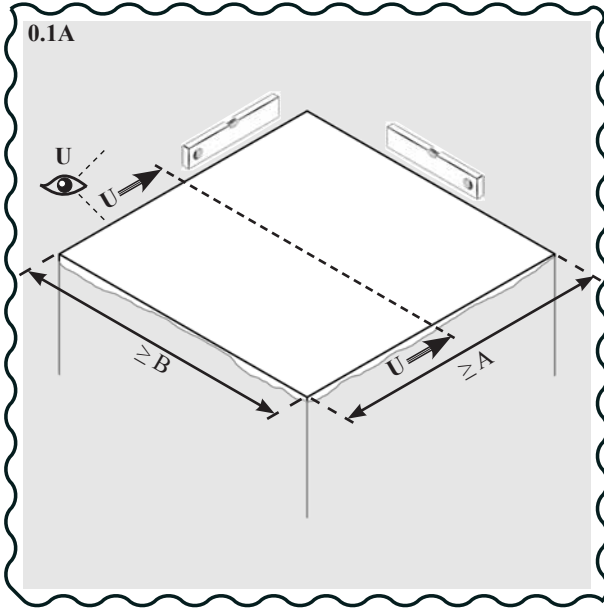

? F1

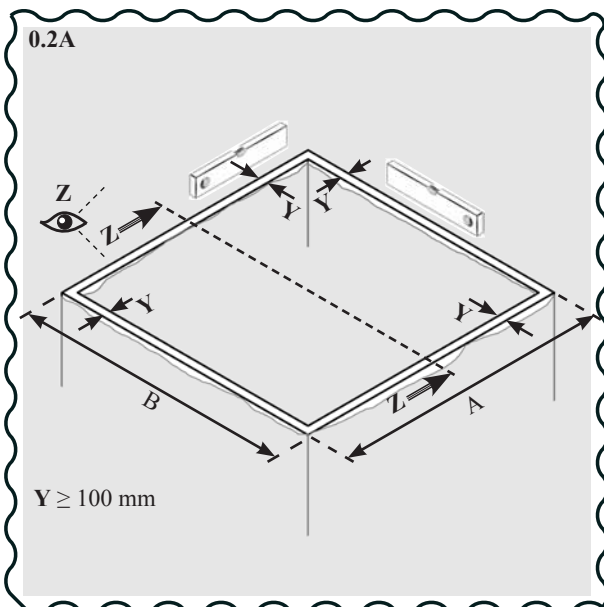
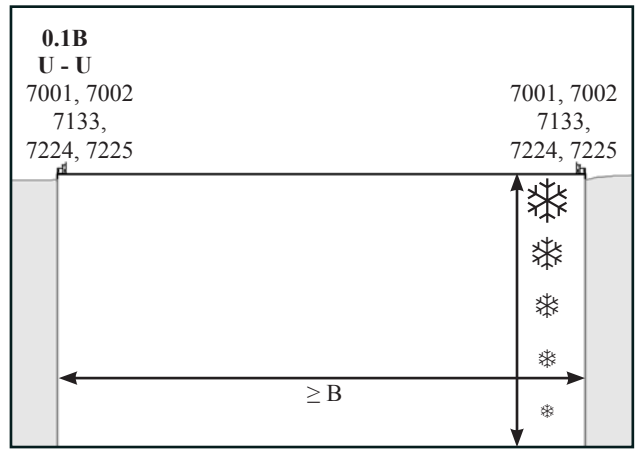

? F2

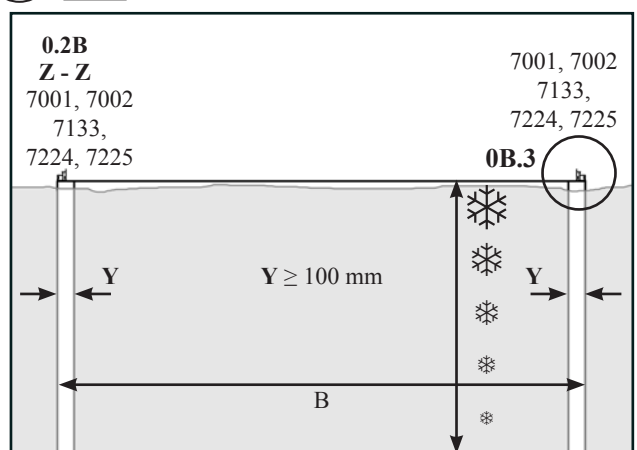

? Alternative options View from

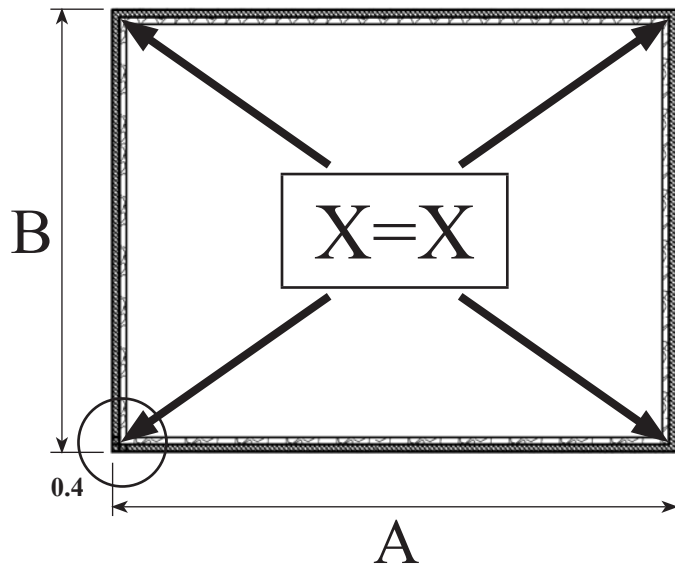
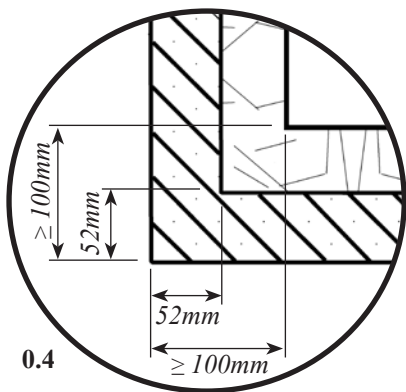
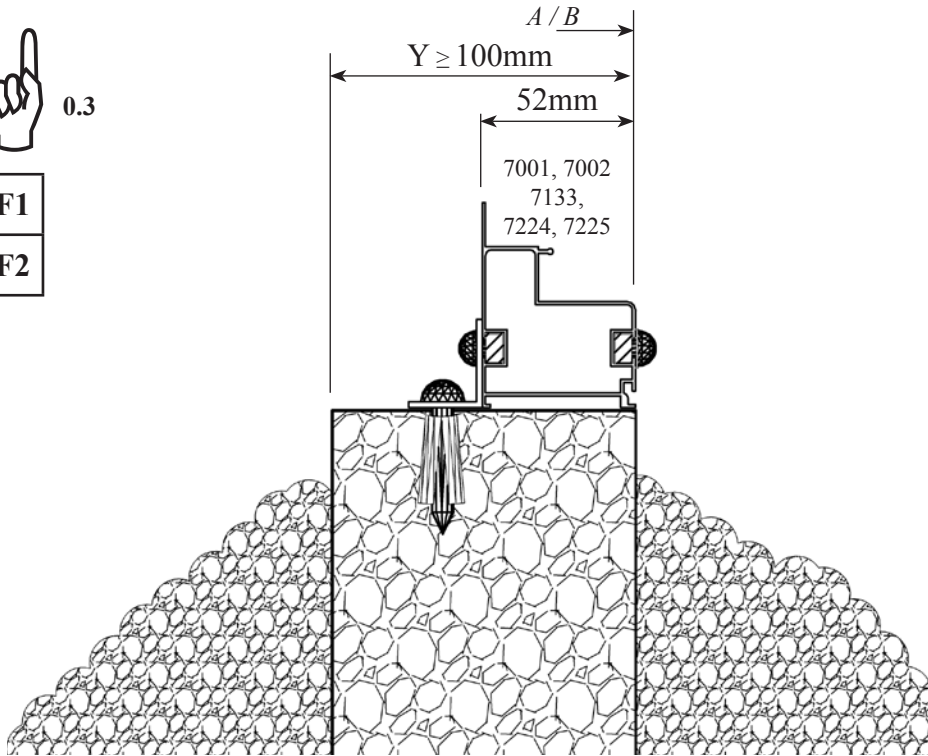
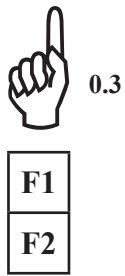

	6200	8100	10000	11900	13800	15700
A	2400 mm	3144 mm	3888 mm	4632 mm	5376 mm	6120 mm
B	2564 mm	2564 mm	2564 mm	2564 mm	2564 mm	2564 mm

Important Tip

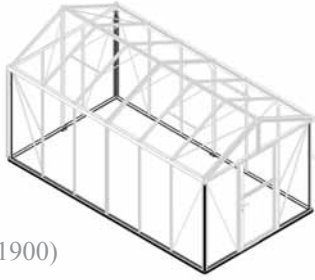

(11900)

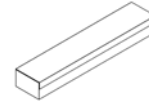
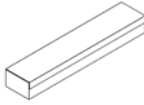

SILL BARS / CORNER POSTS, GRUNDRAHMEN U. ECKPFOSTEN, CADRE DE BASE ET PILIERS D'ANGLE, KALEJES / HOEKPROFIELEN,
 BUNDRAMME OG HJØRNESTOLPER, BOTTENRAM OCH HÖRNSTOLPAR, TERSKELSTENGER / HJØRNESTOLPER, KYNNSTANGOT / KULMAPYLVAÄT,
 TELAIO DI BASE E MONTANTI ANGOLARI, ZÁKLADOVÝ RÁM A ROHOVÉ SLOUPKY, LISTWY PRÓGOWE / SŁUPKI NARÓŻNE,
 OSNOVNI OKVIR IN VOGALNI STEBRI, PÁRKÁNYRUDAK / SAROKOSZLOPOK, PRAGOVI / KUTNI STUPOVI, PRAGOVI / UGAONI STUBOVI,
 BARE DE PERVAZ / STÁLPI DE COLT, PARAPETNÉ LIŠTY / ROHOVÉ STĚPKY, ПОДОКОННЫЕ БРУСЫ / УГЛОВЫЕ СТОЙКИ, ПОРУЧНИ / КУТОВИ СТІЙКИ.

6200	8100	10000	11900	13800	15700	C1
7053						Pack 1/1 - 1/6 ZE2 & Pack 1F & Pack 2 & Pack 3 - 1/2 & Pack 4 - 1/2
8x	8x	8x	8x	8x	8x	
7061						
10x	10x	12x	14x	14x	14x	
7064						
2x	2x	2x	2x	2x	2x	
7080						
40x	40x	48x	56x	56x	56x	
7095						
8x	8x	10x	12x	12x	12x	
7200						
4x	4x	4x	4x	4x	4x	
7399						
8x	8x	8x	8x	8x	8x	
7133						Pack 1/1 - 3/6 ZE2
2x	2x	2x	2x	2x	2x	
7236						Pack 1/1 - 4/6
2x	2x	2x	2x	2x	2x	
7236						Pack 1/1 - 4/6
2x	2x	2x	2x	2x	2x	

6200	8100	10000	11900	13800	15700	C1
7225						Pack 1F
2x	-	-	-	-	-	
7001						Pack 2
2x	4x	2x	-	-	-	
7002						Pack 3 - 2/2
-	-	2x	4x	2x		
7224						Pack 4 - 2/2
-	-	-	-	2x	4x	

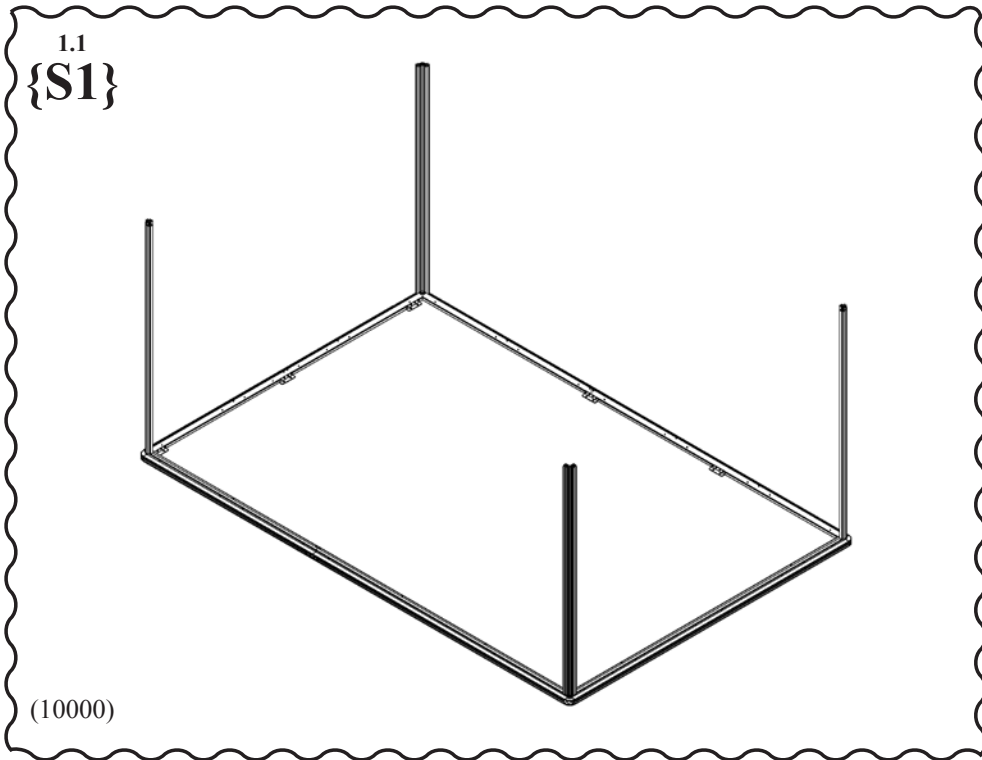

?

1.2.1	SILL 1 - SILL 2 TEIL 1 - TEIL 2 KODE 1 - KODE 2	LENGTH LÄNGE LÆNGDE
6200	7225-7001	776 + 1520 mm
8100	7001-7001	1520 + 1520 mm
10000	7001-7002	1520 + 2264 mm
11900	7002-7002	2264 + 2264 mm
13800	7002-7224	2264 + 3008 mm
15700	7224-7224	3008 + 3008 mm

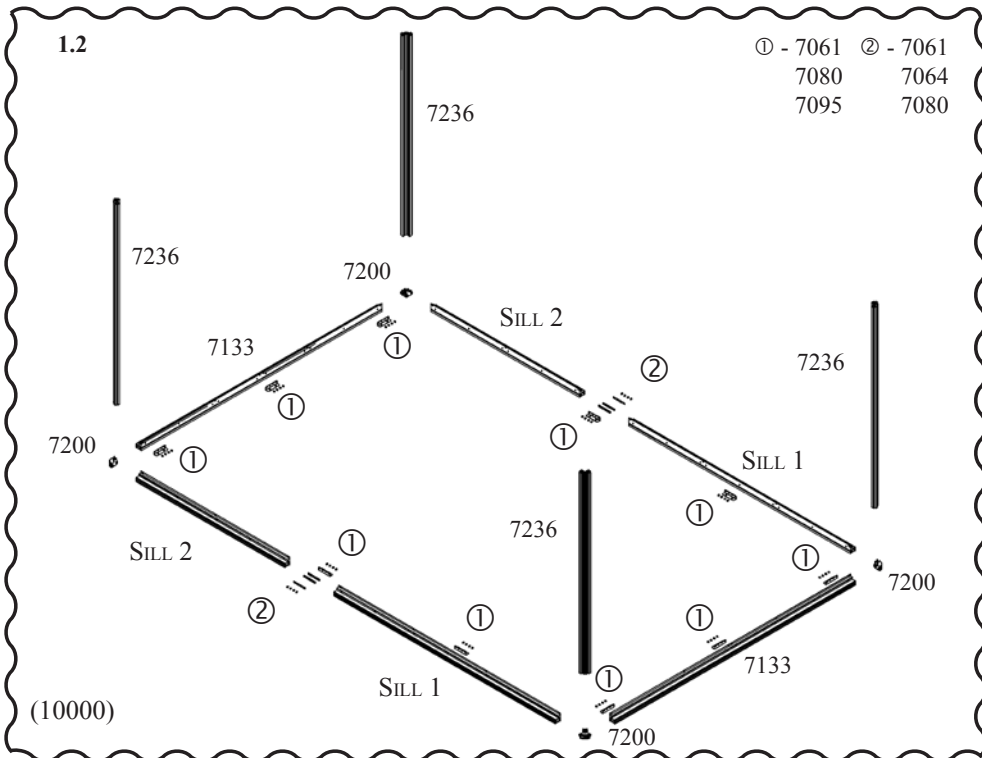

1.2.2	①
6200	8x
8100	8x
10000	10x
11900	12x
13800	12x
15700	12x

Alternative options

1_{A}

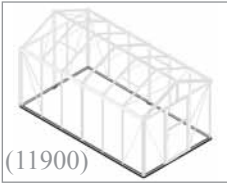

PH2

SILL 1 - SILL 2					
6200	8100	10000	11900	13800	15700
7001					
2x	4x	2x	-	-	-
7002					
-	-	2x	4x	2x	
7224					
-	-	-	-	2x	4x
7225					
2x	-	-	-	-	-

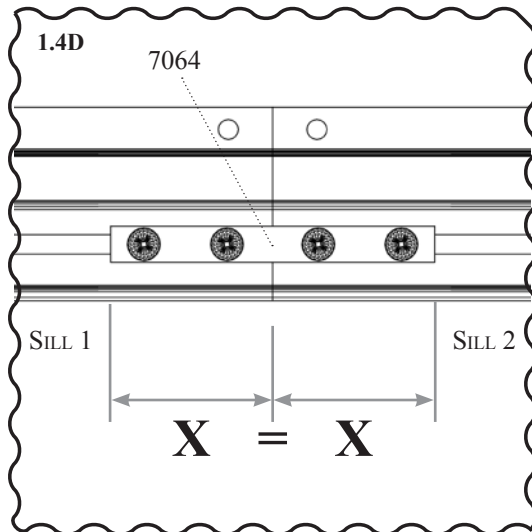
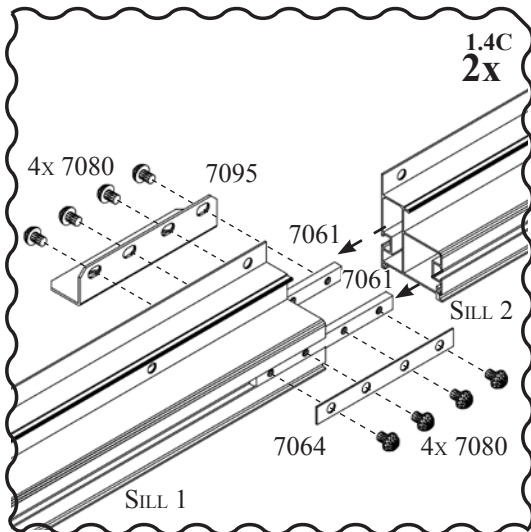
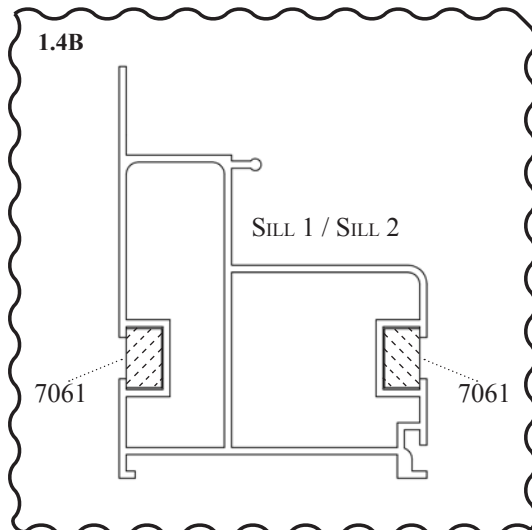
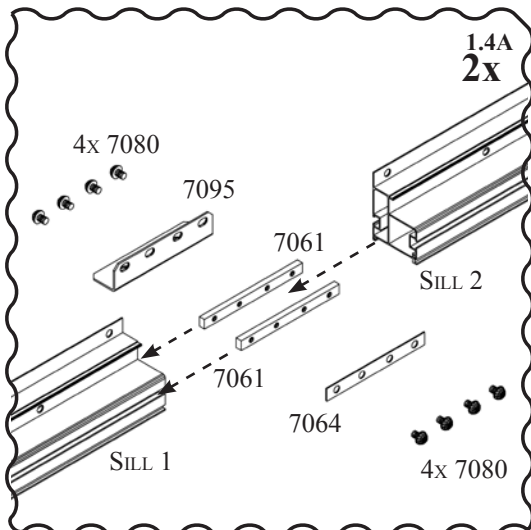
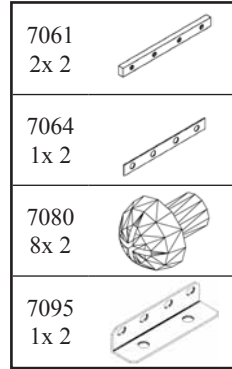
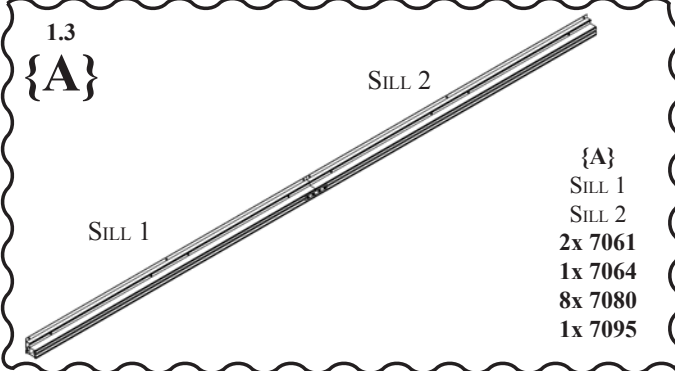

1_{A}

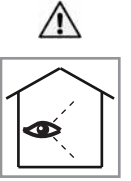
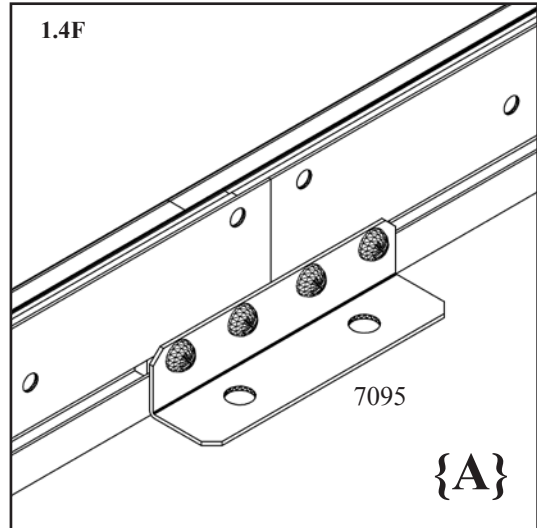
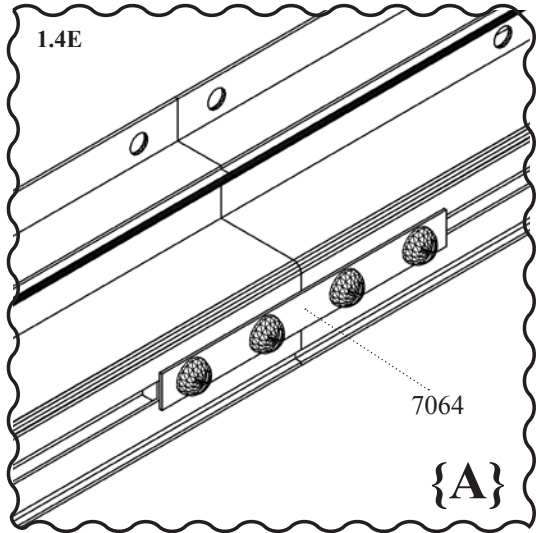

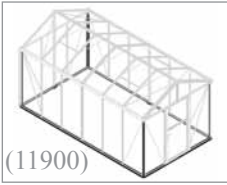

10mm









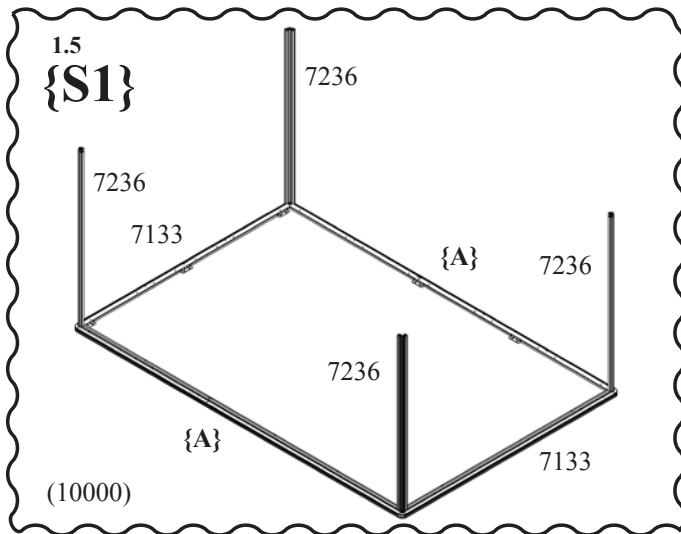

10mm







PH2
FLAT

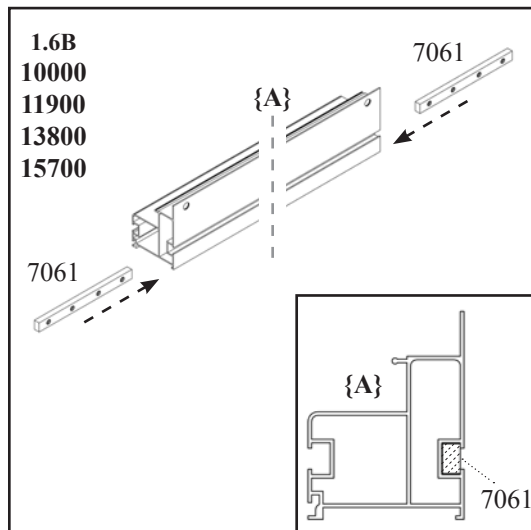
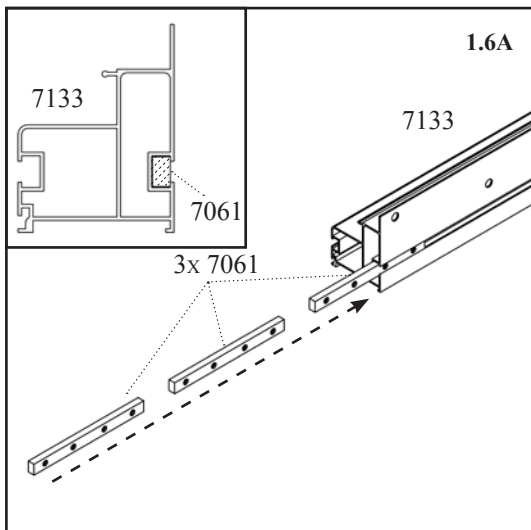

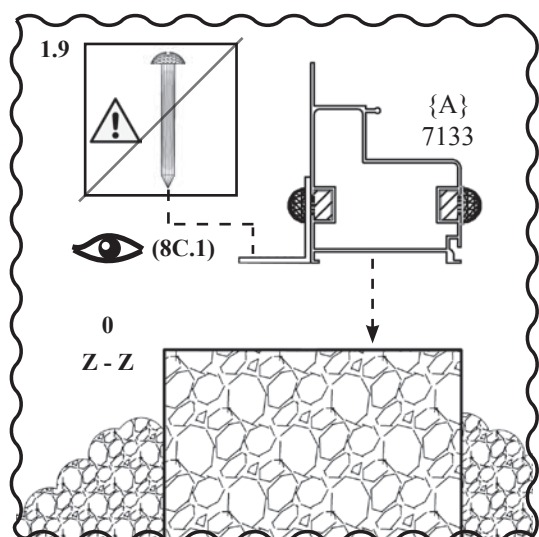
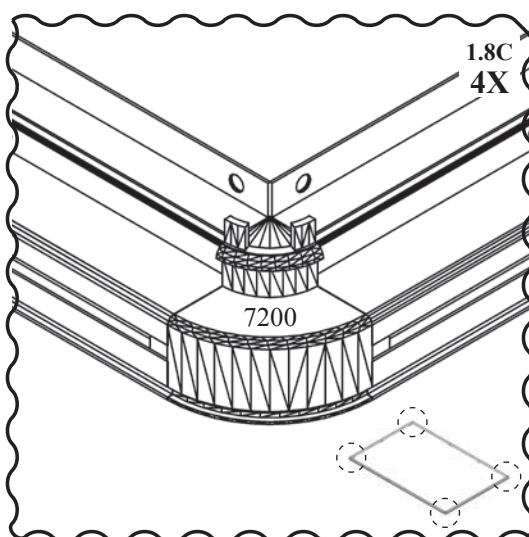
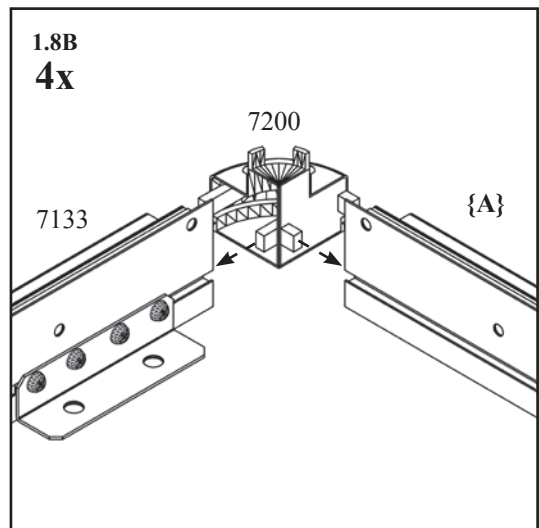
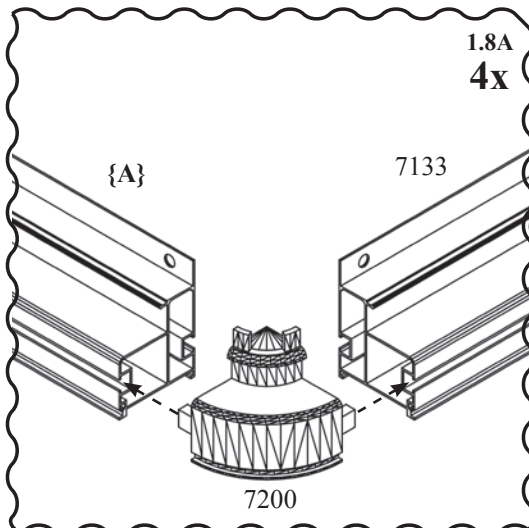
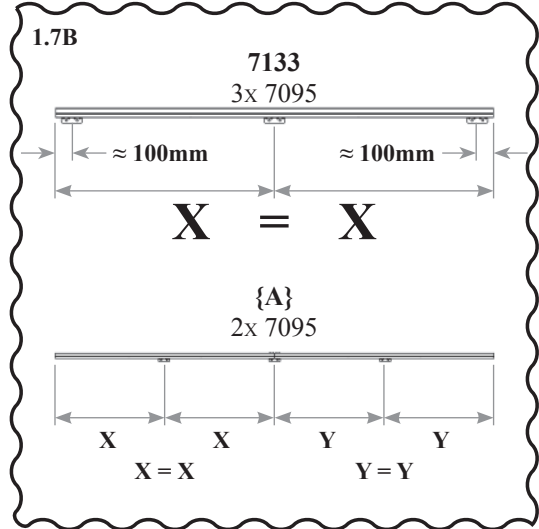
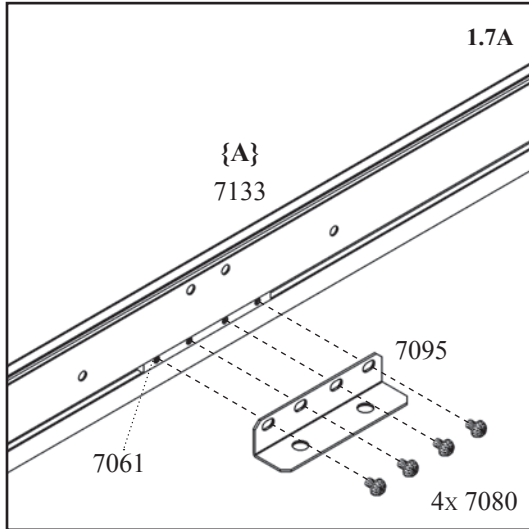
	6200	8100	10000	11900	13800	15700
7053 	8x	8x	8x	8x	8x	8x
7061 	6x	6x	8x	10x	10x	10x
7080 	24x	24x	32x	40x	40x	40x
7095 	6x	6x	8x	10x	10x	10x
7200 	4x	4x	4x	4x	4x	4x
7399 	8x	8x	8x	8x	8x	8x
7133 	2x	2x	2x	2x	2x	2x
7236 	4x	4x	4x	4x	4x	4x
{A} 	2x	2x	2x	2x	2x	2x





 Step for later
  Important!
  Go to
  Important Tip

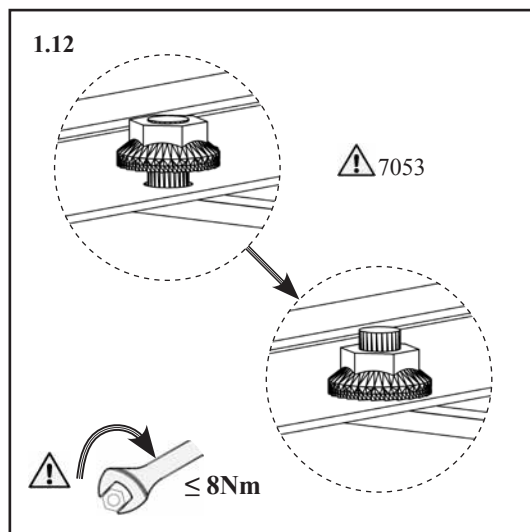
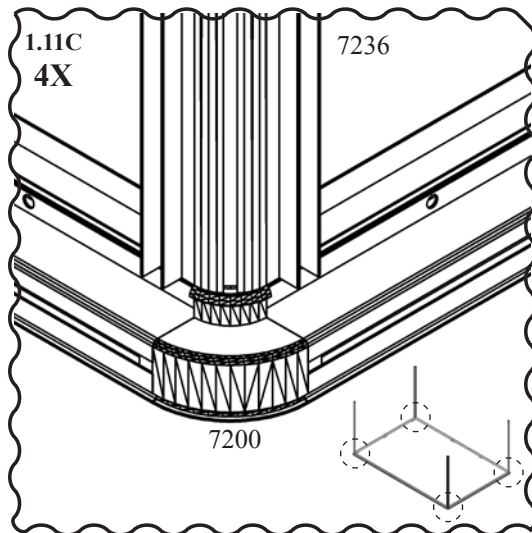
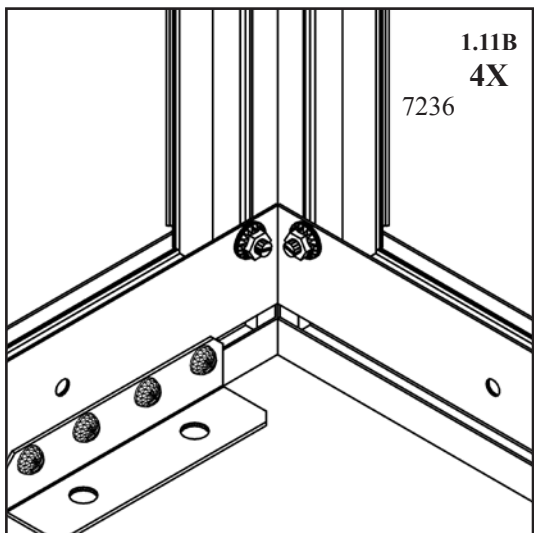
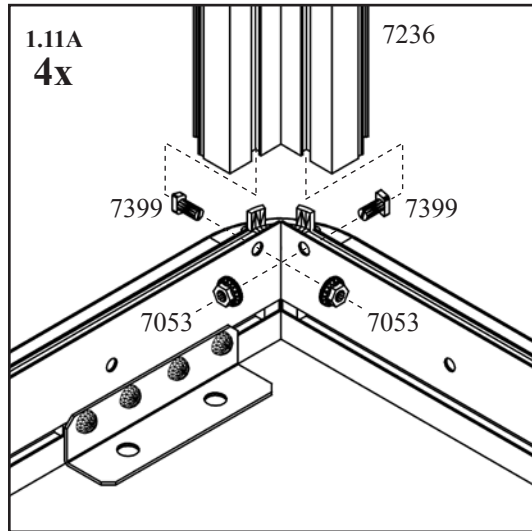
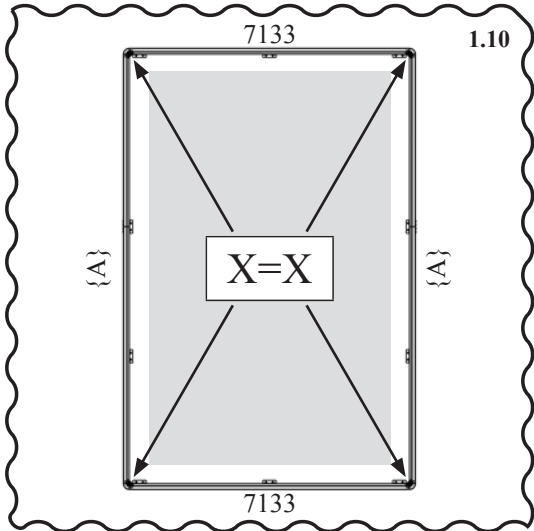

! Important!

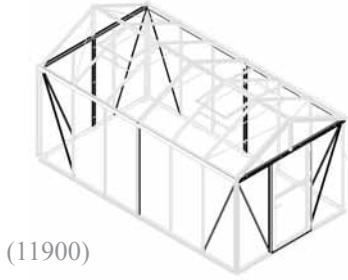

(11900)

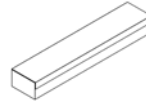
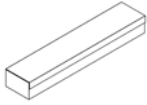

MIDDLE BARS / EAVE ANGLES, ZWISCHENWINKEL, PROFILÉ INTERMÉDIAIRE ET ANGLE DE GOUTTIÈRE, MIDDENPROFIELEN / HOEKEN
 ZUJKANT, MIDTERPROFIL OG TAGREM, MITTBJELKER / TAKFÖTVINKLER, KESKIPALKIT / RÄYSTÄSKULMAT, PROFILO INTERMEDIO
 E ANGOLARE DELLA GRONDA, MEZIPROFILY / OKAPOVÝ ÚHEL, ŠRODKOWE PRĘTY / KĄTY OKAPU, VMESNI PROFIL IN KAPNI KOTNIKI, KÓZÉPSÓ RUDAK /
 ERESZSZÓGÉK, SREDNJE PRÉČKE / KUTOVI STREHE, SREDNJE PRÉČKE / KUTOVI STREHE, BARE DE MILLOC / UNGHIURI LA STREAȘINĂ, STREDOVÉ TYČE /
 ODKVAROVÉ UHLX, СРЕДНИЕ ПЛАНКИ / УГЛЫ СВЕСА, СЕРЕДНІ ПЛАНКИ / КАРНИЗНІ КУТИ.

6200	8100	10000	11900	13800	15700	Σ
7052	32x					Pack 1/1 - 1/6 ZE2
7053	36x					
7390	4x					
7029	1x					Pack 1/1 - 2/6 ZE2
7045	1x					Pack 1/1 - 2/6 ZE2
7036	1x					Pack 1/1 - 3/6 ZE2
7069	2x					Pack 1/1 - 3/6 ZE2
7134	2x					
7006	3x					Pack 1/1 - 4/6
7069	2x					
7269	4x					

6200	8100	10000	11900	13800	15700	Σ
7221						Pack 1F
1x	-	-	-	-	-	
7222						Pack 1F
1x	-	-	-	-	-	
7201						Pack 2
1x	2x	1x	-	-	-	
7202						Pack 2
1x	2x	1x	-	-	-	
7203						Pack 3 - 2/2
-	-	1x	2x	1x	-	
7204						Pack 3 - 2/2
-	-	1x	2x	1x	-	
7205						Pack 4 - 2/2
-	-	-	-	1x	2x	
7206						Pack 4 - 2/2
-	-	-	-	1x	2x	

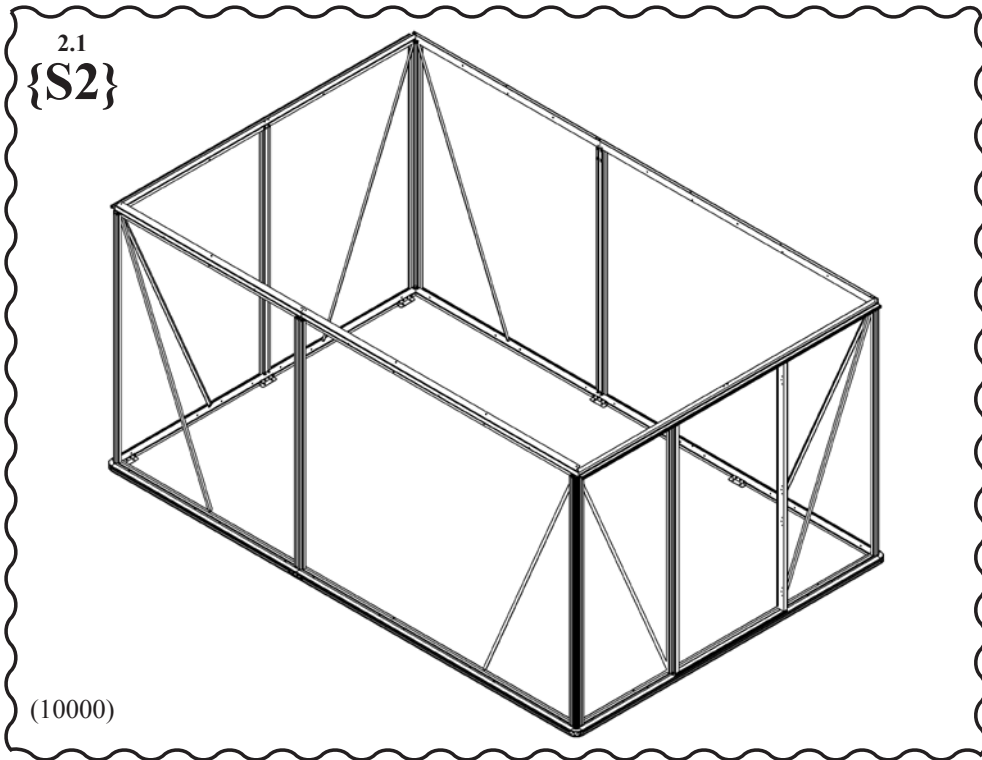

2.2.1	EAVE 1-2-3-4 TEIL 1-2-3-4 TAGREM 1-2-3-4	LENGTH (1 / 2 + 3 / 4) LÄNGE (1 / 2 + 3 / 4) LÆNGDE (1 / 2 + 3 / 4)
6200	7221-7222-7201-7202	795 + 1539 mm
8100	7201-7202-7201-7202	1539 + 1539 mm
10000	7201-7202-7203-7204	1539 + 2283 mm
11900	7203-7204-7203-7204	2283 + 2283 mm
13800	7203-7204-7205-7206	2283 + 3027 mm
15700	7205-7206-7205-7206	3027 + 3027 mm

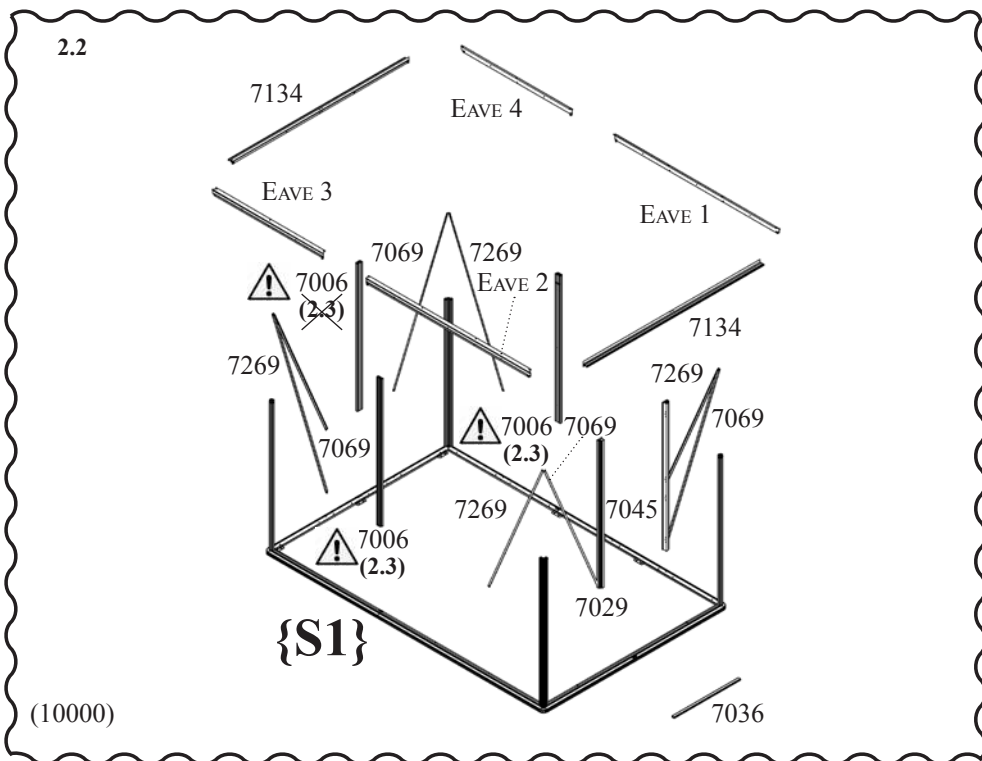

Alternative options



Important!

2

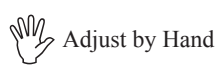
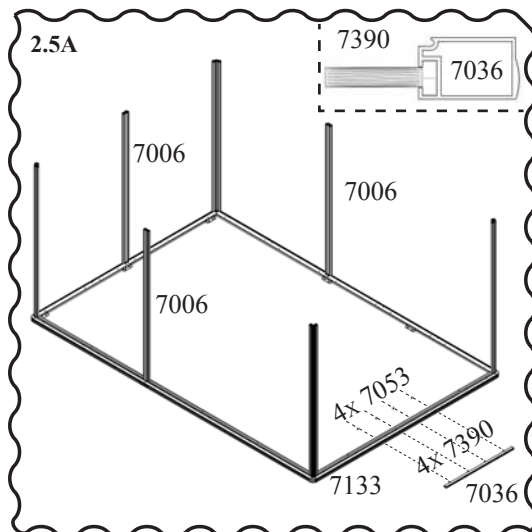
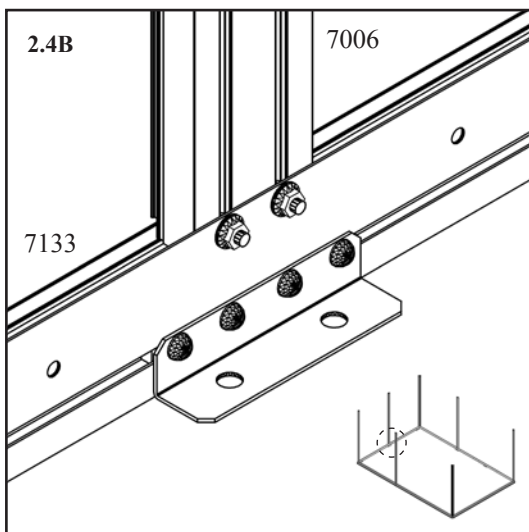
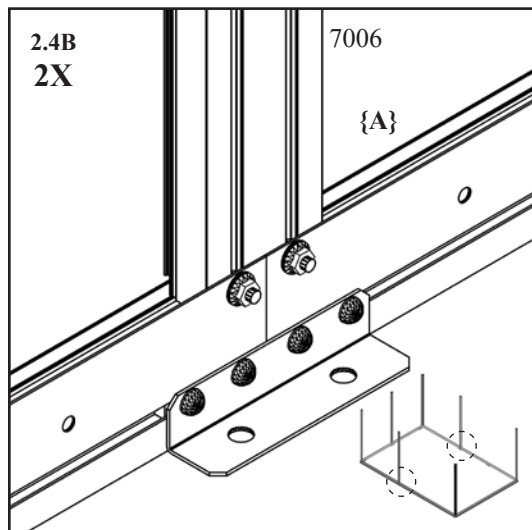
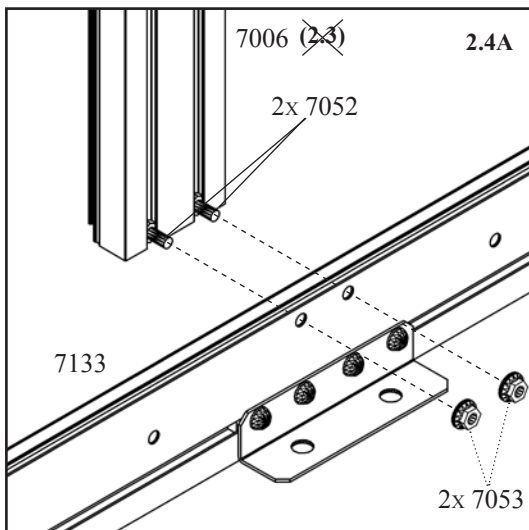
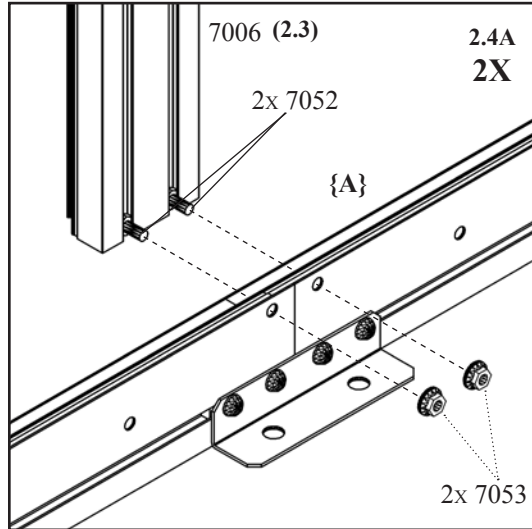
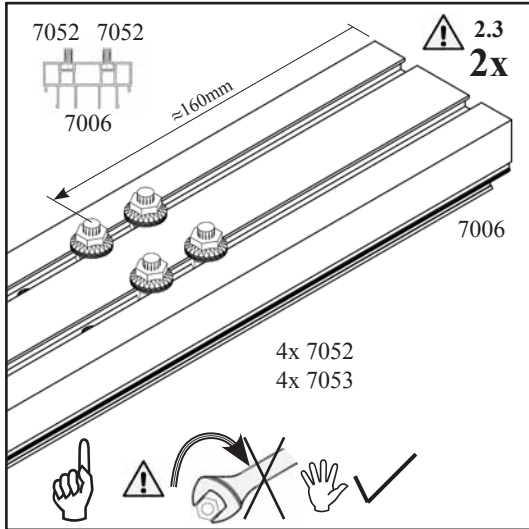

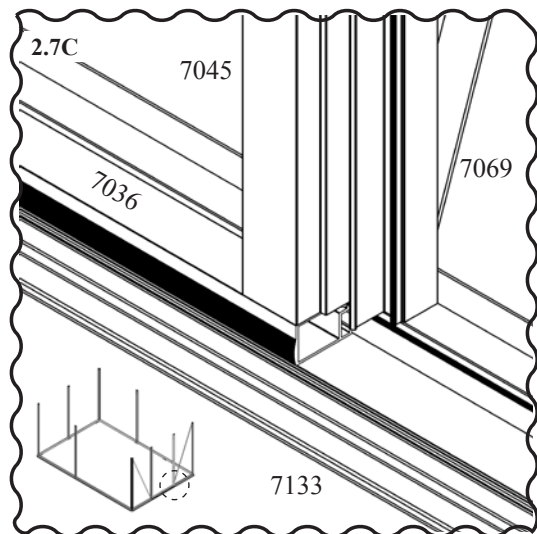
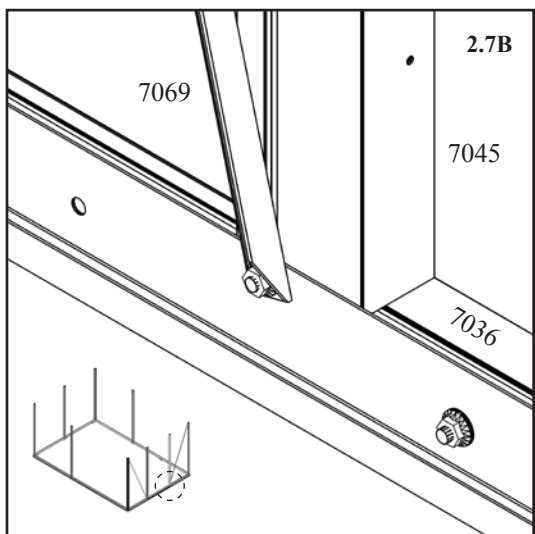
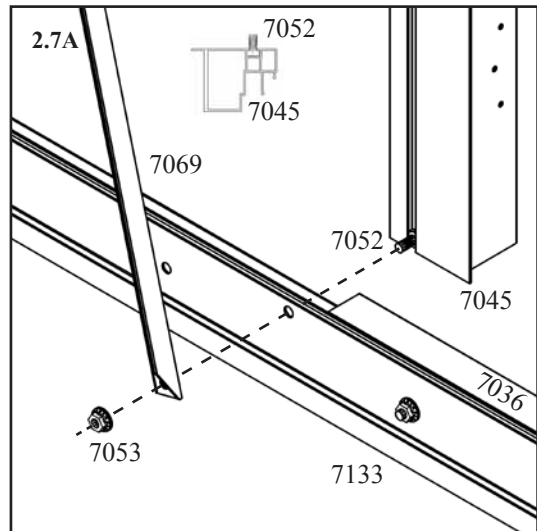
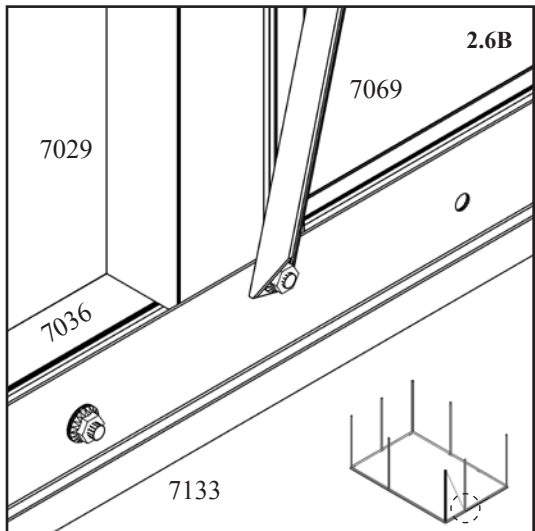
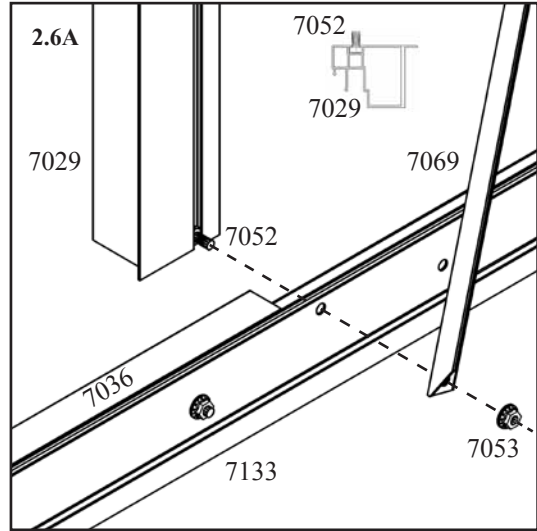
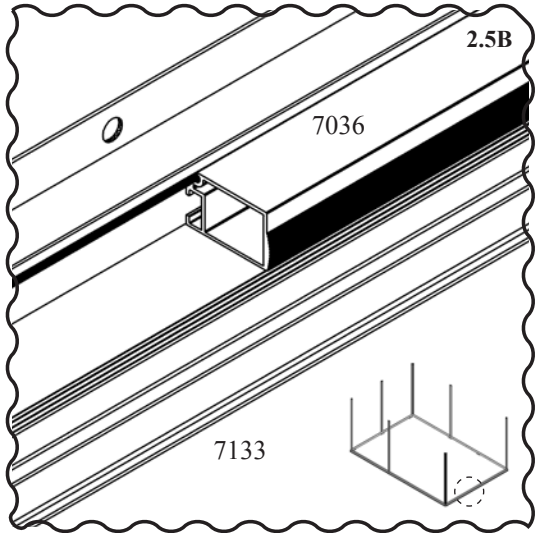

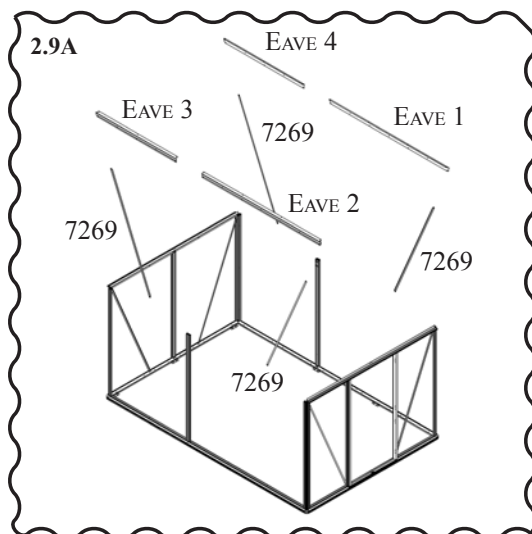
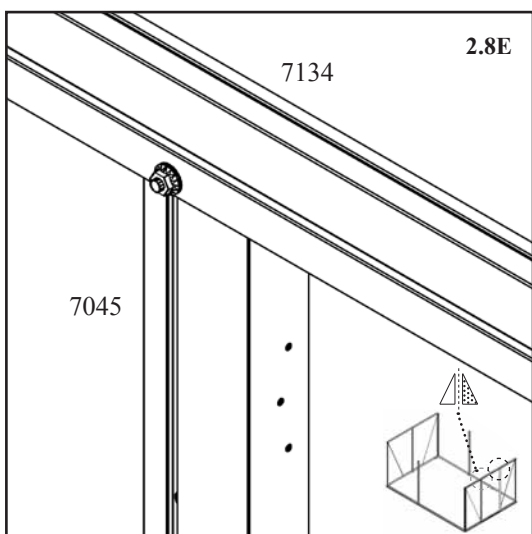
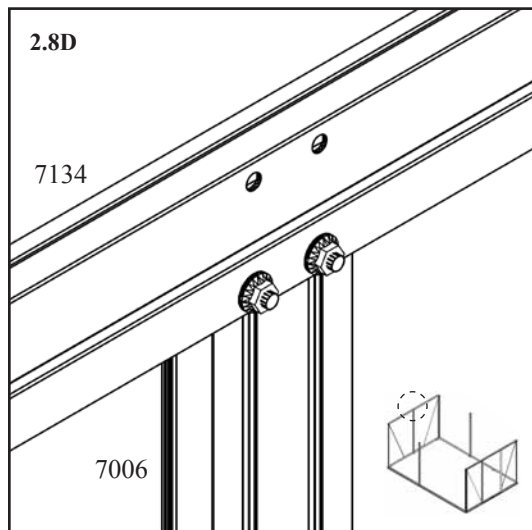
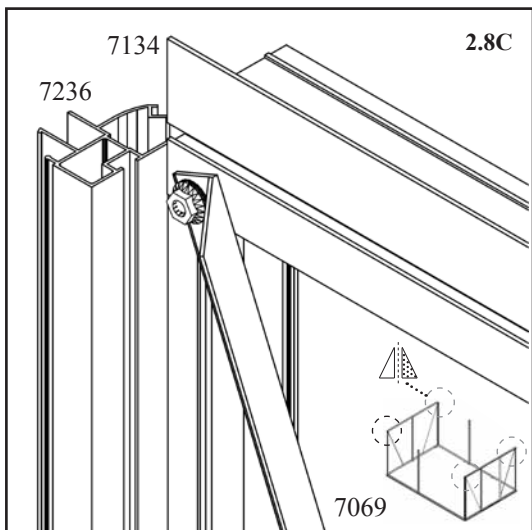
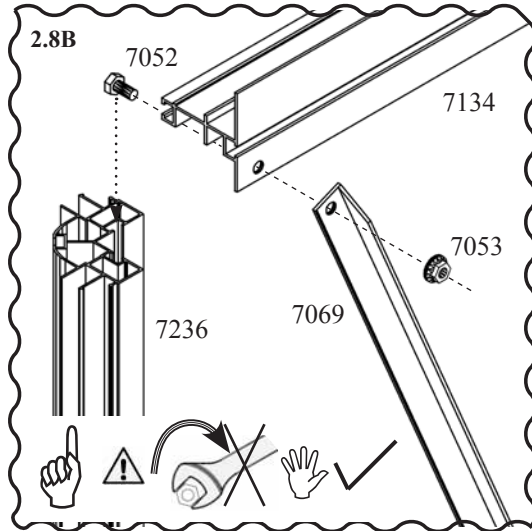
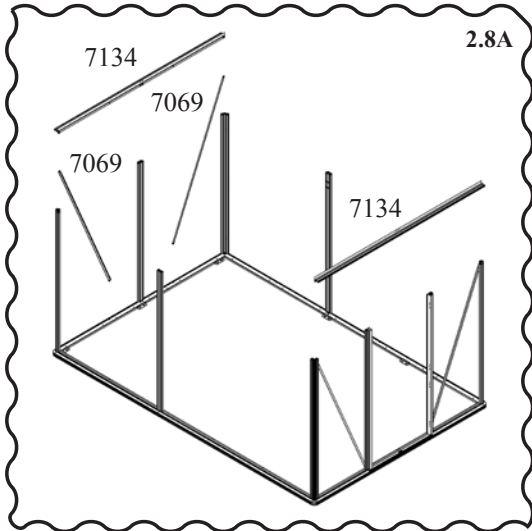

 Important Tip
  Important!
  Adjust by Hand
  Mirror of

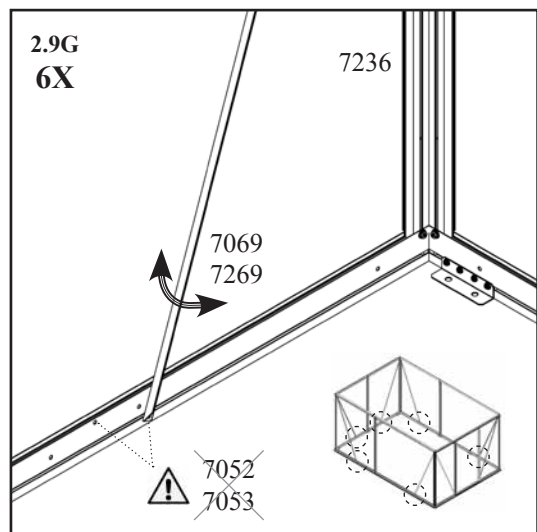
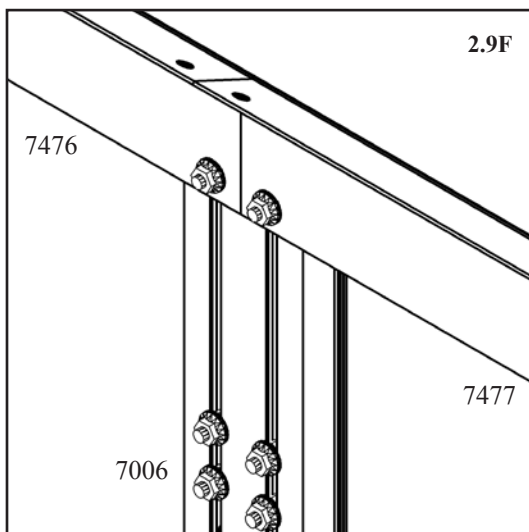
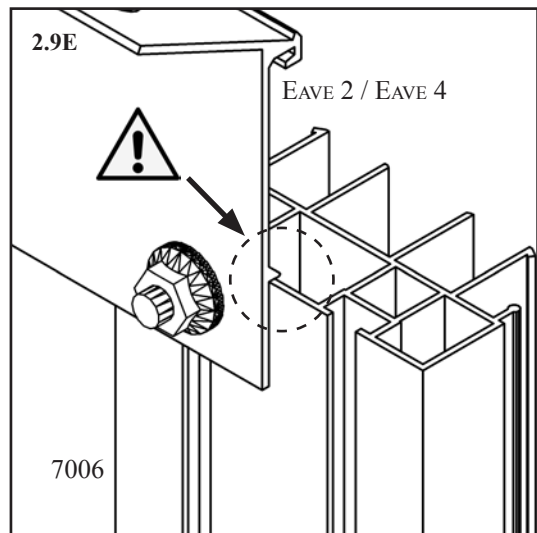
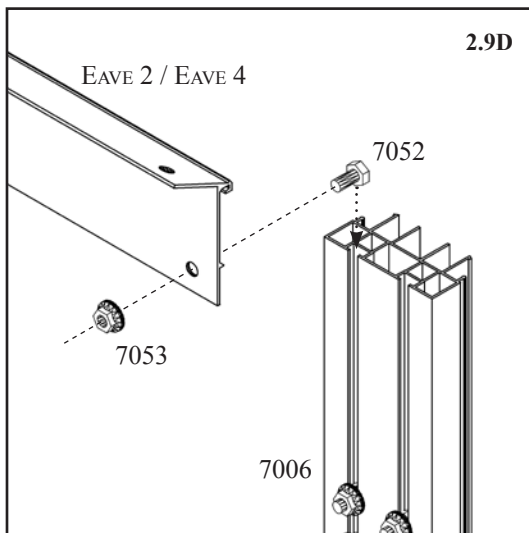
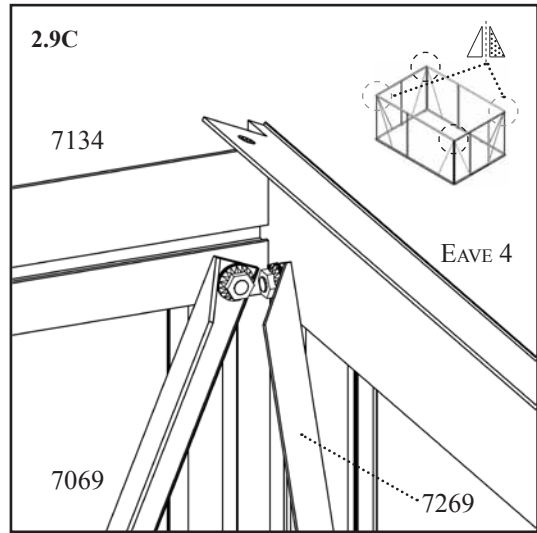
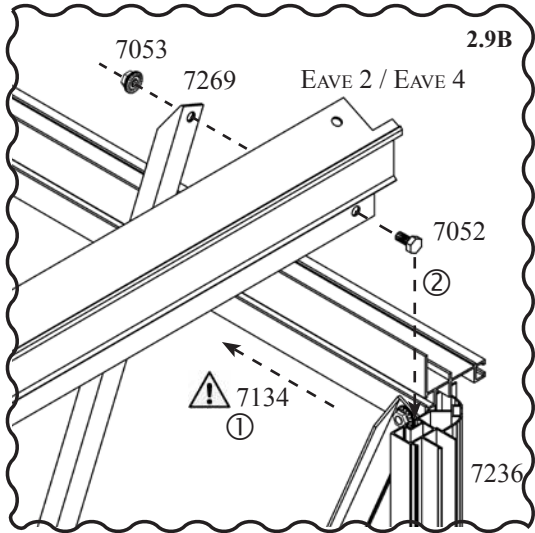

Important! Mirror of

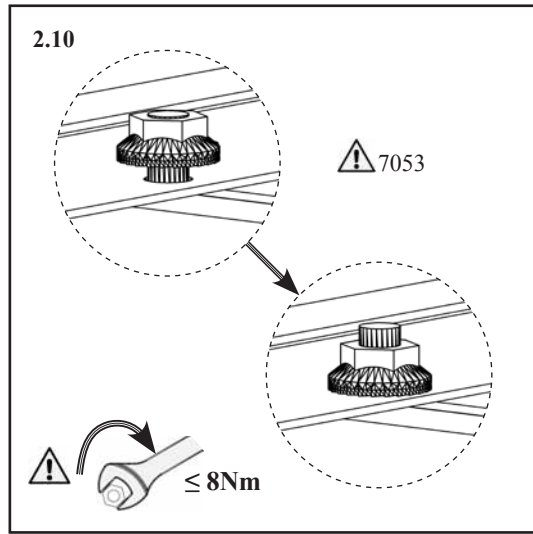

! Important!

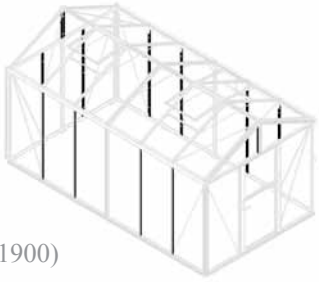

(11900)

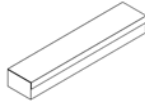

MIDDLE BARS, ZWISCHENPROFIL, PROFILÉ INTERMÉDIAIRE, MIDDENPROFIELEN, MELEMPROFILER, MELLANPROFILER, MIDTBELKER, KESKIPALKIT, PROFILI INTERMEDI, MEZIPROFLY, ŠRODKOWE PRĘTY, VĚSNÍ PROFIL, KŐZÉPSŐ RUDAK, SREDNJE PREČKE, SREDNJE PREČKE, BARE DE MIJLOC, STREDOVÉ TYČE, СРЕДНИЕ ПЛАНКИ, СЕРЕДНІ ПЛАНКИ.

6200	8100	10000	11900	13800	15700	Г3
7052						Pack 1/1 - 1/6 ZE2
20x	28x	36x	44x	52x	60x	
7053						Pack 1/1 - 4/6
16x	24x	32x	40x	48x	56x	
7005						Pack 1/1 - 5/6
2x	2x	2x	2x	2x	2x	
7219						Pack 1/2
2x	2x	2x	2x	2x	2x	
7005						Pack 1F
-	4x	4x	4x	8x	12x	
7005						Pack 3 - 1/2
2x	-	-	-	-	-	
7005						Pack 3 - 1/2
-	-	2x	4x	2x	-	

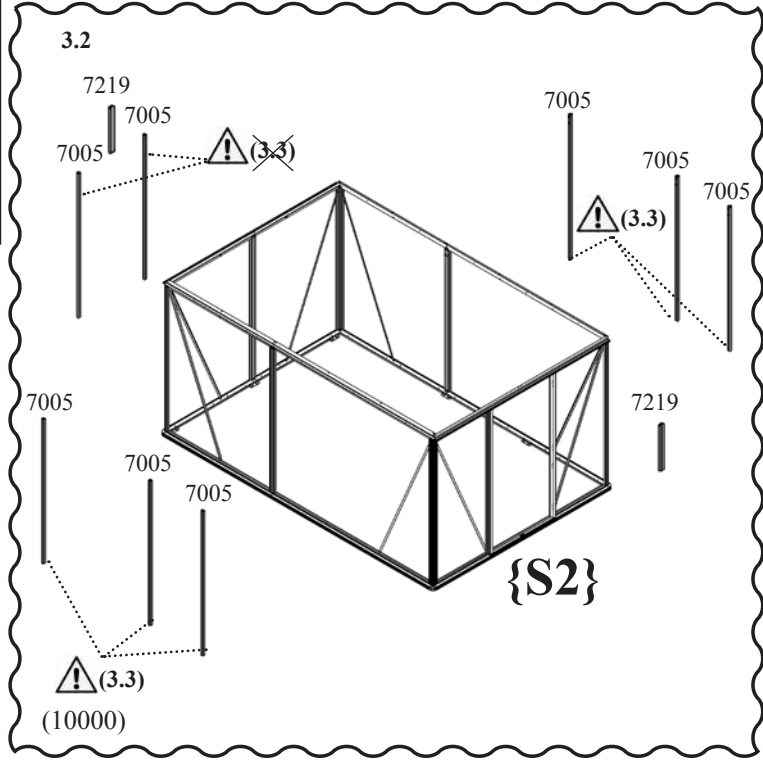
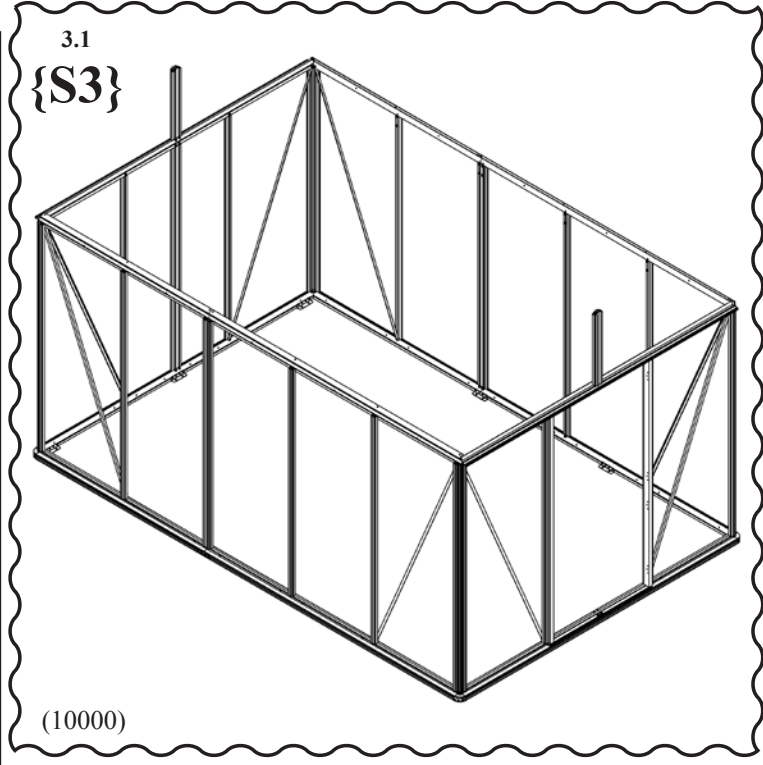

Important!

3



7052
7005
2x 7052
2x 7053
3.3
≈160mm
7005

⚠	7005 + 2x 7052 2x 7053	6200	8100	10000	11900	13800	15700
		2x	4x	6x	8x	10x	12x

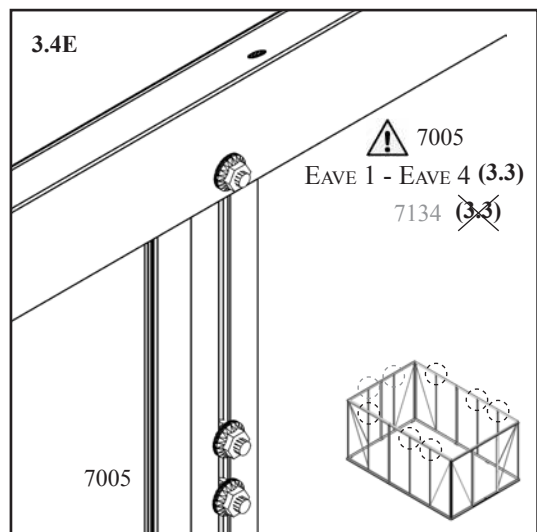
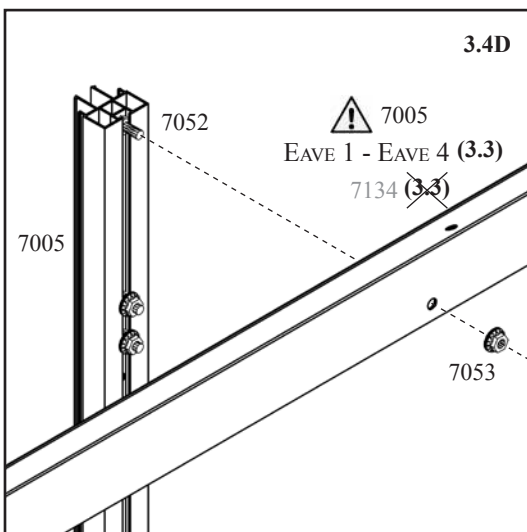
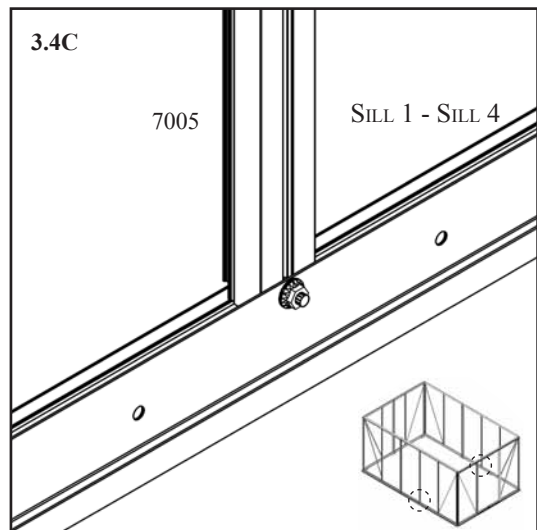
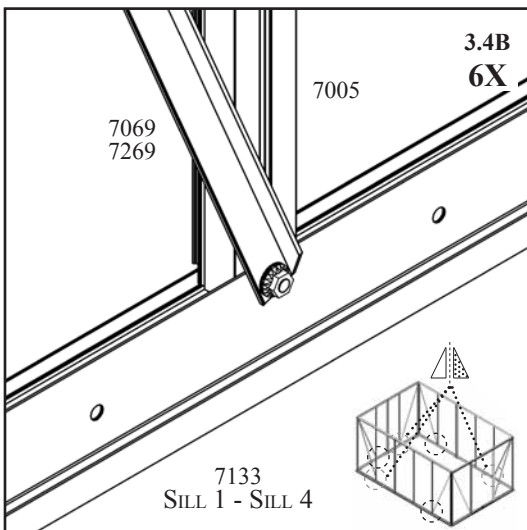
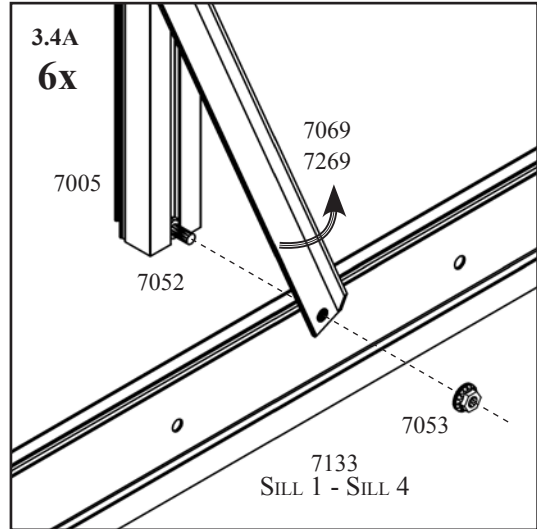

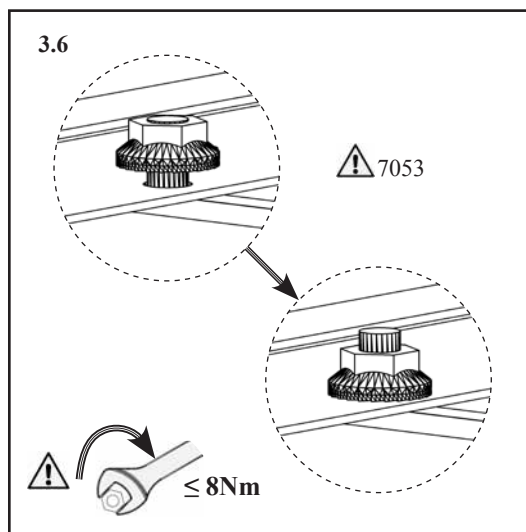
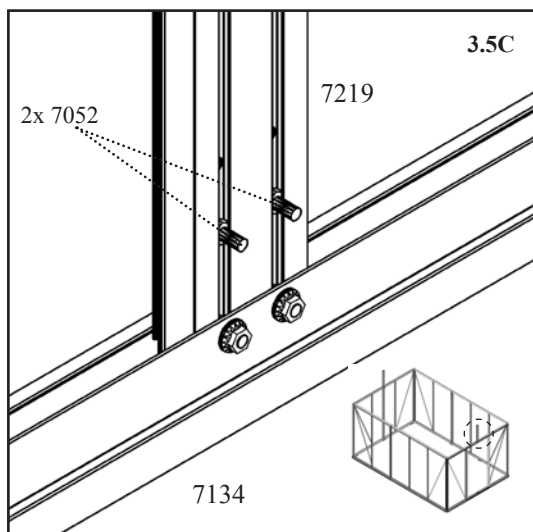
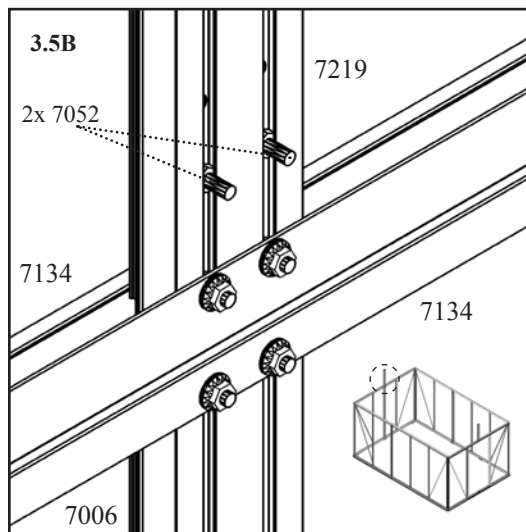
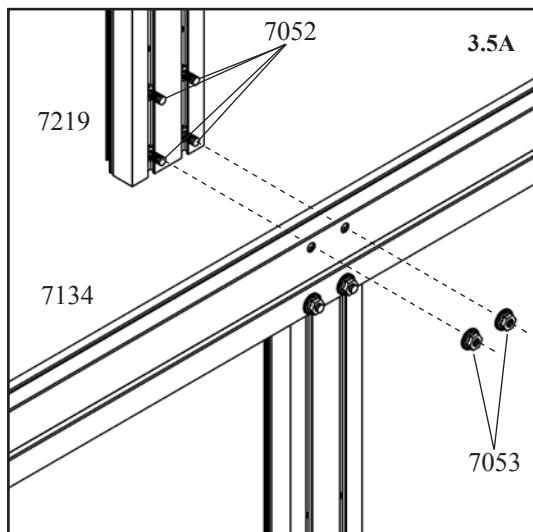

 Important!

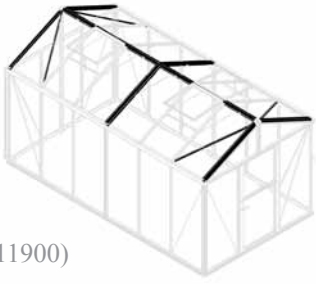

(11900)

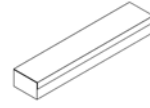
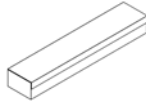

ROOF, DACH, ТОПТ, ДАК, ТАГ, ТАК, КАГТО, ТЕТТО, СТРЕСНА,
 DACH, STREHA, ТЕТÓ, КРОВ, АСОРЕПИС, STRECHA, КРЫША, ДАХ.

6200	8100	10000	11900	13800	15700	C4A			
7052 40x						Pack 1/1 - 1/6 ZE2 & Pack 2 & Pack 3 - 1/2 & Pack 4 - 1/2			
7053 44x									
7061 1x									
7062 4x									
7064 1x									
7065 2x									
7080 4x									
7081 4x									
7295 4x		Pack 1/1 - 4/6							
7237 2x		Pack 1/1 - 5/6							
7238 2x									
7256 2x									

6200	8100	10000	11900	13800	15700	C4A
7253						Pack 1F
1x	-	-	-	-	-	
7260						
2x	-	-	-	-	-	
7250						Pack 2
1x	2x	1x	-	-	-	
7257						
2x	4x	2x	-	-	-	
7251						Pack 3 - 2/2
-	-	1x	2x	1x	-	
7258						
-	-	2x	4x	2x	-	
7252						Pack 4 - 2/2
-	-	-	-	1x	2x	
7259						
-	-	-	-	2x	4x	

4A

4A.1
{S4A}

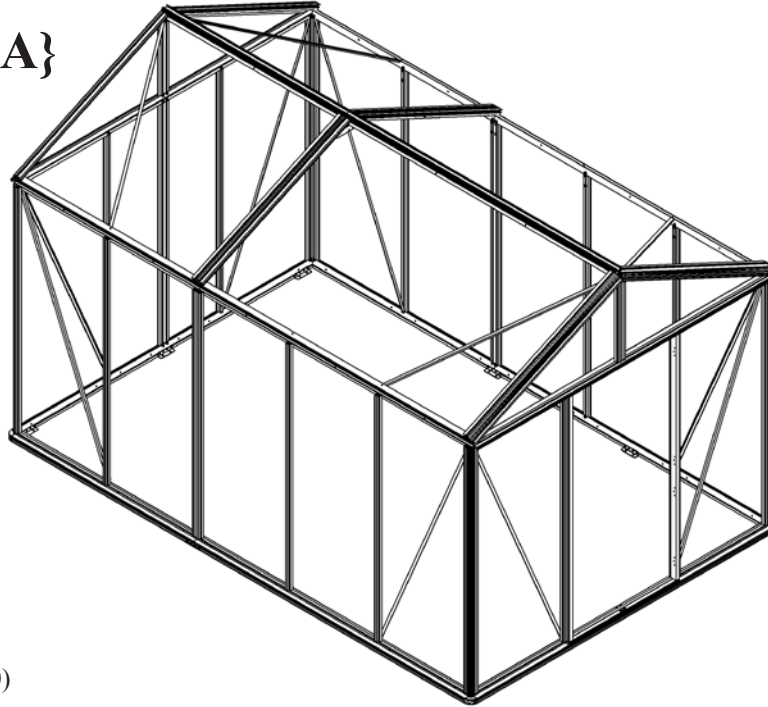

(10000)

4.2.1	RIDGE 1 - RIDGE 2 TEIL 1 - TEIL 2 TAGRYG 1 – TAGRYG 2	LENGTH LÄNGE LÆNGDE
6200	7253 - 7250	776 + 1520 mm
8100	7250 - 7250	1520 + 1520 mm
10000	7250 - 7251	1520 + 2264 mm
11900	7251 - 7251	2264 + 2264 mm
13800	7251 - 7252	2264 + 3008 mm
15700	7252 - 7252	3008 + 3008 mm

?

4A.2

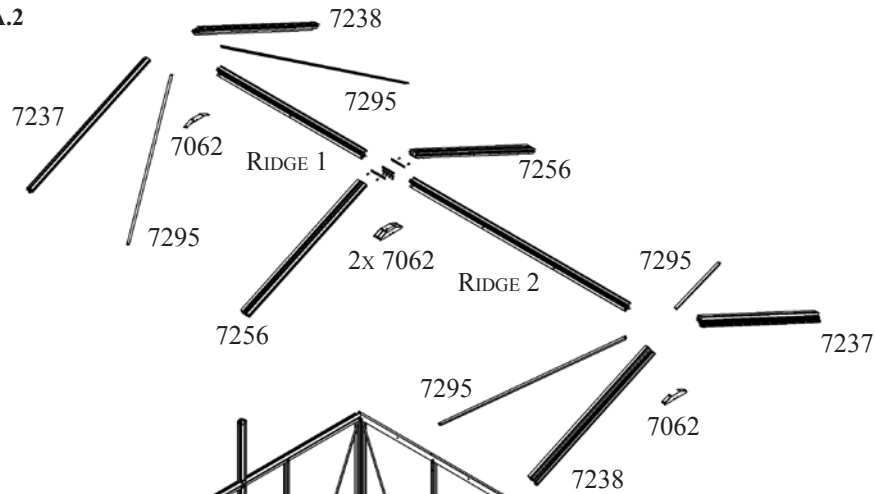

{S3}

(10000)

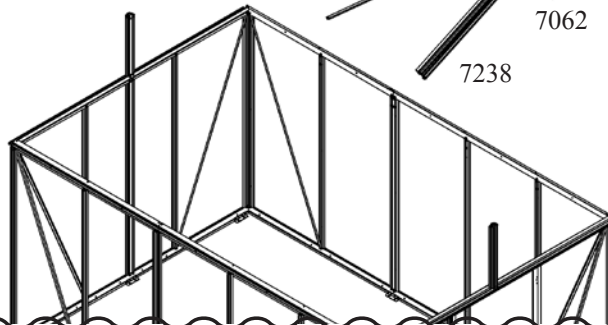

Alternative options

4A {B}

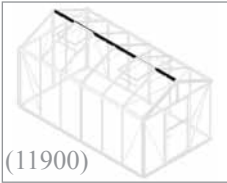

(11900)



PH2

RIDGE 1 - RIDGE 2						
6200	8100	10000	11900	13800	15700	
7250 2x 7257						
1x	2x	1x	-	-	-	-
7251 2x 7258						
-	-	1x	2x	1x	-	-
7252 2x 7259						
-	-	-	-	1x	2x	-
7253 2x 7260						
1x	-	-	-	-	-	-

4A.3
{B}

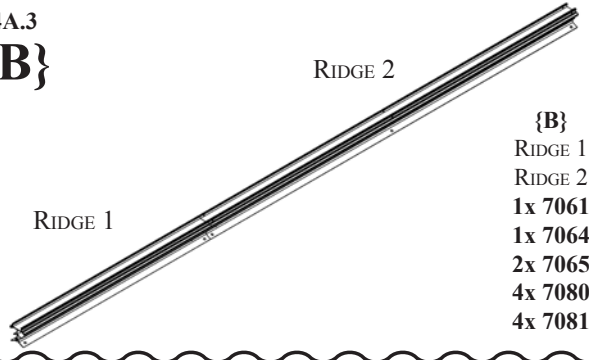

- {B}**
- RIDGE 1
- RIDGE 2
- 1x 7061
- 1x 7064
- 2x 7065
- 4x 7080
- 4x 7081

- 7061
1x
- 7064
1x
- 7065
2x
- 7080
4x
- 7081
4x

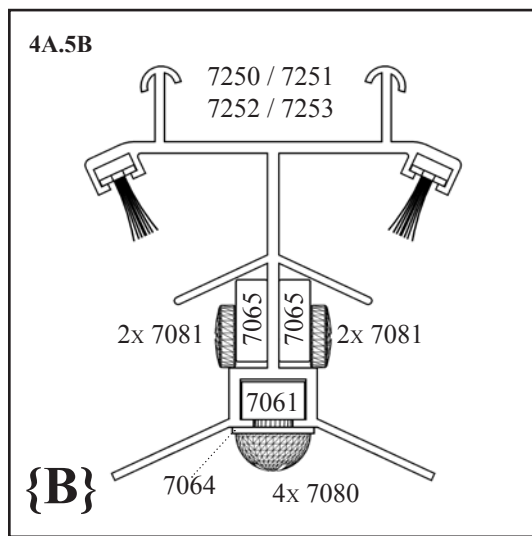
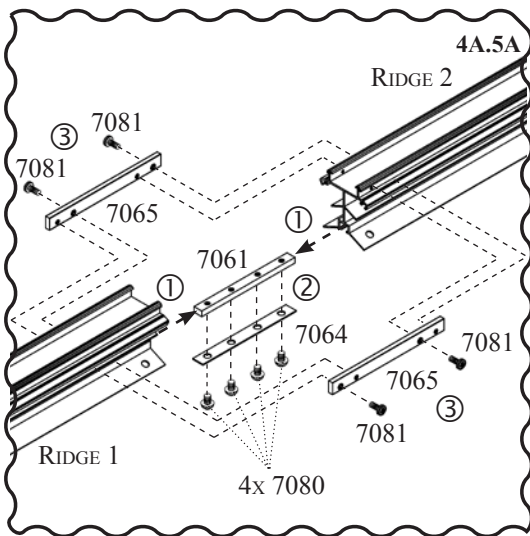
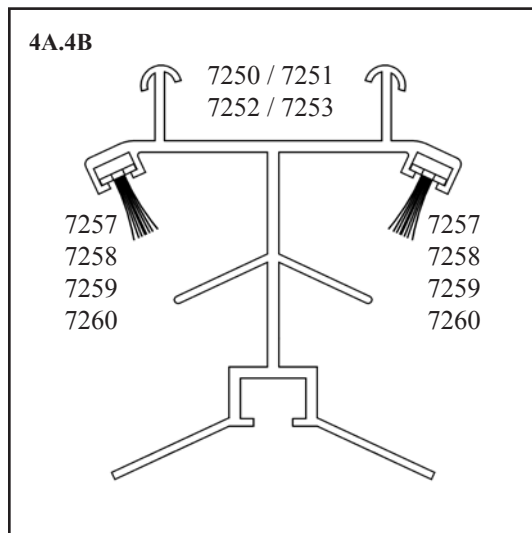
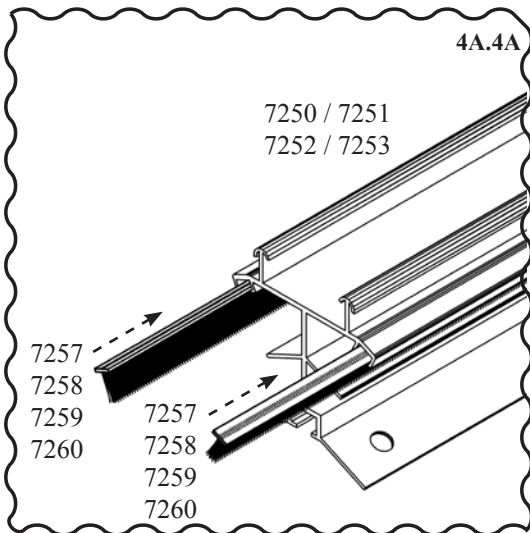

4A

(11900)

10mm 10mm

②

②

7052 40x	
7053 44x	
7062 4x	
7237 2x	
7238 2x	
7256 2x	
7295 4x	

4A.6

{S4A}

8x 7052

7256

4A.7A

4x 7052
4x 7053

≈185mm

7256

7256

⚠ (4A.7B)

7256

4A.7B

⚠

⚠ (4A.12C)

7256

4x 7052
4x 7053

4A.7C

≈185mm

7256

7256

7256

3x 7052

7237
7238

4A.8A

3x 7052
3x 7053

≈185mm

7237
7238

7237
7238

Important!
 Go to
 Important Tip
 Adjust by Hand

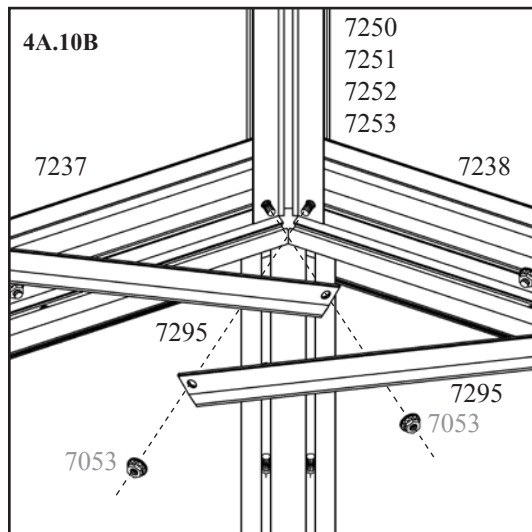
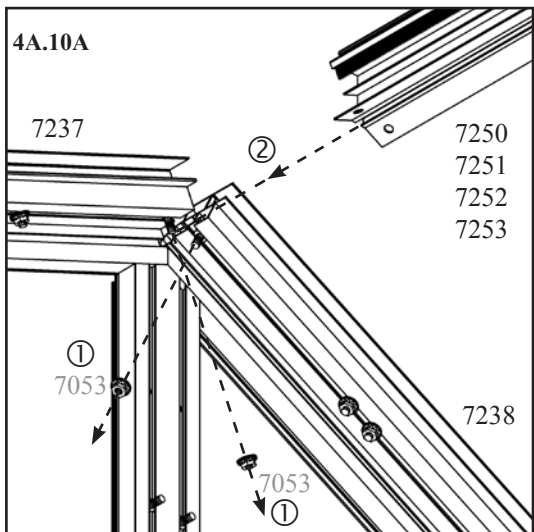
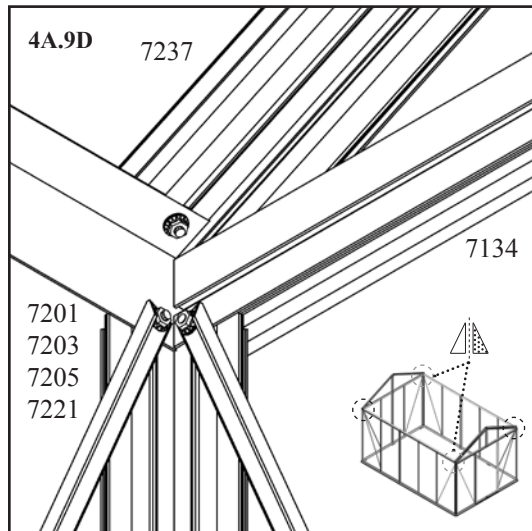
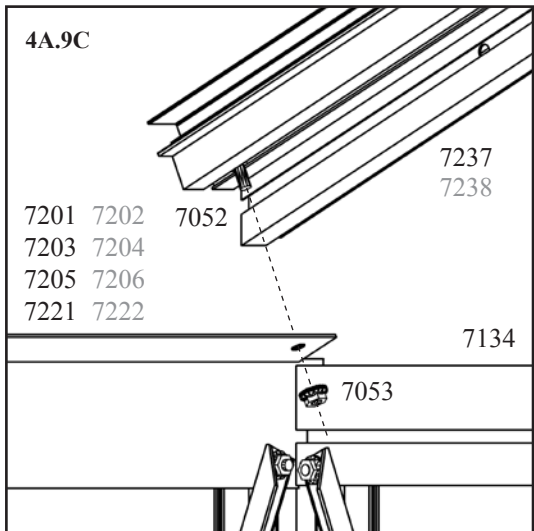
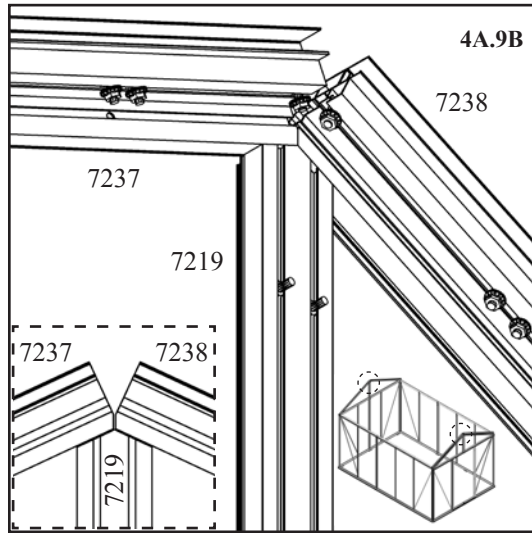
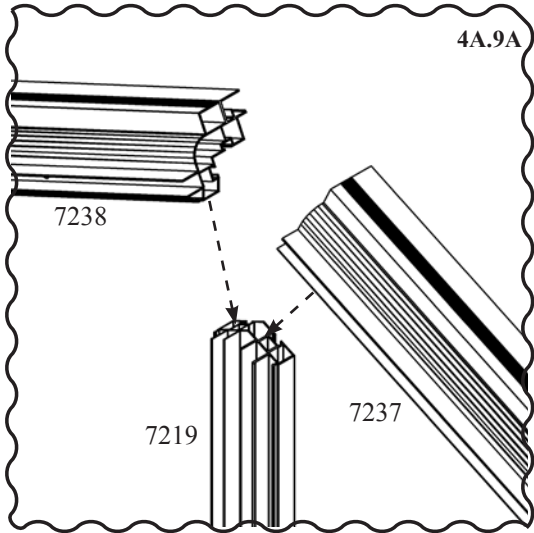

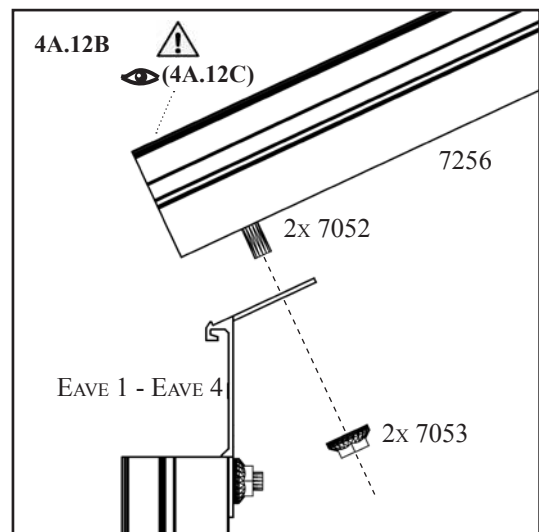
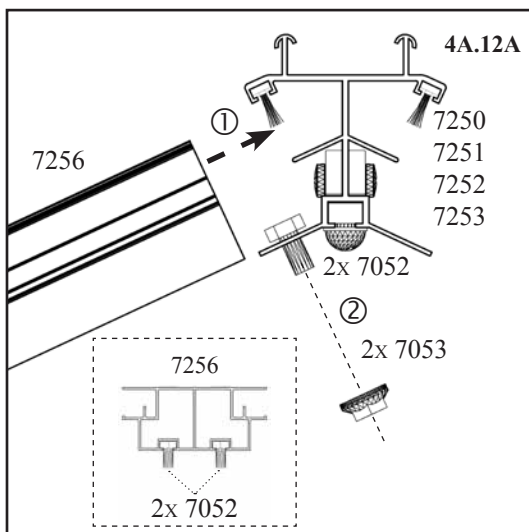
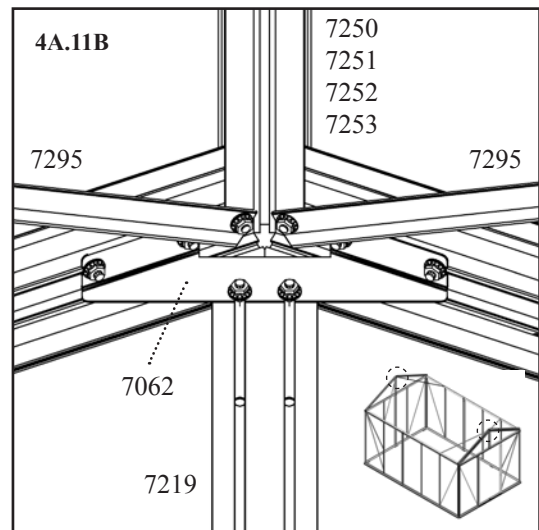
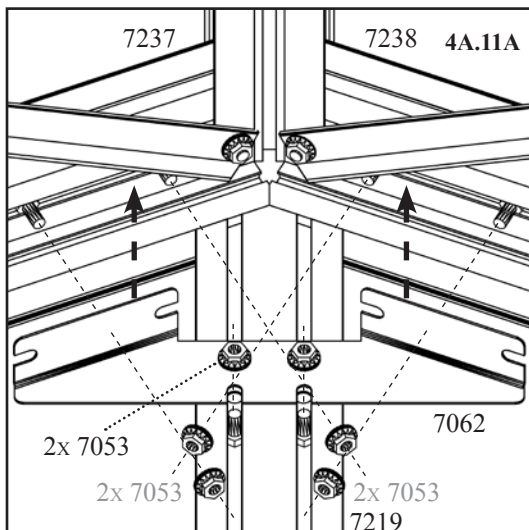
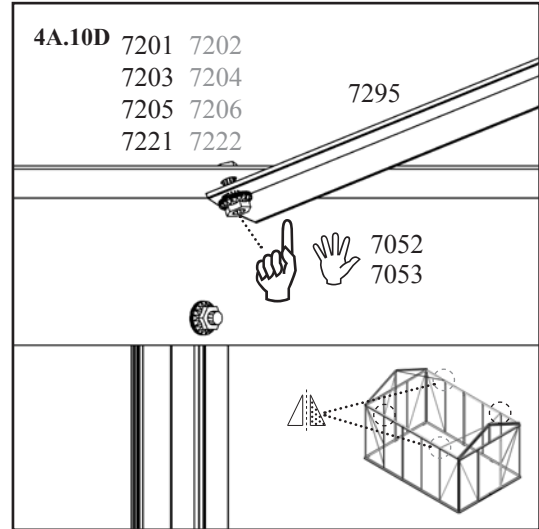
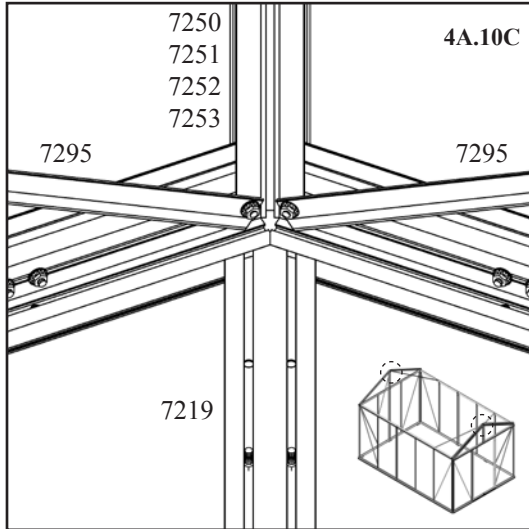

 Mirror of

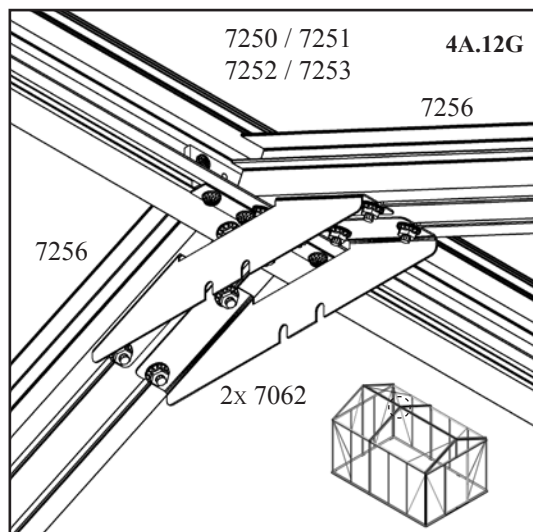
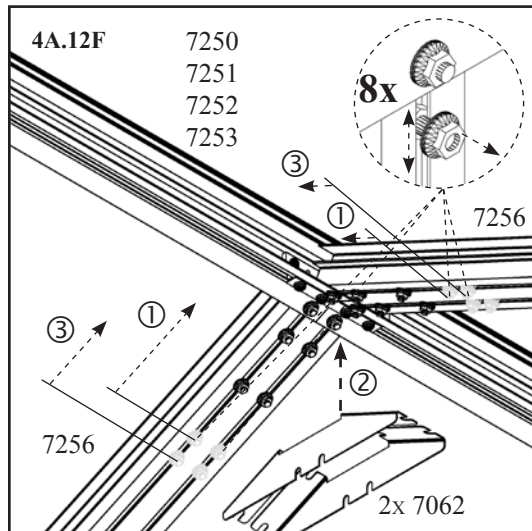
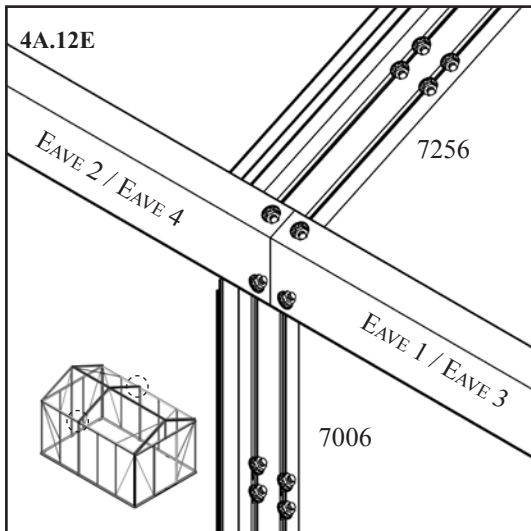
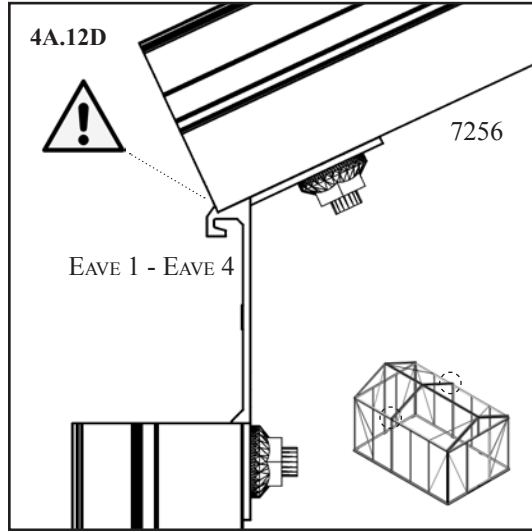
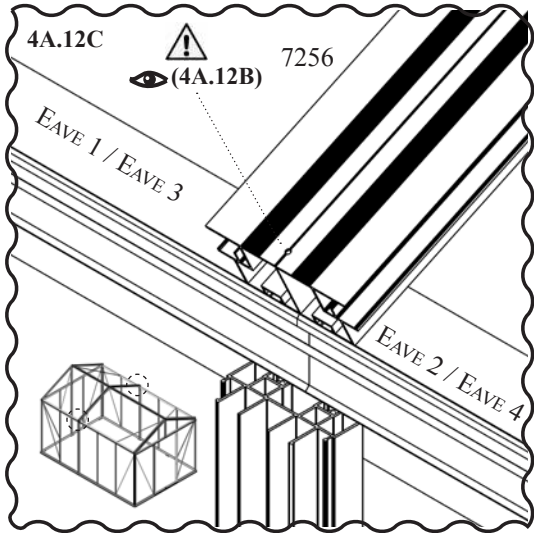

Important!
 Important Tip
 Adjust by Hand
 Mirror of
 Go to



 Important!  Go to

4B

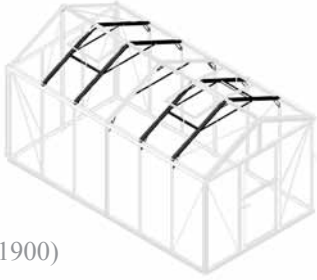

(11900)

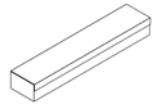
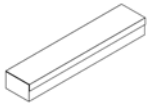

**ROOF, DACH, TOIT, DAK, TAG, TAK, КАЛТО, ТЕТТО, СТРЕСНА,
DACH, STREHA, TETÓ, KROV, КРОВ, АСОРЕРИŞ, STRECHA, КРЫША, ДАХ.**

6200	8100	10000	11900	13800	15700	C4B
1006						Pack 1/1 - 1/6 ZE2 & Pack 2 & Pack 3 - 1/2 & Pack 4 - 1/2 & Pack 5
8x	8x	8x	12x	12x	12x	
6056						
4x	4x	4x	6x	6x	6x	
7047						
-	2x	4x	4x	6x	8x	
7048						
-	-	1x	2x	2x	2x	
7052						
12x	24x	36x	48x	60x	72x	
7053						
12x	24x	36x	48x	60x	72x	
7054						
4x	4x	4x	6x	6x	6x	
7055						
4x	4x	4x	6x	6x	6x	
7062						
1x	2x	3x	4x	5x	6x	
7063						
6x	8x	10x	12x	14x	16x	
7249						Pack 1/1 - 5/6
1x	1x	1x	1x	1x	1x	

6200	8100	10000	11900	13800	15700	C4B
7249						Pack 1/2
-	2x	2x	2x	4x	6x	
7255						
-	4x	4x	4x	8x	12x	
7249						Pack 1F
1x	-	-	-	-	-	
7255						
2x	-	-	-	-	-	
7294						Pack 2
1x	-	-	-	-	-	
7294						
1x	2x	1x	-	-	-	
7249						Pack 3 - 1/2
-	-	1x	2x	1x	-	
7255						
-	-	2x	4x	2x	-	
7294						Pack 4 - 1/2
-	-	1x	2x	1x	-	
7294						
-	-	-	-	1x	2x	
7294						Pack 5
-	-	-	1x	1x	1x	

4B

4B.1
{S4}

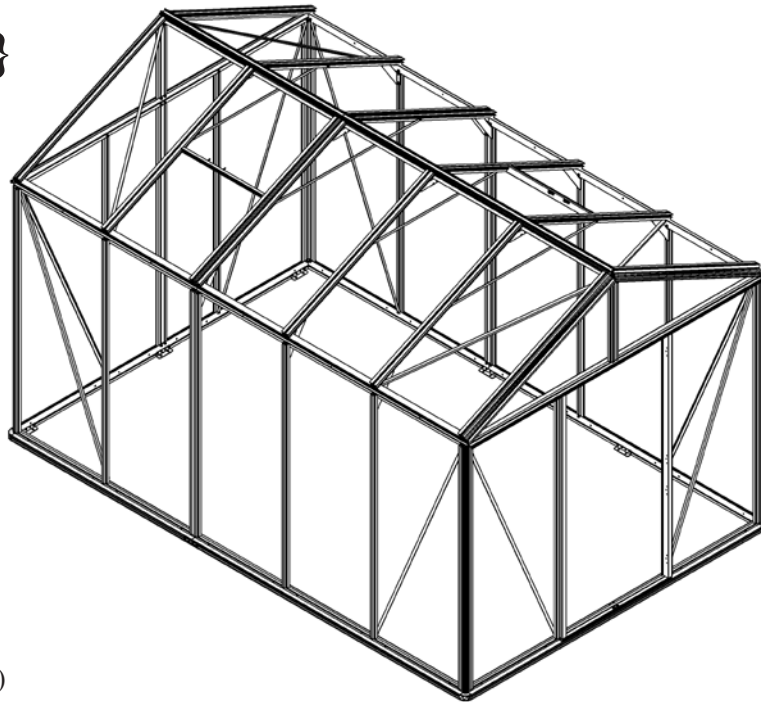

(10000)

4B.2

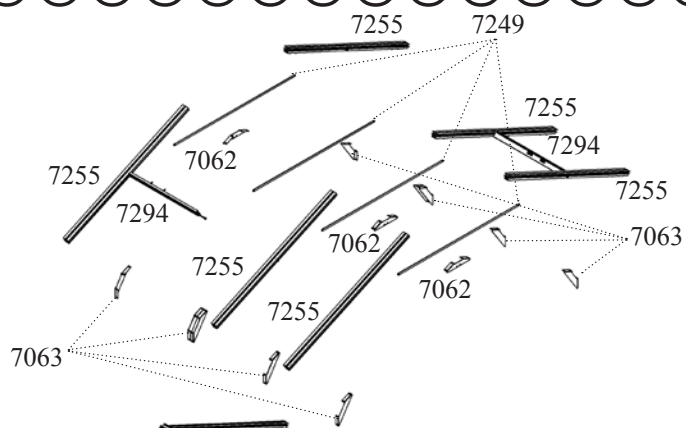

{S4A}

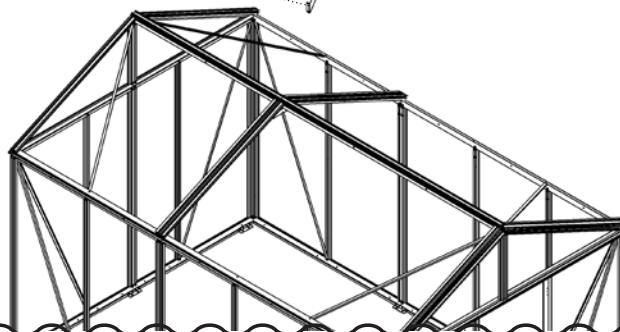

(10000)

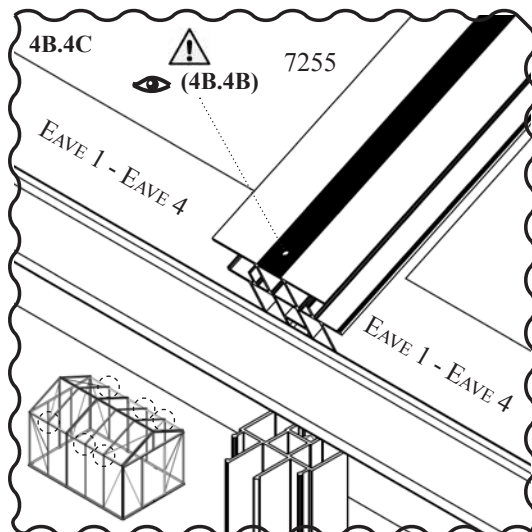
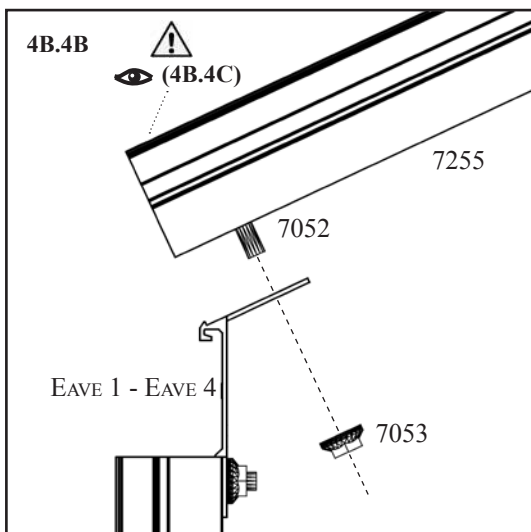
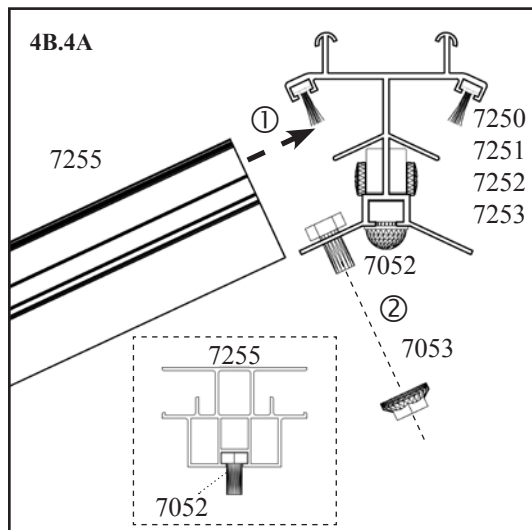
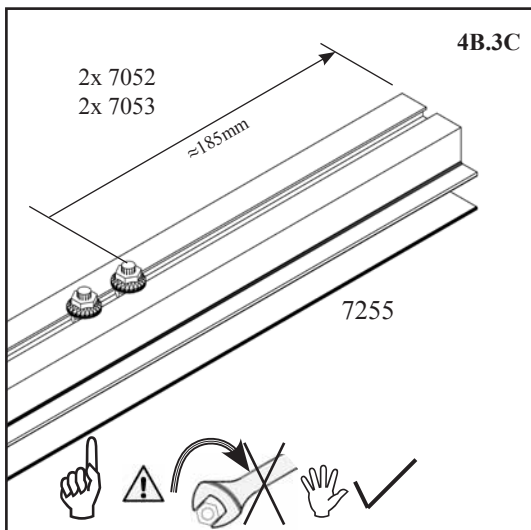
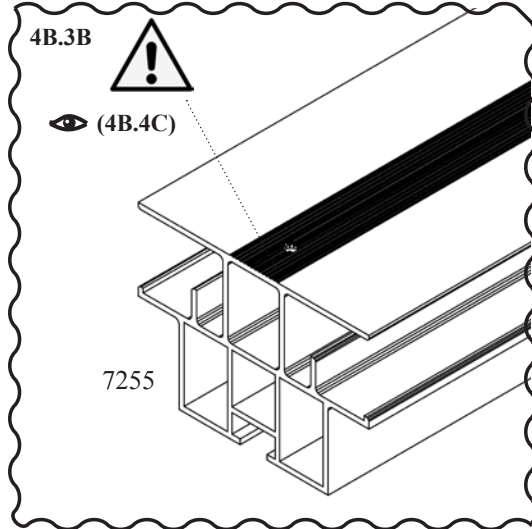
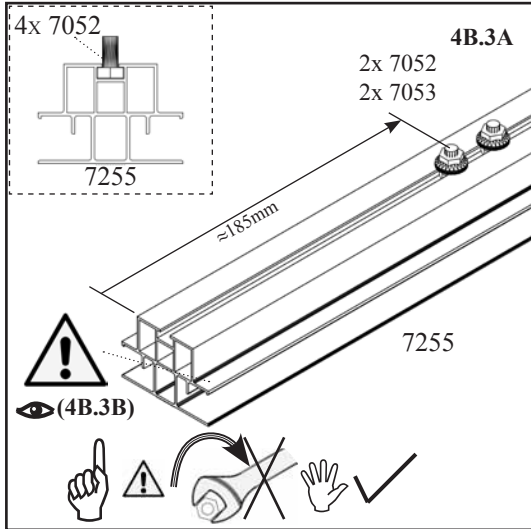
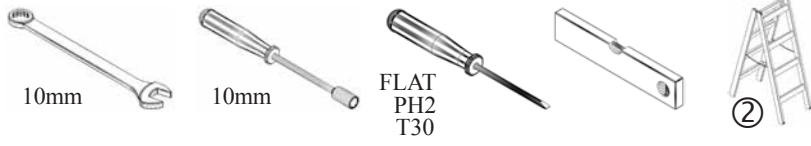

4B

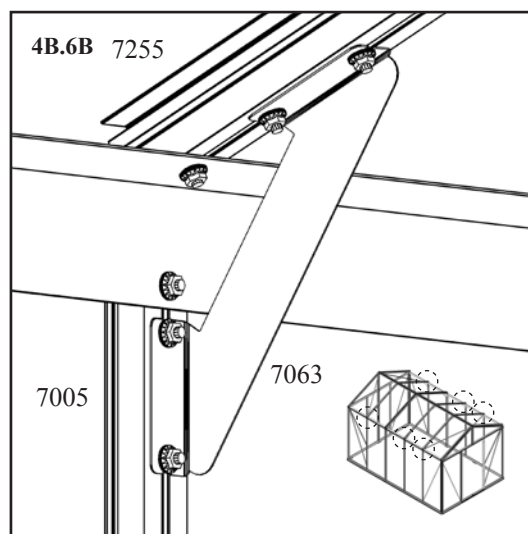
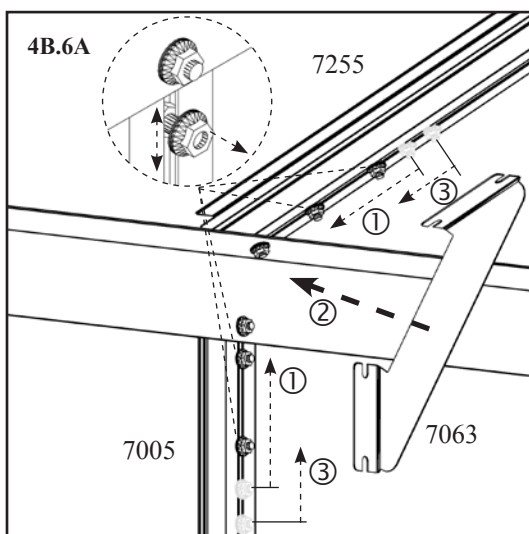
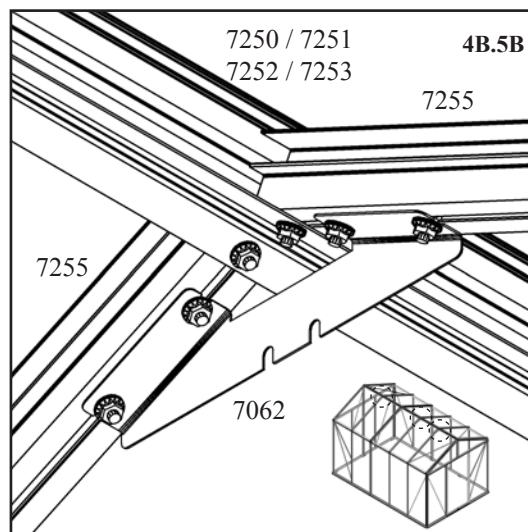
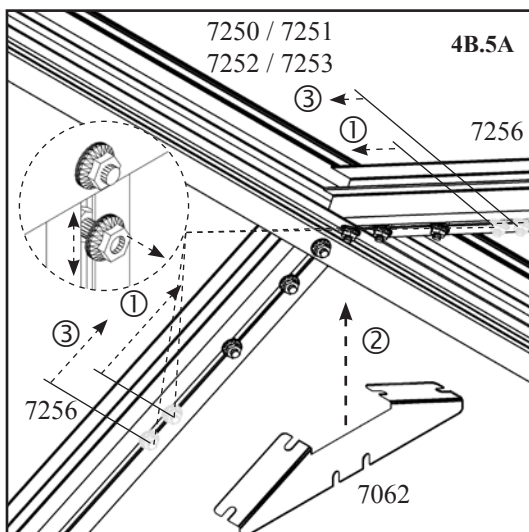
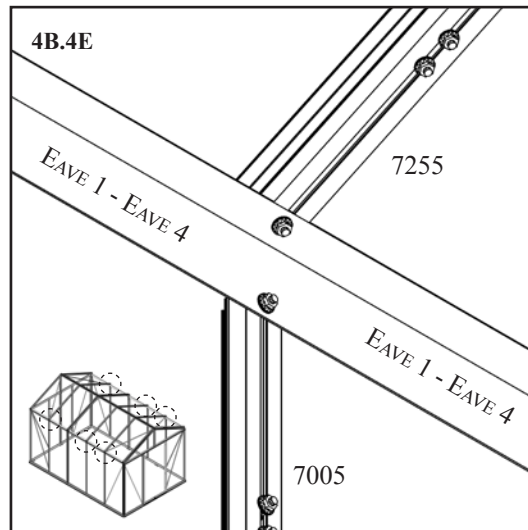
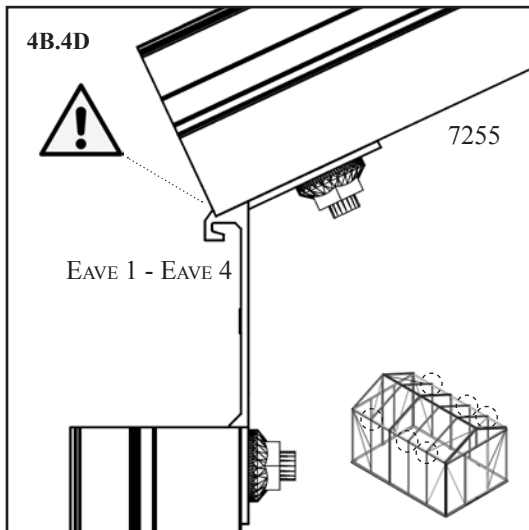

⚠️ Important! 👁️ Go to 🙌 Important Tip 🖐️ Adjust by Hand

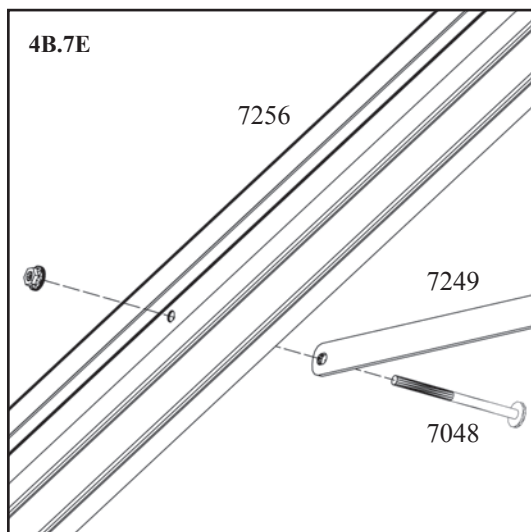
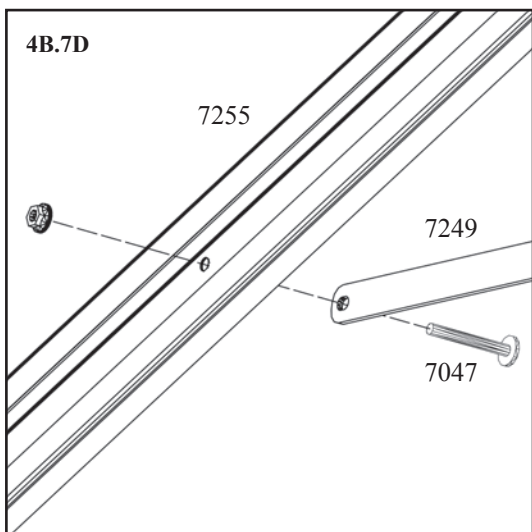
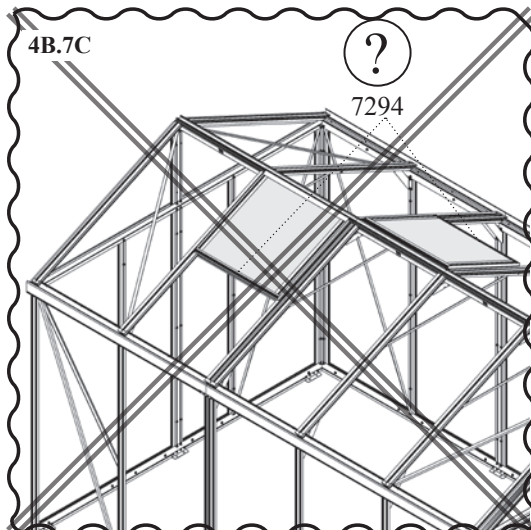
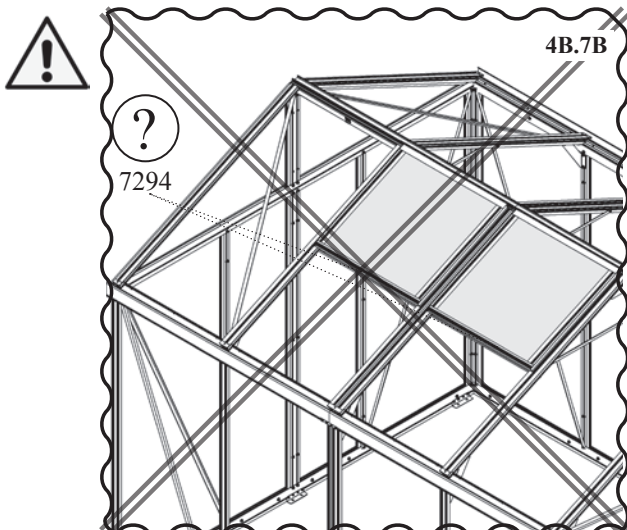
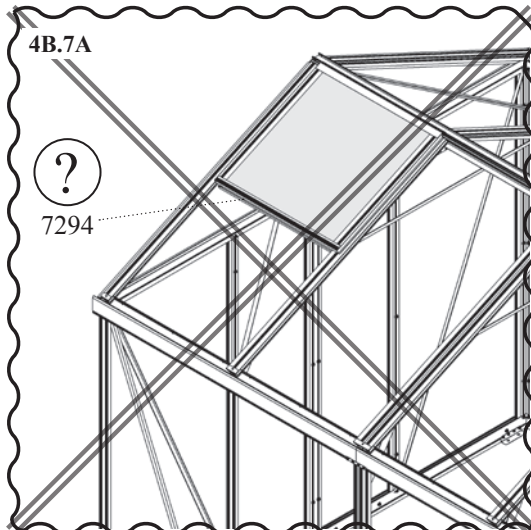
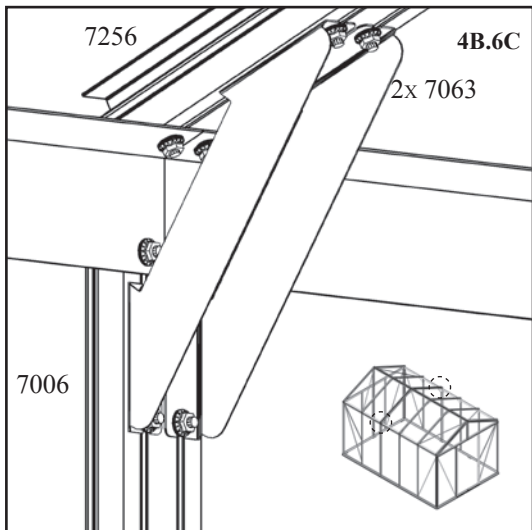



 Important!
  Incorrect!
  Alternative options

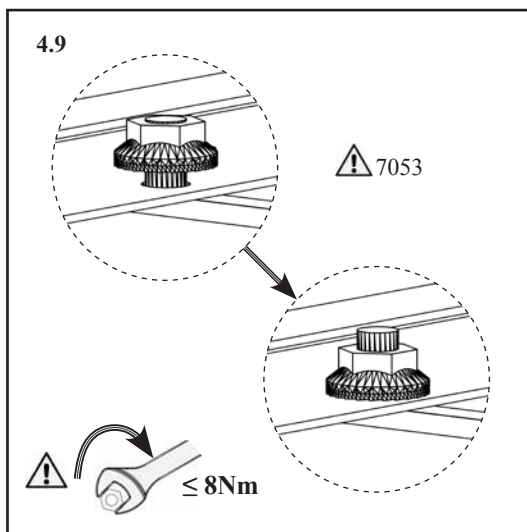
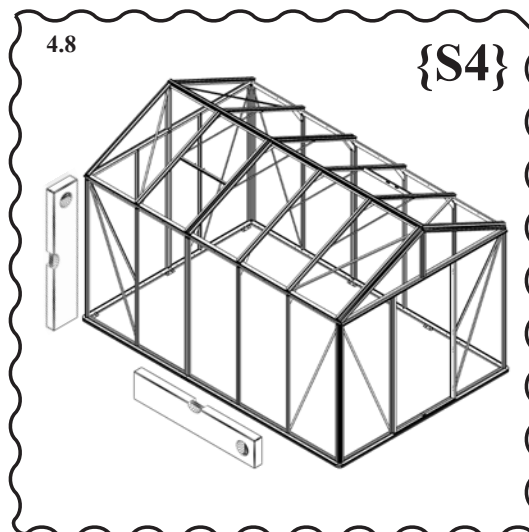
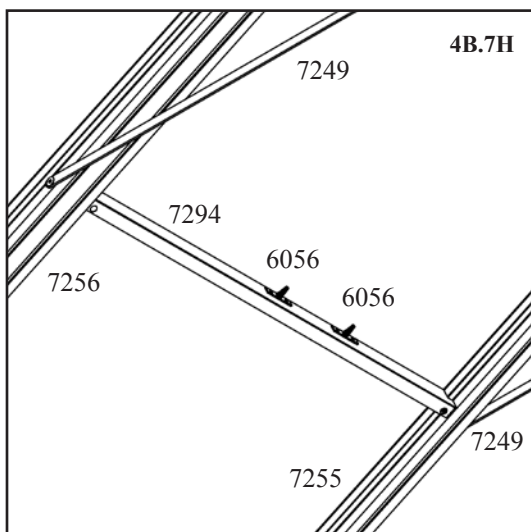
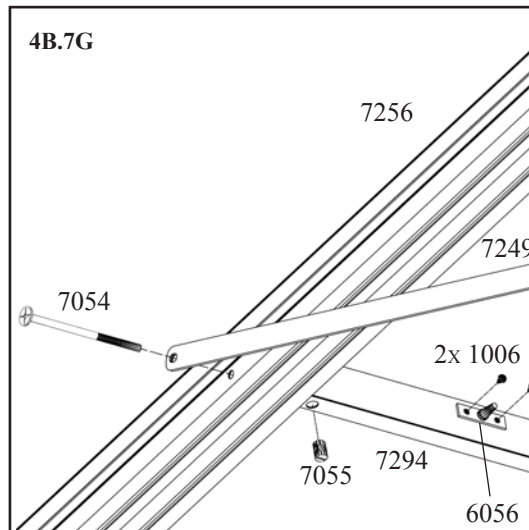
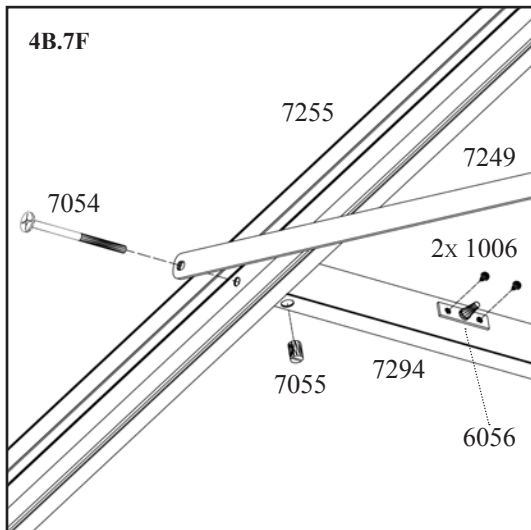

! Important!

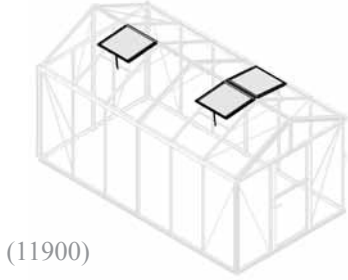

(11900)

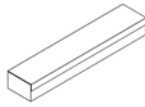

WINDOWS, FENSTER, FENÊTRE, VENSTER, VINDUER, FÖNSTER, VINDUER, IKKUNAT, FINESTRA,
OKNO, OKNA, OKNA, OKNO, ABLAKOK, PROZOR, PROZOR, FERESTRE, OKNÁ, OKHA, BIKHA.

6200	8100	10000	11900	13800	15700	G5
1006						Pack 1F & Pack 2 & Pack 3 - 1/2 & Pack 4 - 1/2 & Pack 5
2x2	2x2	2x2	2x3	2x3	2x3	
7052						
4x2	4x2	4x2	4x3	4x3	4x3	
7053						
4x2	4x2	4x2	4x3	4x3	4x3	
7090						
1x2	1x2	1x2	1x3	1x3	1x3	
7244						
1x2	1x2	1x2	1x3	1x3	1x3	
7247 (7291)						
1x2	1x2	1x2	1x3	1x3	1x3	
7248 (7291)						
1x2	1x2	1x2	1x3	1x3	1x3	
7293						
1x2	1x2	1x2	1x3	1x3	1x3	

5.1
{S5}

{S5}					
6200	8100	10000	11900	13800	15700
2x	2x	2x	3x	3x	3x

D		1x
---	--	----

5.2

- ⒺⓃ Please refer to the glazing instructions which are included together with the glazing panes.
- ⒹⒺ Bitte beachten Sie die Verglasungsanleitung, die den Verglasungsscheiben beiliegt.
- ⒻⓇ Veuillez vous référer aux instructions relatives au vitrage qui sont fournies avec les vitres.
- ⓃⓁ Raadpleeg de beglazingsinstructies die samen met de ruiten worden geleverd.
- Ⓓⓐ Se venligst glasvejledning, som følger med ruderne.
- ⒺⓈ Se glasningsanvisningarna som medföljer glasrutorna.
- Ⓝⓞ Se instruksjonene for innglassing som følger med glassene.
- ⒻⓁ Tutustu lasitusohjeisiin, jotka toimitetaan lasien mukana.
- ⒻⓉ Consultare le istruzioni per l'installazione dei vetri fornite insieme alle lastre di vetro.
- ⒸⓈ Řiďte se pokyny pro zasklívání, které jsou součástí dodávky zasklívacích skel.
- ⒻⓁ Należy zapoznać się z instrukcją szklenia, która jest dołączona do szyb.
- ⒺⓁ Upoštevajte navodila za zasteklitev, ki so priložena zasteklitvenim ploščam.
- ⒻⓇ Kérjük, olvassa el az üvegezési útmutatót, amelyet az üvegezéshez mellékeltek.
- ⒻⓇ Molimo pogledajte upute za ostakljenje koje su priložene zajedno sa staklenim pločama.
- ⒻⓈ Molimo pogledajte upute za zastakljivanje koje su priložene uz stakla.
- ⒻⓇ Vă rugăm să consultați instrucțiunile de aplicare a geamurilor, care sunt incluse împreună cu geamurile.
- ⒺⓀ Prečítajte si návod na zasklievanie, ktorý je súčasťou dodávky zasklievacích skiel.
- ⒻⓇ Пожалуйста, ознакомьтесь с инструкцией по остеклению, которая прилагается к стеклопакетам.
- ⒻⓀ Будь ласка, зверніться до інструкції зі скління, які додаються до склопакетів.

6A

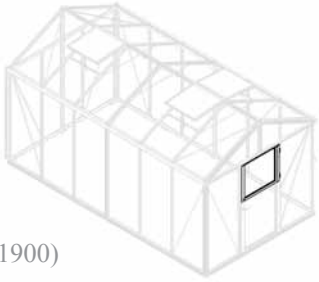

(11900)

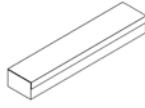

6A.1
{S6A}

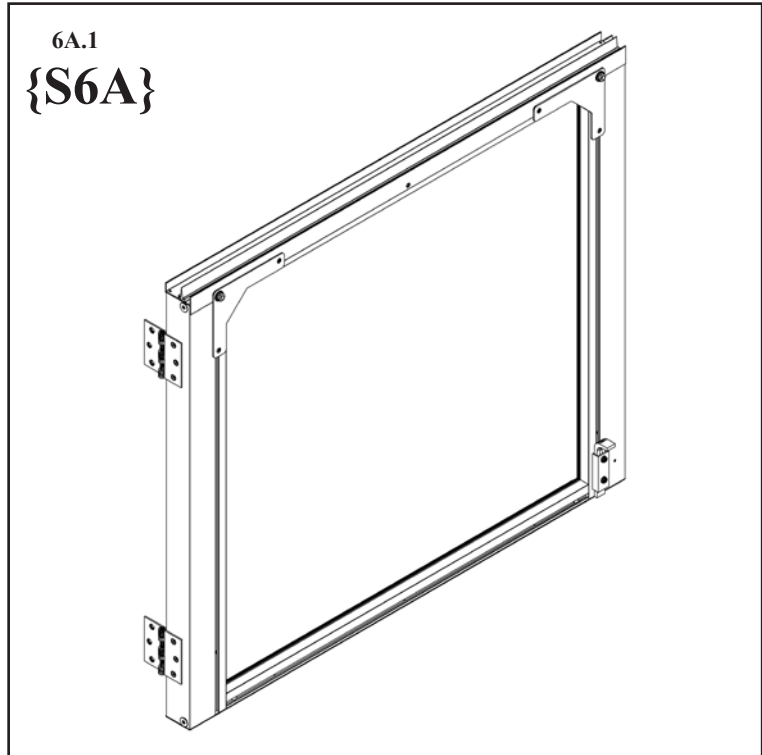

UPPER DOOR, ÖBERE TÜR, PORTE SUPÉRIEURE, BOVENSTE DEUR, ØVERSTE DØRDEL, ÖVRE DÖRRDELEN,
 ØVRE DØR, YLÄÖVI, PORTA SUPERIORE, HORNÍ DVEŘE, GÓRNE DRZWI, ZGORNJA VRATA, FELSŐ AJTÓ,
 GORNJA VRATA, GORNJA VRATA, UŠA SUPERIOARĂ, HORNÉ DVERE, ВЕРХНЯЯ ДВЕРЬ, ВЕРХНІ ДВЕРІ.

All Models	C6A
1006 10x	Pack 1/1 - 1/6 ZE2
7052 2x	
7053 2x	
7054 4x	
7055 4x	
7066 2x	
7085 1x	
7087 2x	
7088 6x	
7114 2x	
7017 1x	
7018 1x	
7022 2x	
7024 1x	
7025 1x	
7083 1x	

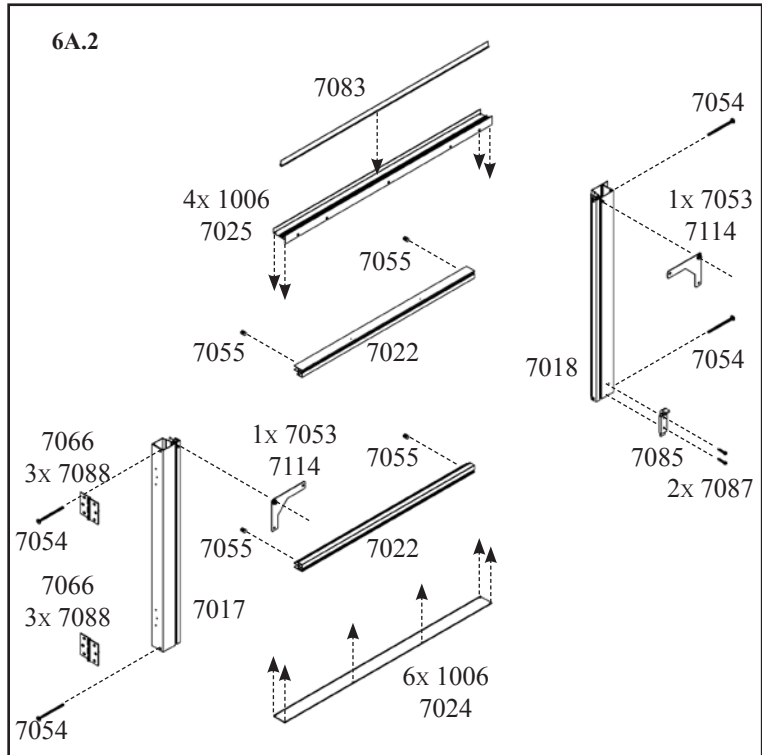

6A

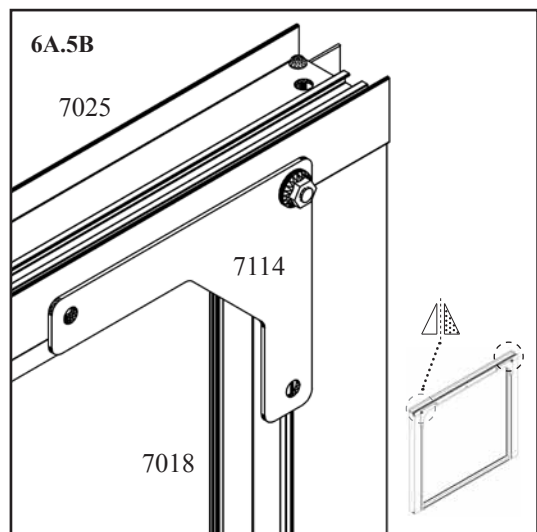
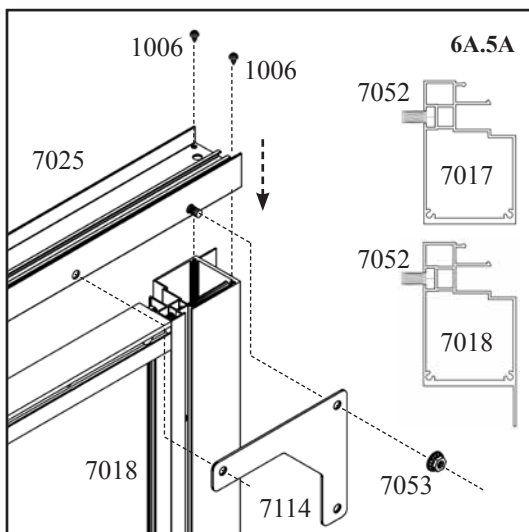
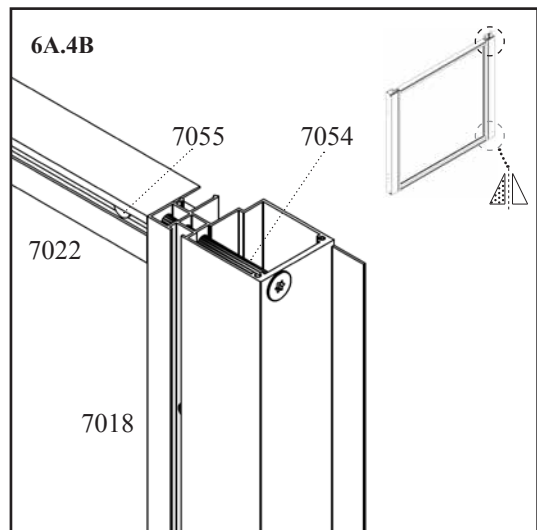
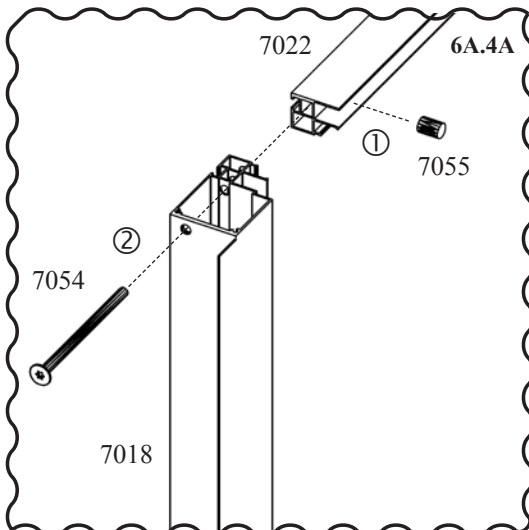
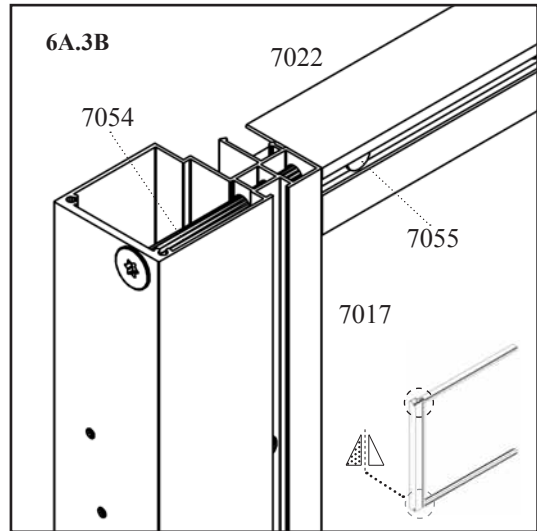
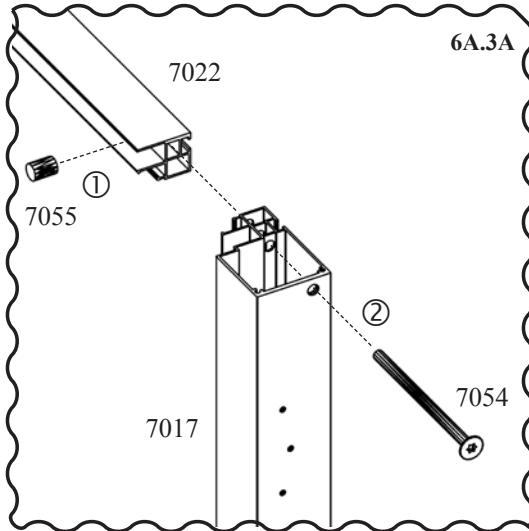

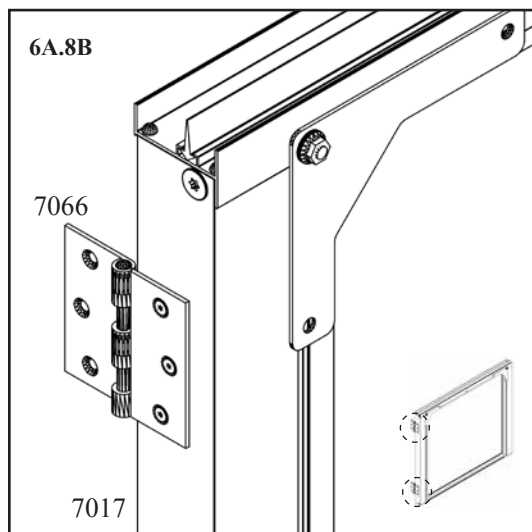
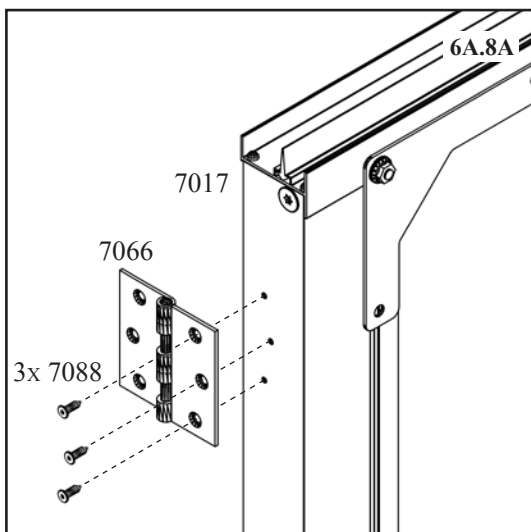
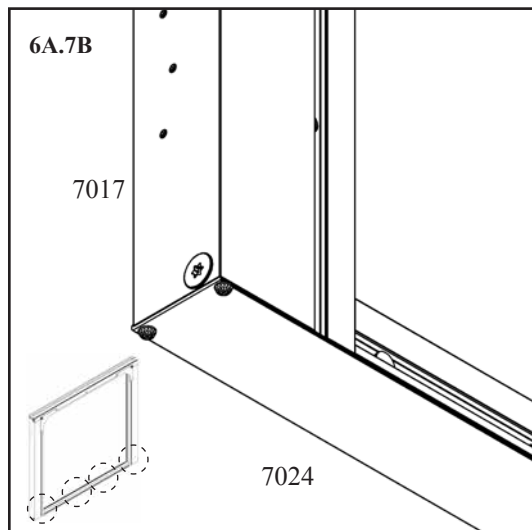
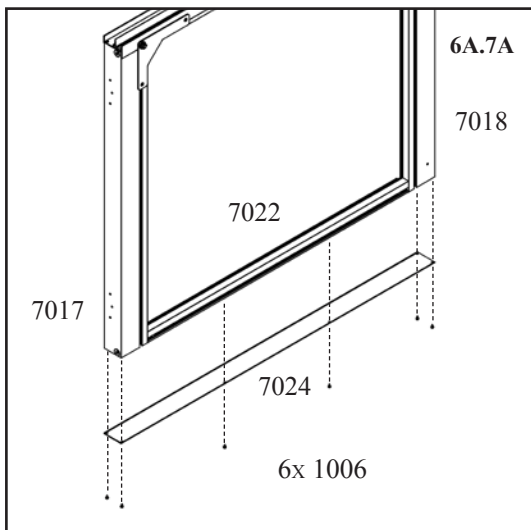
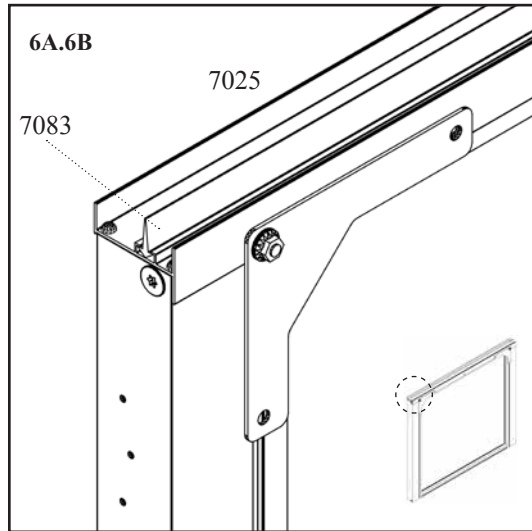
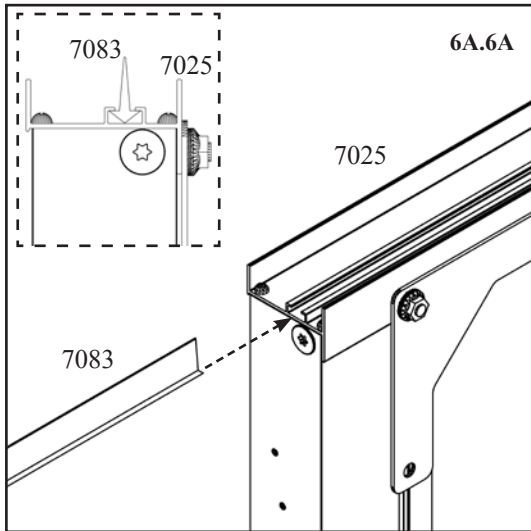

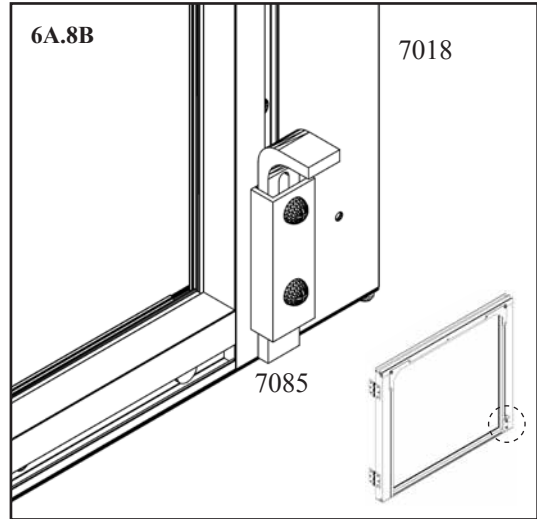
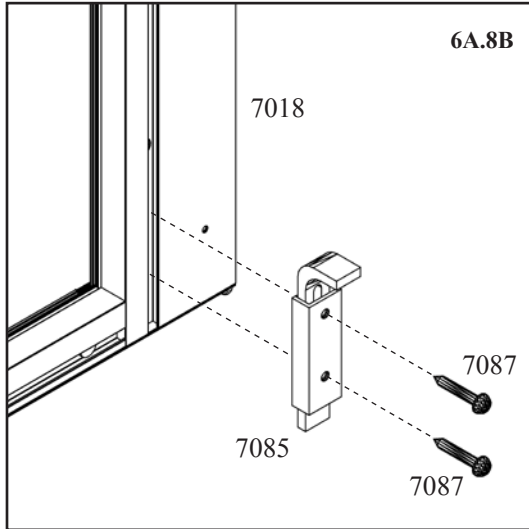

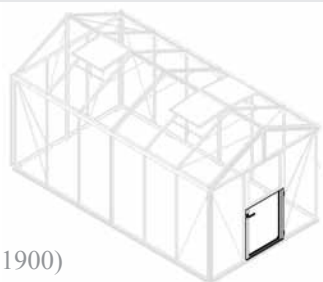

(11900)

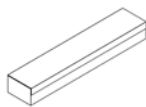

6B.1

{S6B}

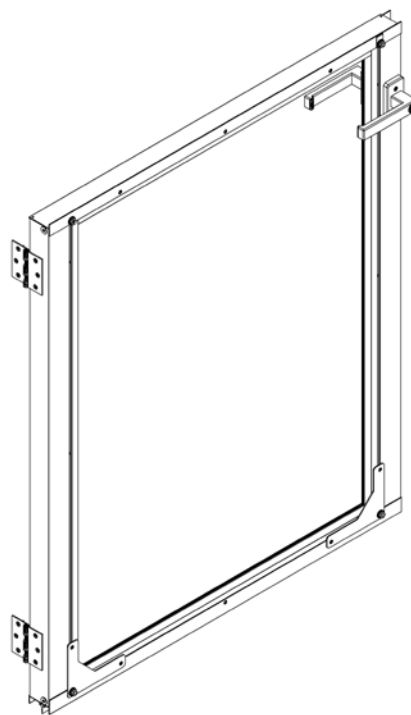

LOWER DOOR, UNTERE TÜR, PORTE INFÉRIEURE, ONDERSTE DØRDEL, NEDERSTE DØRDEL, NEDRE DØRRDELEN,
 NEDRE DØR, ALEMPI OVI, PORTA INFERIORE, DOLNÍ DVEŘE, DOLNE DRZWI, SPODNJA VRATA, ALSÓ AJTÓ,
 DONJA VRATA, DONJA VRATA, UȘA INFERIOARĂ, DOLNÉ DVĚŘE, НИЖНЯ ДВЕРЬ, НИЖНЯ ДВЕРЬ.

All Models	C6B	
1006 8x	Pack 1/1 - 1/6 ZE2	
2010 1x		
2011 1x		
2013 2x		
2019 1x		
2020 1x		
7052 4x		
7053 4x		
7054 4x		
7055 4x		
7066 2x		
7086 1x		
7088 8x		
7114 2x		
7015 1x		Pack 1/1 - 2/6 ZE2
7022 2x		
7023 1x		
7025 1x		
7079 1x		
7083 1x		

6B.2

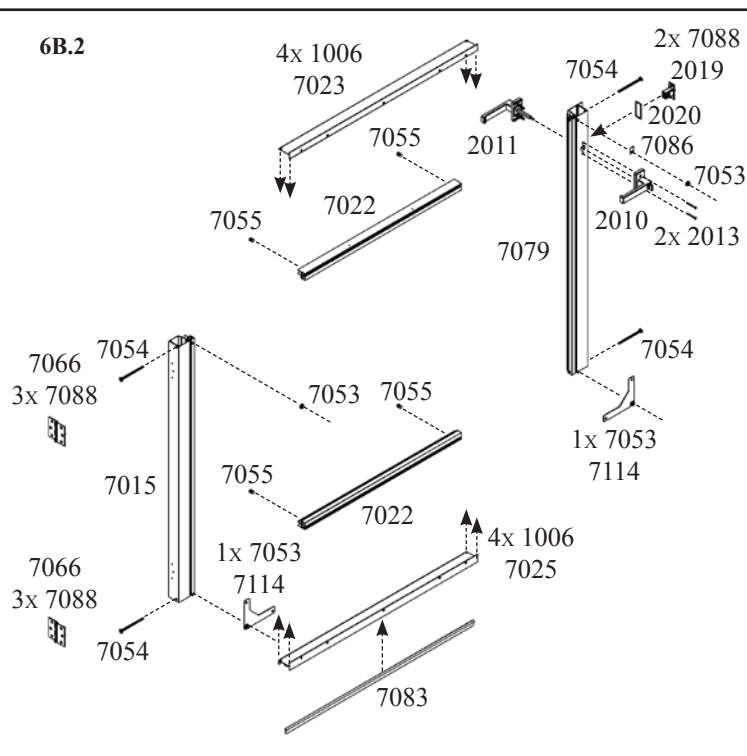

6B

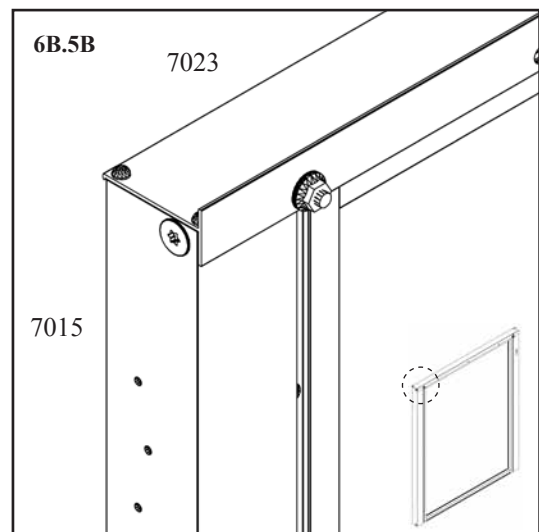
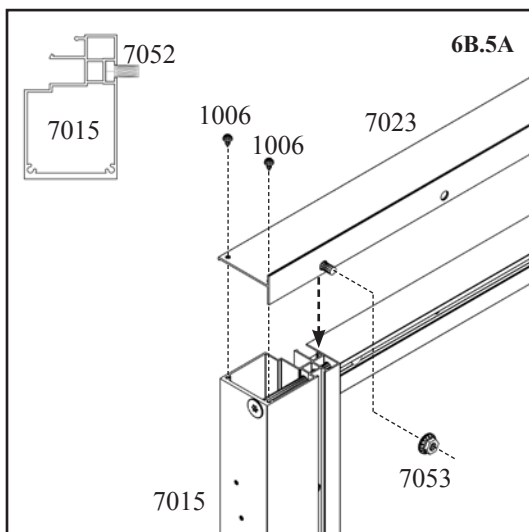
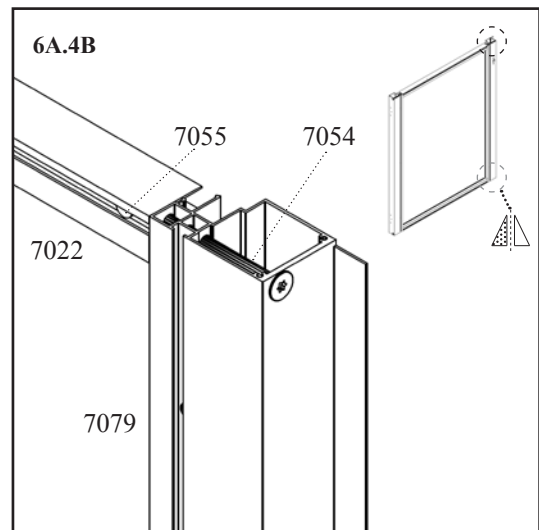
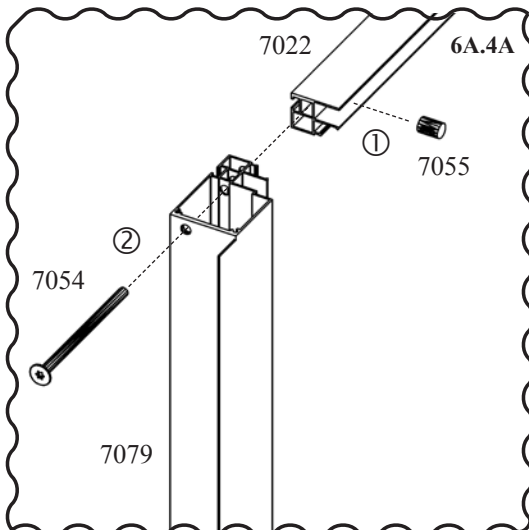
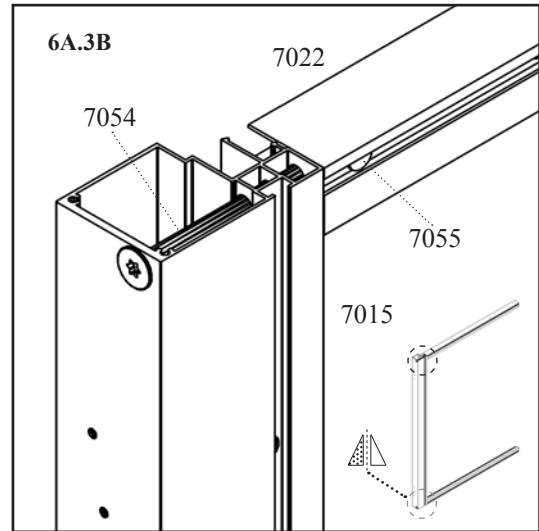
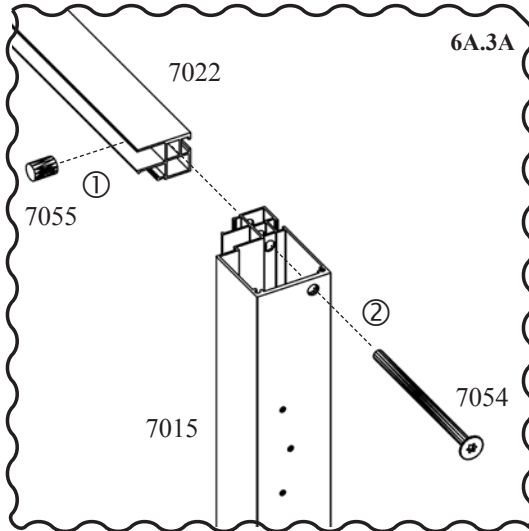

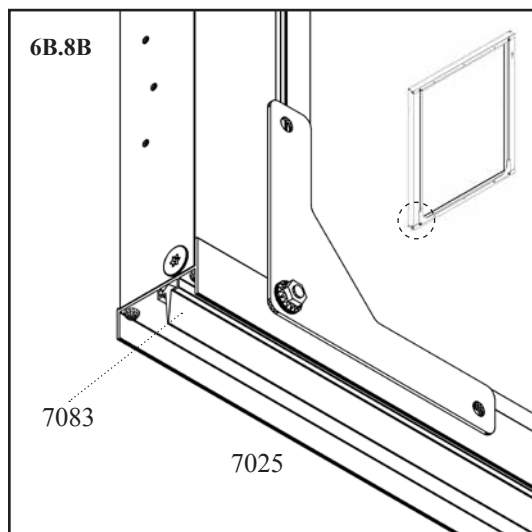
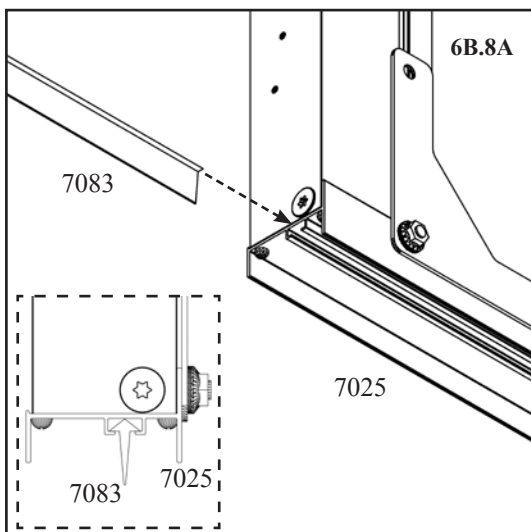
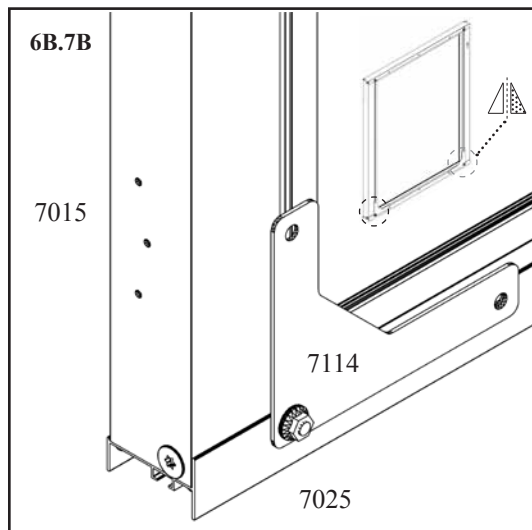
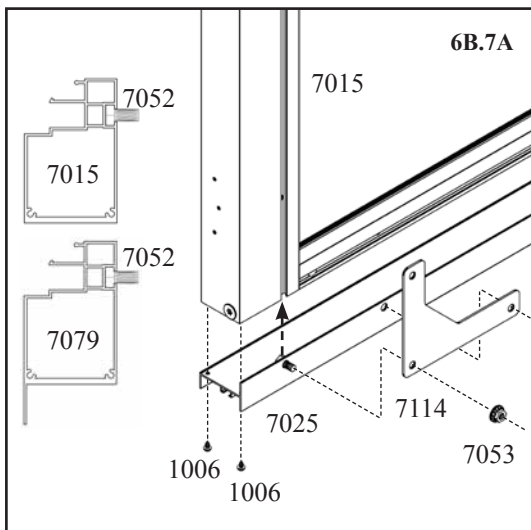
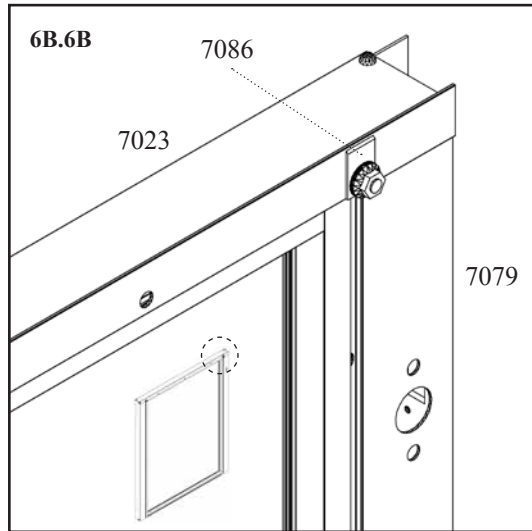
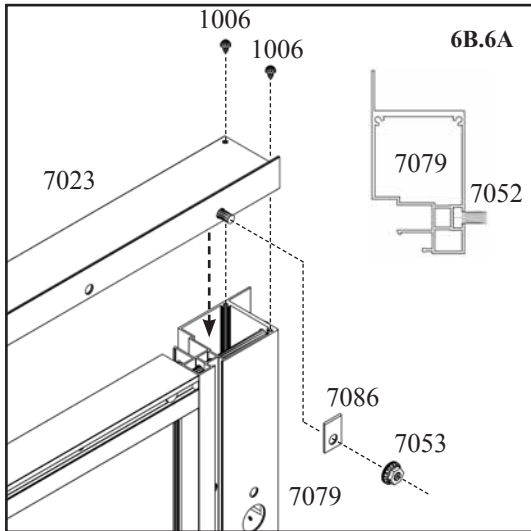

 Mirror of

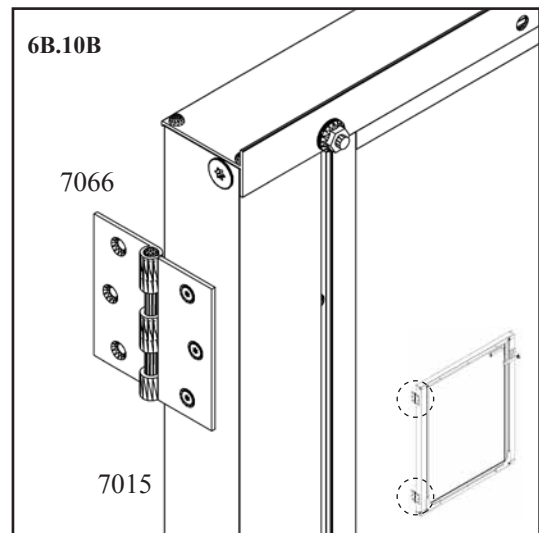
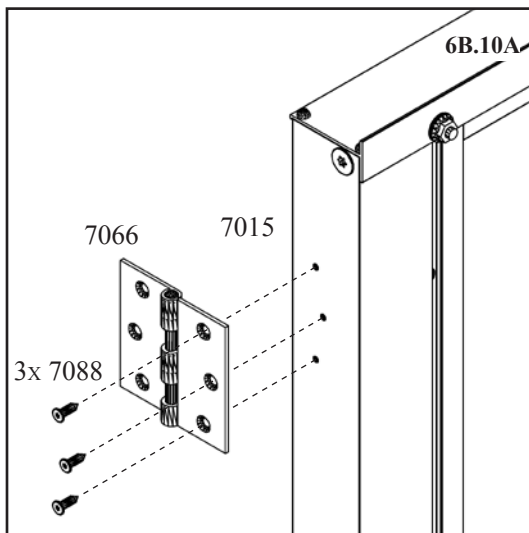
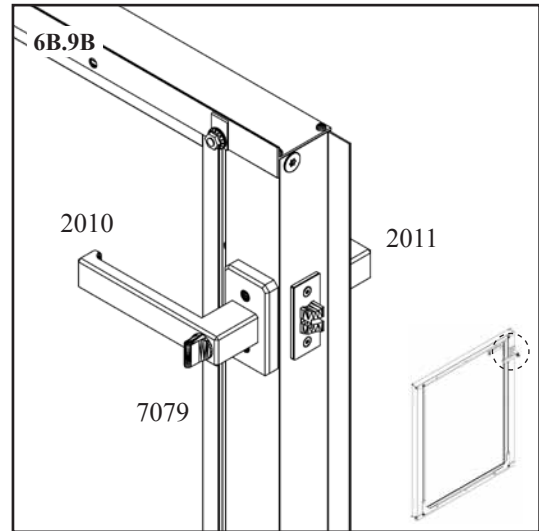
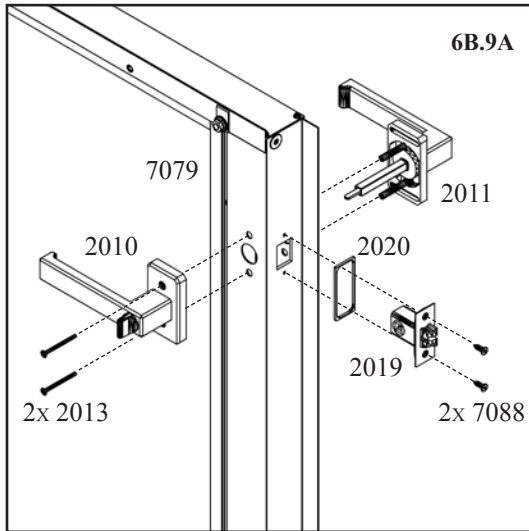

7 {D} {E} {F}

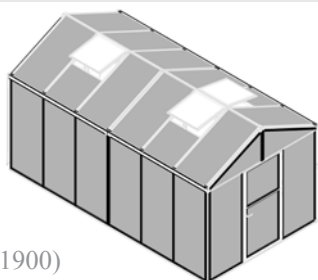

(11900)

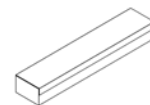
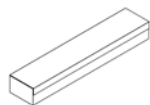
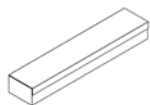

GLAZING, VERGLASUNG, VITRAGE, BEGLAZING, GLAS / POLYCARBONATPLADER, GLAS / POLYKARBONAT, VINDUER, LASITUS, VĚTRATURA, PŘEHLEDNÝ PLÁN ZASKLENÍ, PRZESZKLENIE, ZASTEKLITEV, ÜVEGEZÉS, OSTAKLJENJE, ZASTAKLJIVANJE, GEAMURI, ZASKLENIE, ОСТЕКЛЕНИЕ, СКЛО.

6200	8100	10000	11900	13800	15700	C7
6090						Pack 1/1 - 1/6 ZE2 & Pack 1F & Pack 2 & Pack 3 1/2 & Pack 4 1/2
1x						
7052						
6x	8x	10x	12x	14x	16x	
7053						
132x	144x	156x	168x	180x	192x	
7061						
2x						
7064						
2x						
7080						
8x						
7289						
116x	126x	136x	146x	156x	166x	
7296						
6x	8x	10x	12x	14x	16x	
7297						
6x	8x	10x	12x	14x	16x	
7298*						
10x	14x	18x	21x	25x	29x	
7299*						
10x	14x	18x	21x	25x	29x	
7343						
2x	4x	6x	8x	10x	12x	

6200	8100	10000	11900	13800	15700	C7
7349						Pack 1/1 - 1/6 ZE2 & Pack 1F & Pack 2 & Pack 3 1/2 & Pack 4 1/2
34x	46x	58x	68x	80x	92x	
7406						
12x	14x	16x	18x	20x	22x	
7407						
12x	14x	16x	18x	20x	22x	

6200	8100	10000	11900	13800	15700	C7
7240						Pack 1/1 - 1/6 ZE2
2x						
7288						
10x						
7292						
2x						
7342						
4x						
7408						
8x						
7409						
8x						
7497						
1x						
7031						Pack 1/1 - 2/6 ZE2
2x						
7035						
2x						
7034						Pack 1/1 - 3/6 ZE2
6x						

7 {D} {E} {F}

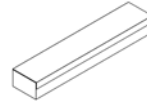
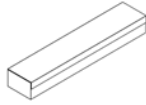

6200	8100	10000	11900	13800	15700	C7
7030						Pack 1/1 - 6/6
2x						
7032						
2x						
7033						
14x						
7034						
2x						
7044						
2x						
7074						
2x						
7075						
2x						
7276						
2x						
7277						
2x						
7032						Pack 1/2
-	4x	4x	4x	8x	12x	

6200	8100	10000	11900	13800	15700	C7
7032						Pack 1F
2x	-	-	-	-	-	
7034						
2x	-	-	-	-	-	
7223						Pack 2
2x	-	-	-	-	-	
7034						
4x	8x	4x	-	-	-	
7213						Pack 3 - 1/2
2x	4x	2x	-	-	-	
7034						Pack 3 - 2/2
-	-	6x	12x	6x	-	
7032						Pack 3 - 1/2
-	-	2x	4x	2x	-	
7214						Pack 4 - 1/2
-	-	2x	4x	2x	-	
7034						Pack 4 - 2/2
-	-	-	-	8x	16x	
7215						Pack 4 - 2/2
-	-	-	-	2x	4x	

{S4} 1x		
{S6A} 1x		-
{S6B} 1x		

7 {D} {E} {F}

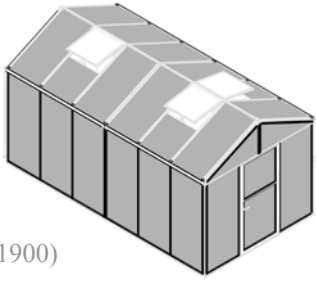

(11900)

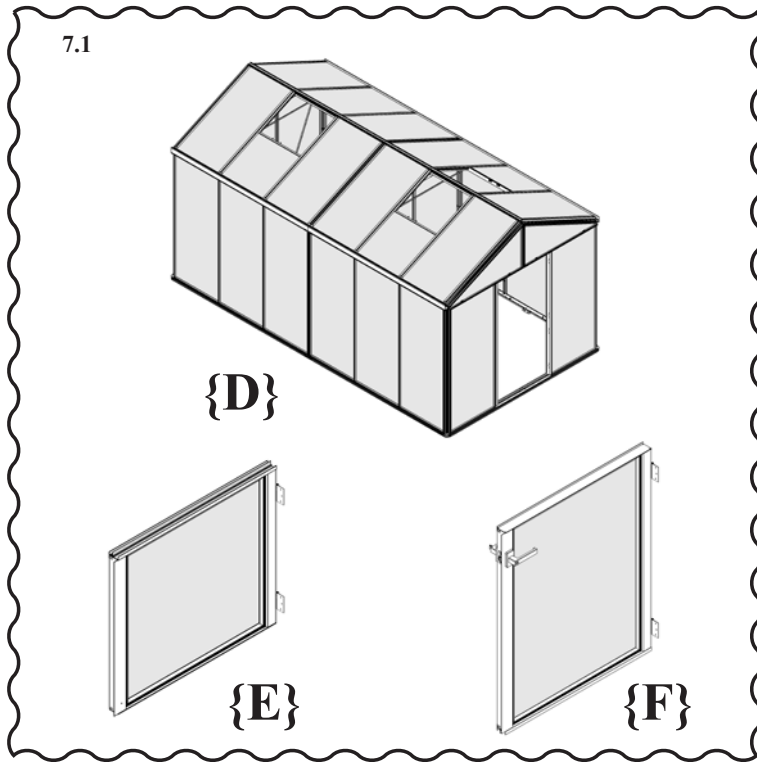

7 {D} {E} {F}



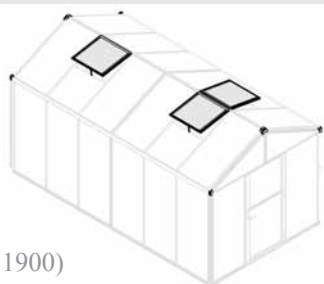



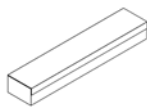

- Ⓔ Please refer to the glazing instructions which are included together with the glazing panes.
- Ⓕ Bitte beachten Sie die Verglasungsanleitung, die den Verglasungsscheiben beiliegt.
- Ⓖ Veuillez vous référer aux instructions relatives au vitrage qui sont fournies avec les vitres.
- Ⓗ Raadpleeg de beglazingsinstructies die samen met de ruiten worden geleverd.
- Ⓙ Se venligst glasvejledningerne, som følger med ruderne.
- Ⓚ Se glasningsanvisningarna som medföljer glasrutorna.
- Ⓝ Se instruksjonene for innglassing som følger med glassene.
- Ⓕ Tutustu lasitusohjeisiin, jotka toimitetaan lasien mukana.
- Ⓙ Consultare le istruzioni per l'installazione dei vetri fornite insieme alle lastre di vetro.
- Ⓕ Řiďte se pokyny pro zasklívání, které jsou součástí dodávky zasklívacích skel.
- Ⓕ Należy zapoznać się z instrukcją szklenia, która jest dołączona do szyb.
- Ⓕ Upoštevajte navodila za zasteklitev, ki so priložena zasteklitvenim ploščam.
- Ⓕ Kérjük, olvassa el az üvegezési útmutatót, amelyet az üvegezéshez mellékeltek.
- Ⓕ Molimo pogledajte upute za ostakljenje koje su priložene zajedno sa staklenim pločama.
- Ⓕ Molimo pogledajte upute za zastakljivanje koje su priložene uz stakla.
- Ⓕ Vă rugăm să consultați instrucțiunile de aplicare a geamurilor, care sunt incluse împreună cu geamurile.
- Ⓕ Prečítajte si návod na zasklievanie, ktorý je súčasťou dodávky zasklievacích skiel.
- Ⓕ Пожалуйста, ознакомьтесь с инструкцией по остеклению, которая прилагается к стеклопакетам.
- Ⓕ Будь ласка, зверніться до інструкції зі скління, які додаються до склопакетів.





(11900)



FINISHING, ABSCHLUSSARBEITEN, TRAVAUX DE FINITION, AFWERKING,
 FÆRDIGGØRELSE, FÆRDIGSTÅLLNING, ETTERBEHANDLING, VIIMEISTELY, LAVORI FINALI, ZÁVĚREČNÉ PRÁCE,
 WYKOŃCZENIE, ZAKŁUČNA DELA, BEFEJZÉS, ZAVRŠNA OBRADA, ZAVRŠNA OBRADA, FINISARE, DOKONČOVACIE
 PRÁCE, ОТДЕЛКА, ЗАКЛУЧУВАННЯ.

6200	8100	10000	11900	13800	15700	C8A
7088 4x						Pack 1/1 - 1/6 ZE2 & Pack 1F & Pack 2 & Pack 3 - 1/2 & Pack 4 - 1/2 & Pack 5
7128 1x						
7129 1x						
7266 2x						
7349						
4x	4x	4x	6x	6x	6x	
7369						
4x	4x	4x	6x	6x	6x	
7370 1x						
7371 1x						

6200	8100	10000	11900	13800	15700
{D} 1x					
{S5}					
2x	2x	2x	3x	3x	3x

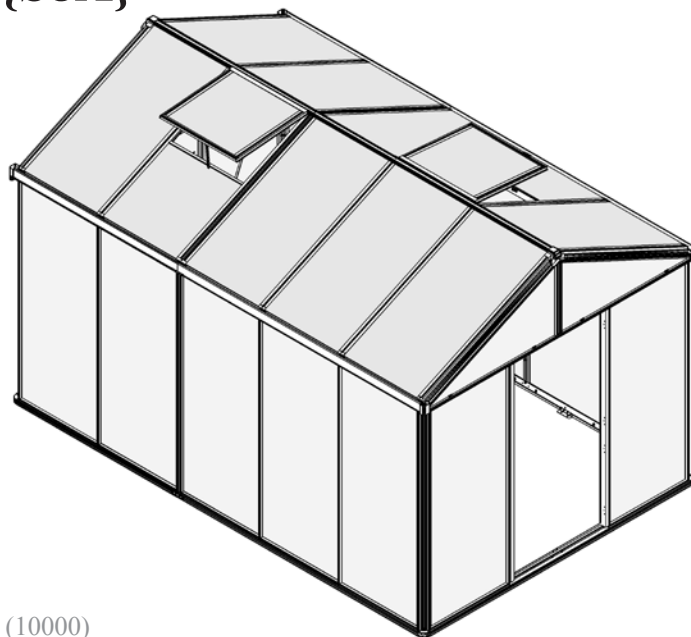
8A.1
{S8A}

(10000)

8A.2

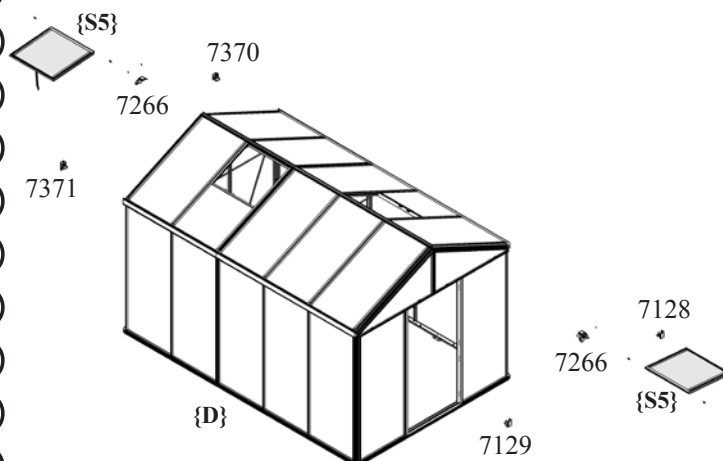

(10000)

8A

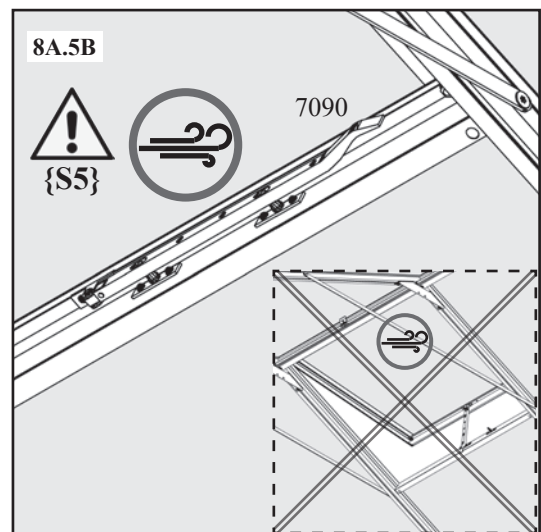
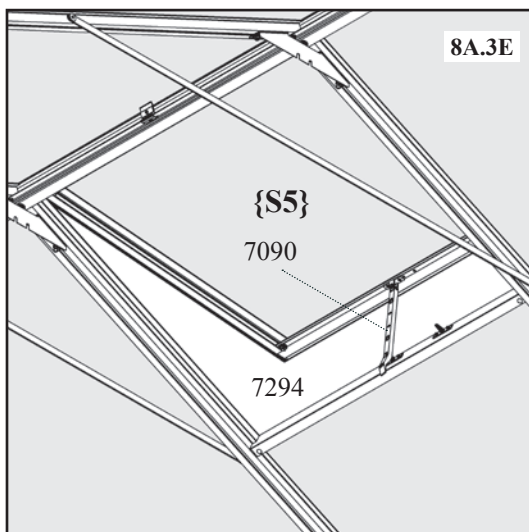
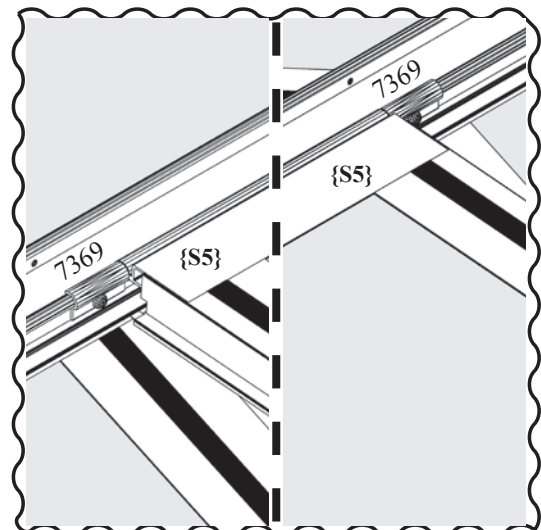
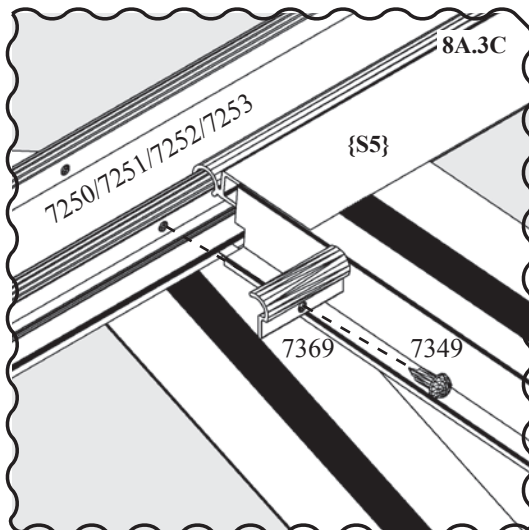
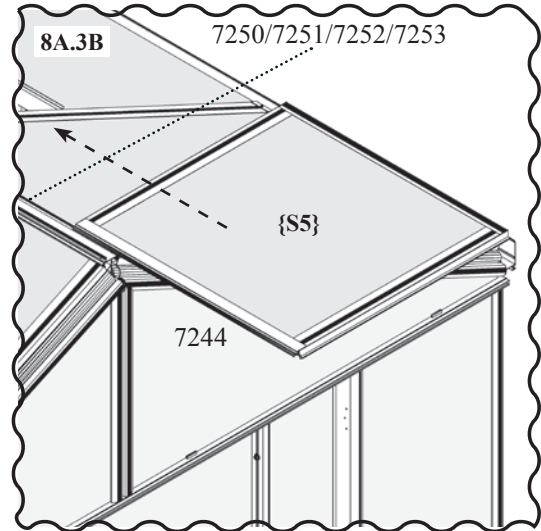
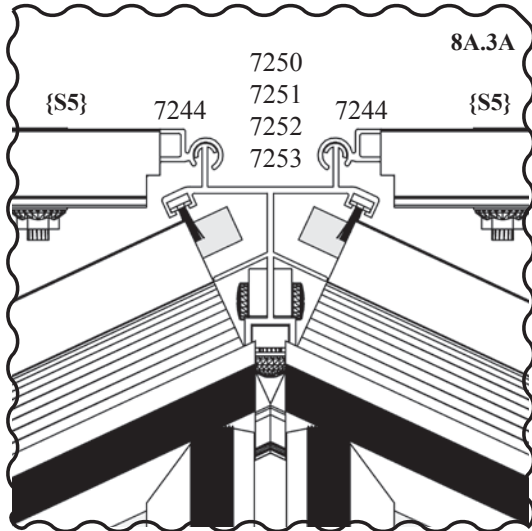

Important!



High Wind



Incorrect!

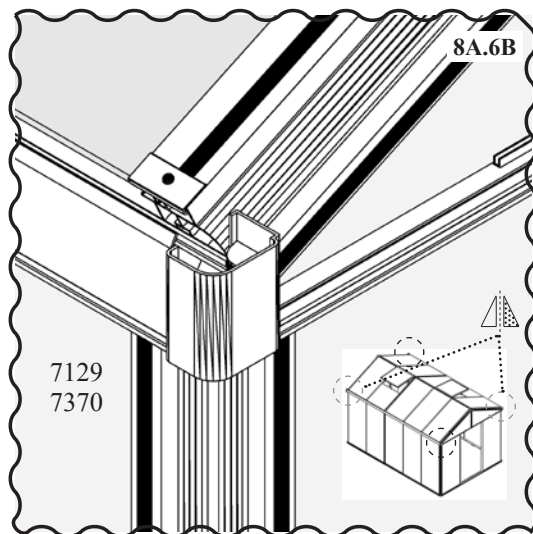
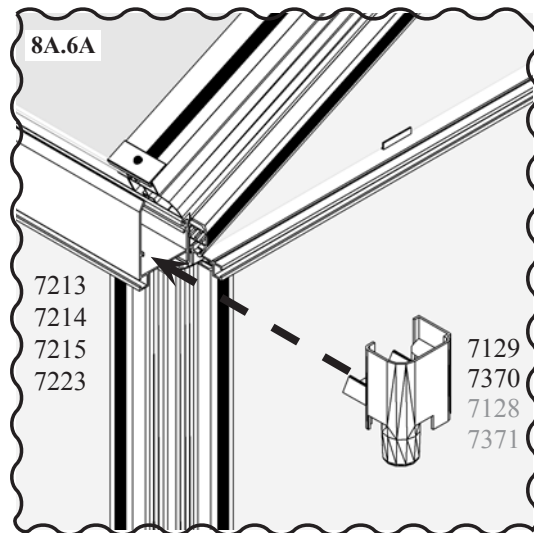
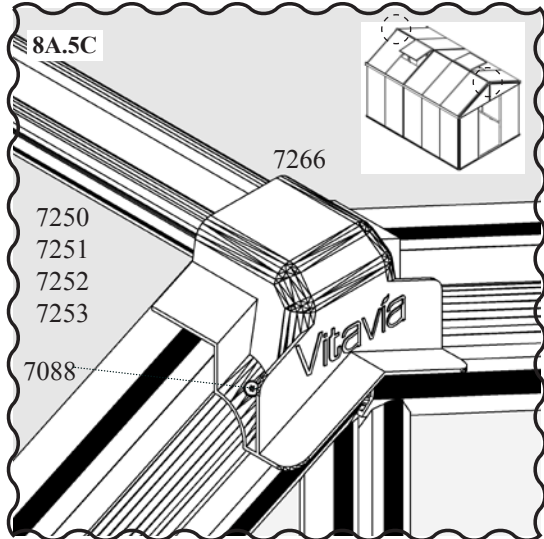
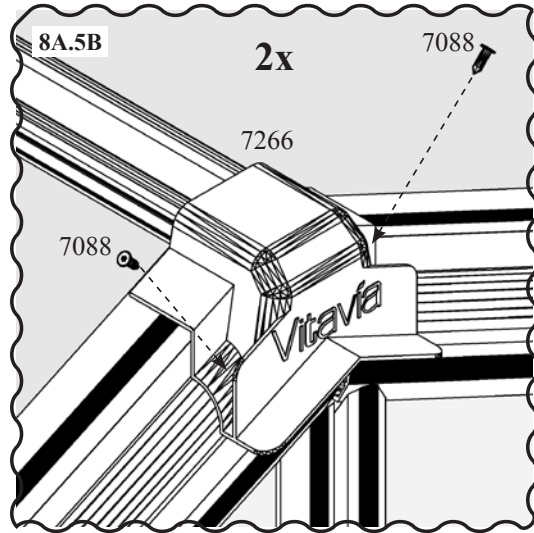
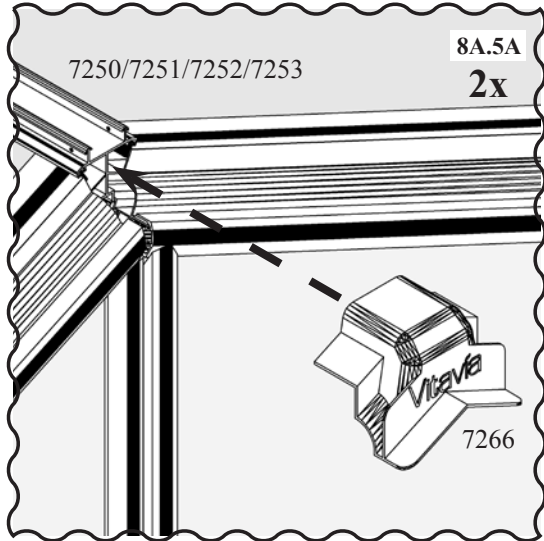

 Mirror of

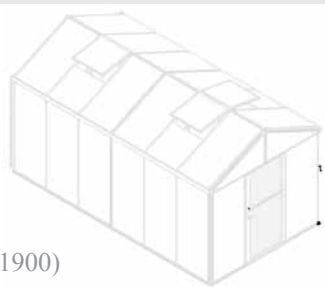

(11900)



FINISHING, ABSCHLUSSARBEITEN, TRAVAUX DE FINITION, AFWERKING,
 FÆRDIGGØRELSE, FÆRDIGSTÅLLNING, ETTERBEHANDLING, VIIMEISTELY, LAVORI FINALI, ZÁVĚREČNÉ PRÁCE,
 WYKOŃCZENIE, ZAKŁUČNA DELA, BEFEJZÉS, ZAVRŠNA OBRADA, ZAVRŠNA OBRADA, FINISARE, DOKONČOVACIE
 PRÁCE, ОТДЕЛКА, ЗАКЛУЧУВІО.

5800	8500	11200	13900	16600	C8B
2026	1x				Pack 1/1 - 1/6 ZE2
7053	3x				
7088	14x				
7111	1x				
7112	1x				
7113	1x				
7283	1x				
7399	3x				

{S8A}	1x		-
{E}	1x		-
{F}	1x		-

8B.1

{S8B}

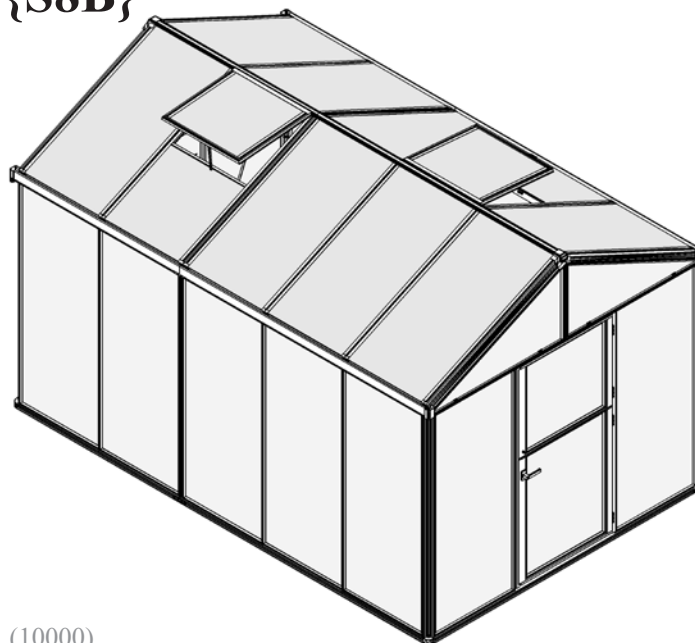

(10000)

8B.2

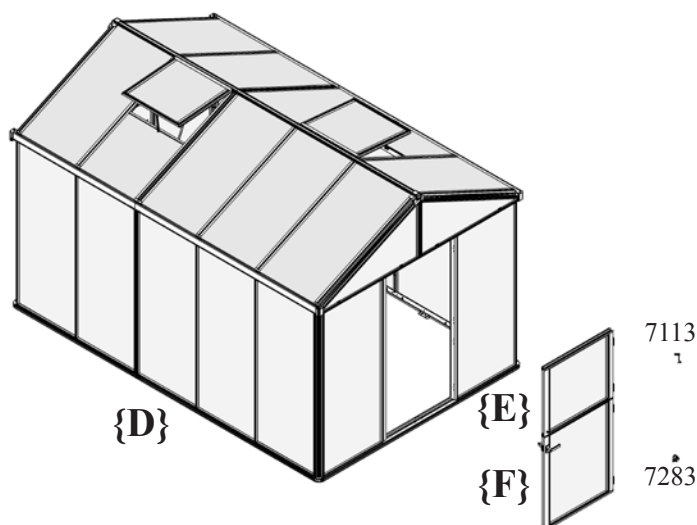

(10000)

8B

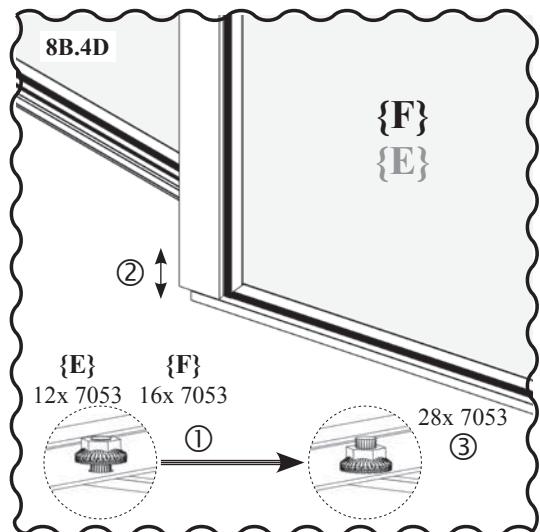
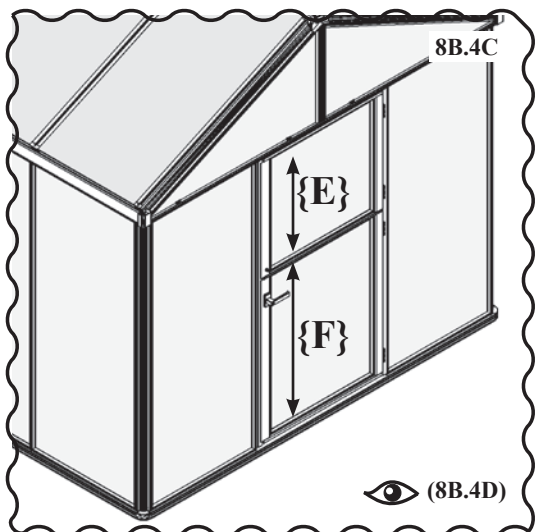
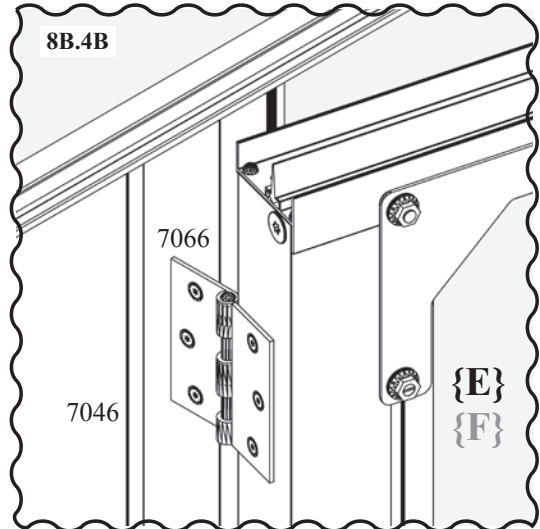
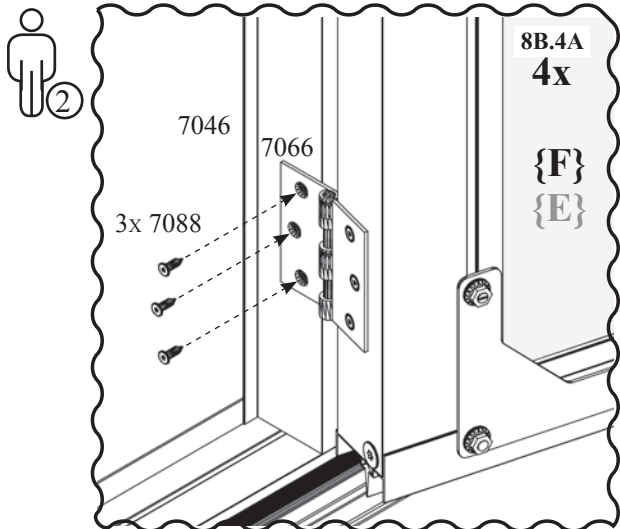
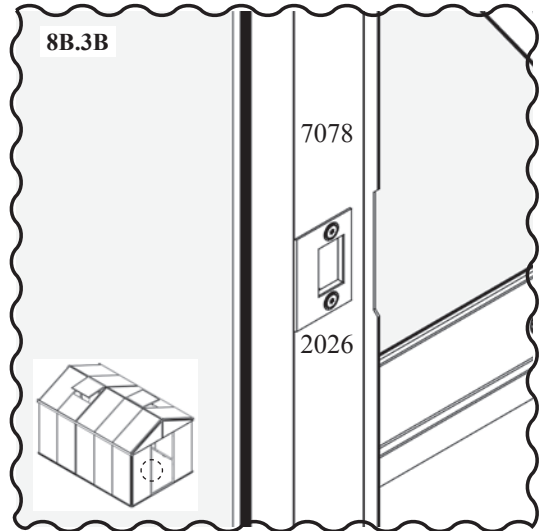
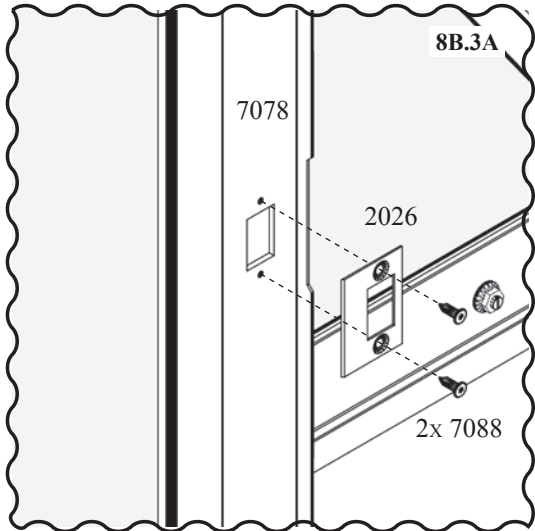

② Persons required. 👁 Look closely

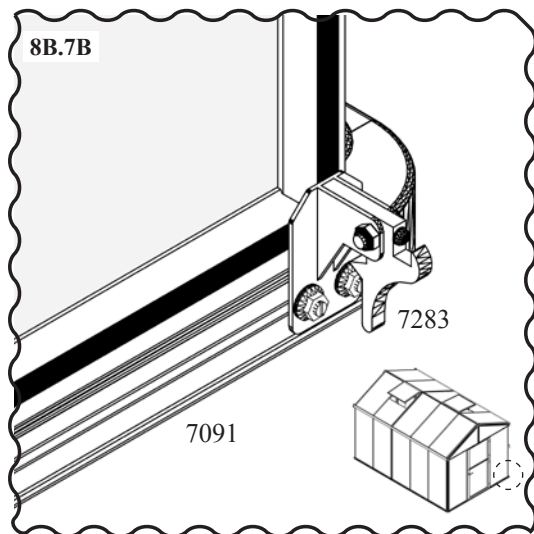
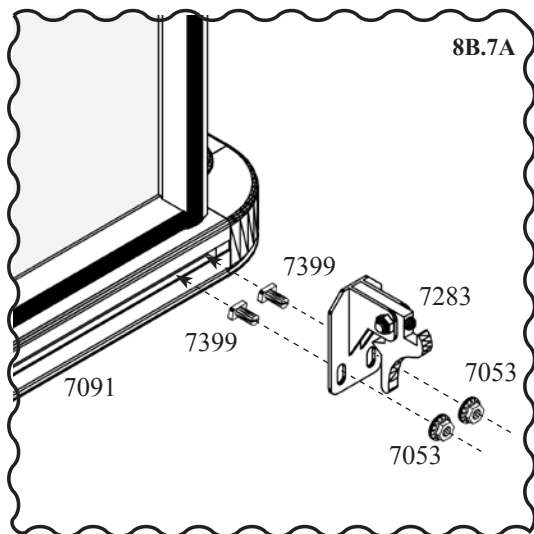
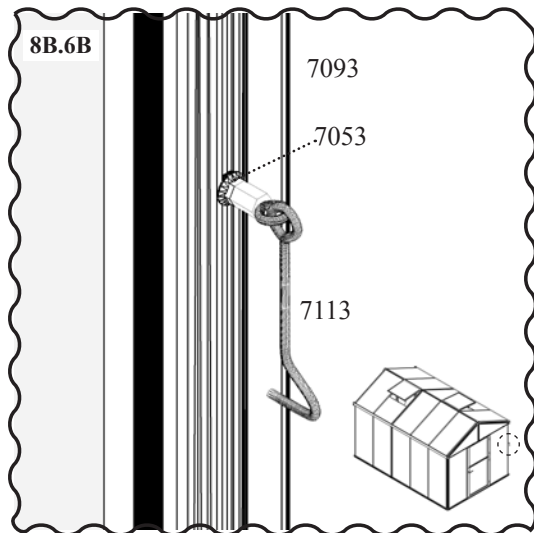
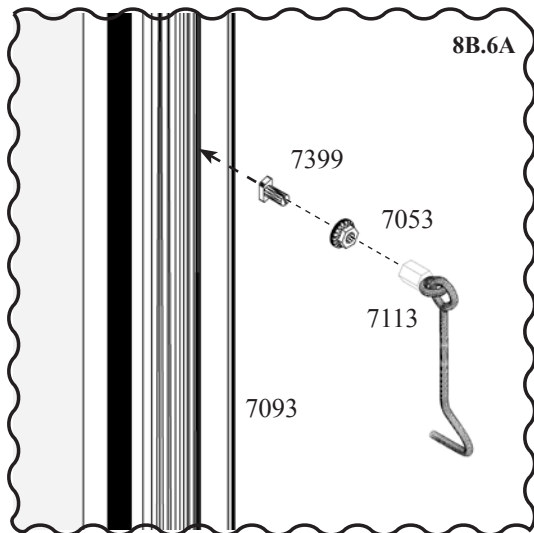
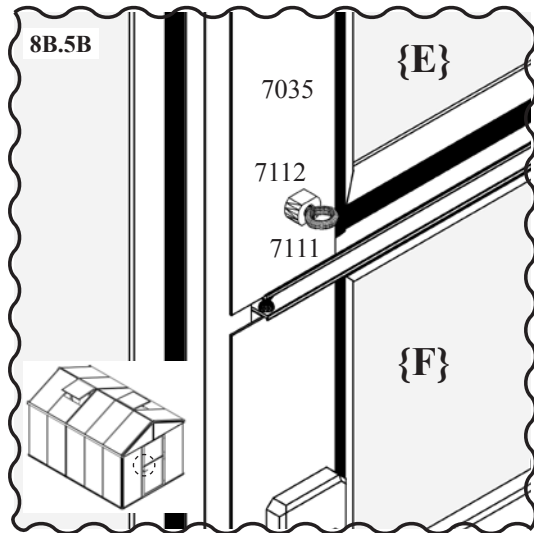
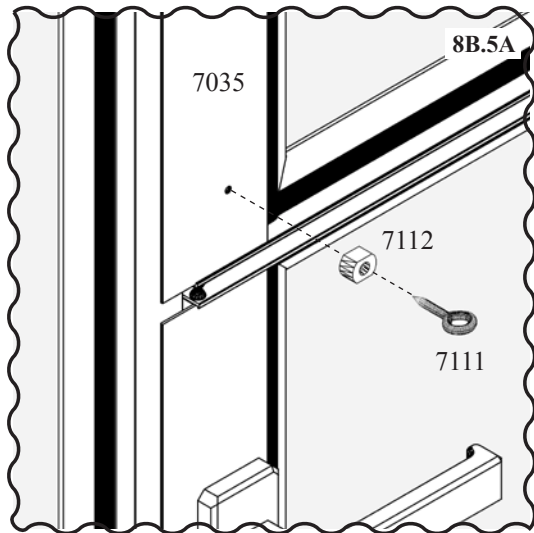

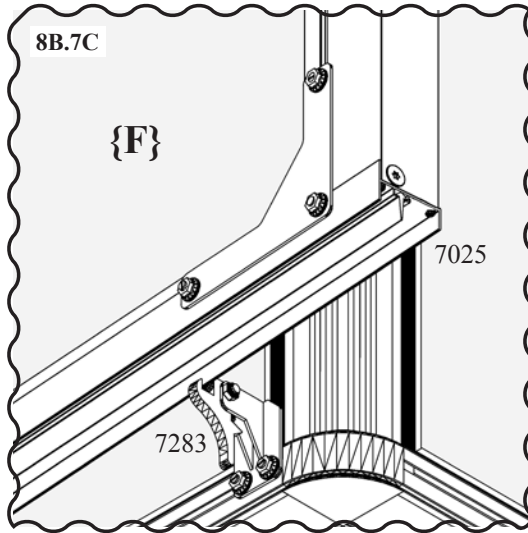

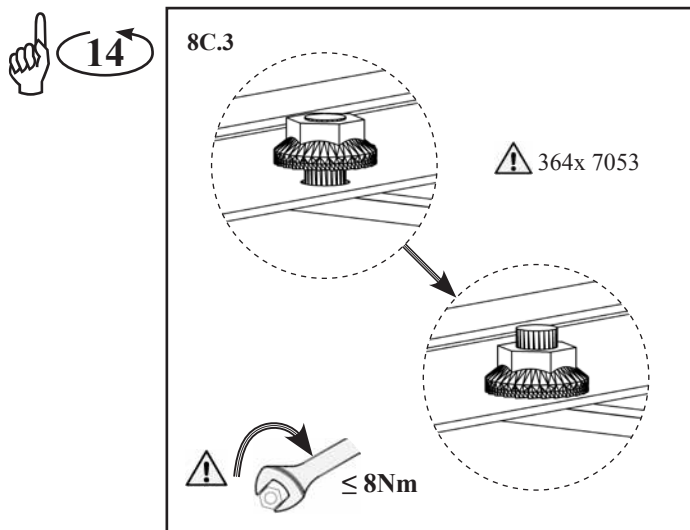
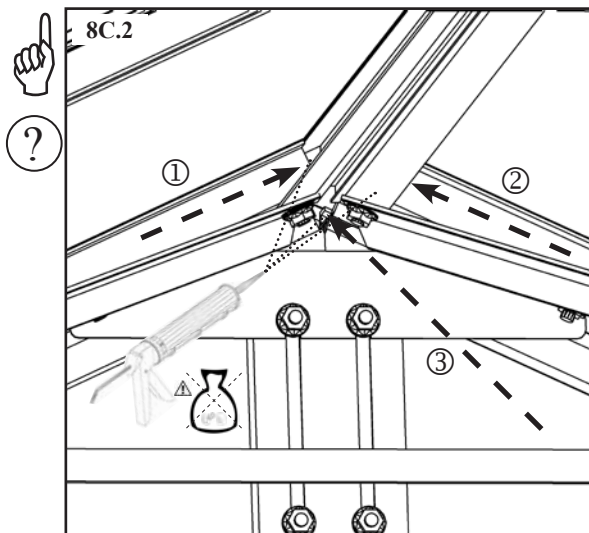
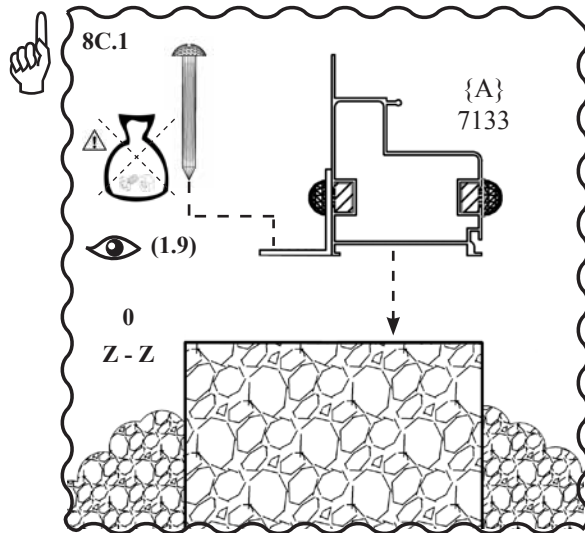

Important Tip
 Go to
 Not included in product!
 Alternative options
 Important!

9 - JRM, JRS,

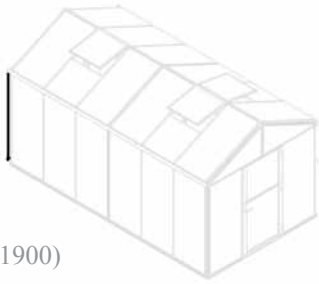

(11900)



DOWN PIPES, REGENFALLROHRE, TUYAUX DE DESCENTE, VALPIJPEN, NEDLØBSRØR, STUPRÖR, NEDLØPSRÖR, ALASLASKUPUTKET, TUBI DI SCARICO, SPÁDOVÉ TRUBKY, RURY SPUSTOWE, ODTOČNE CEVI, LEFOLYÓCSÖVEK, NIZ CSEVI, DONJE CJEVI, TËVI DE SCURGERE, ODTOKOVÉ RÚRY, ВОДОСТОЧНЫЕ ТРУБЫ, ВОДОСТІЧНІ ТРУБИ.

6200	8100	10000	11900	13800	15700	C9
1002 2x			Pack 1/1 - 1/6 ZE2			
1402 2x						
1403 2x						
1405 2x						
1409 2x						
1412 2x						
7349 2x						
1415 2x						
Pack 1/1 - 4/6						

{S8B}		-
1x		

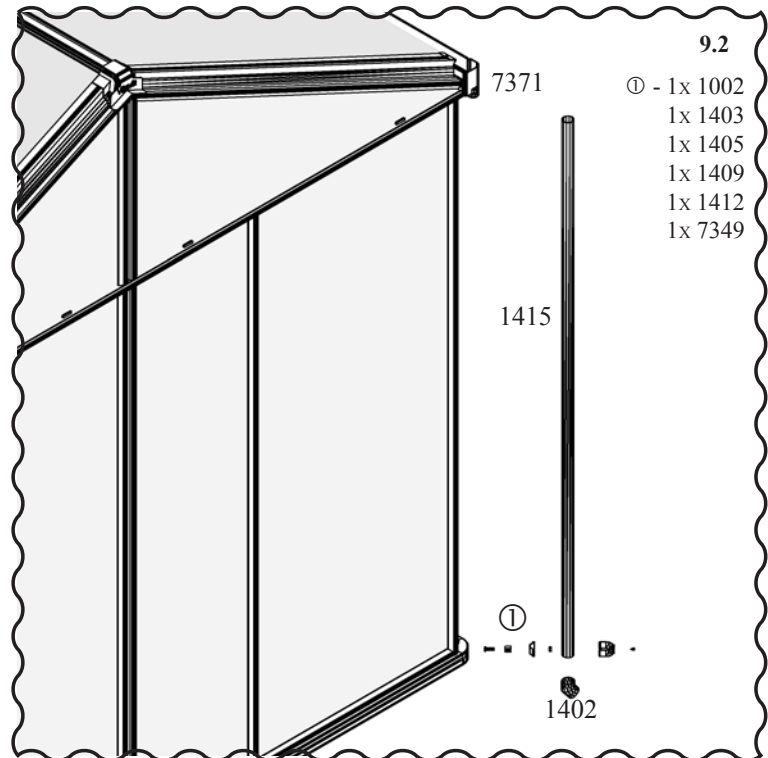
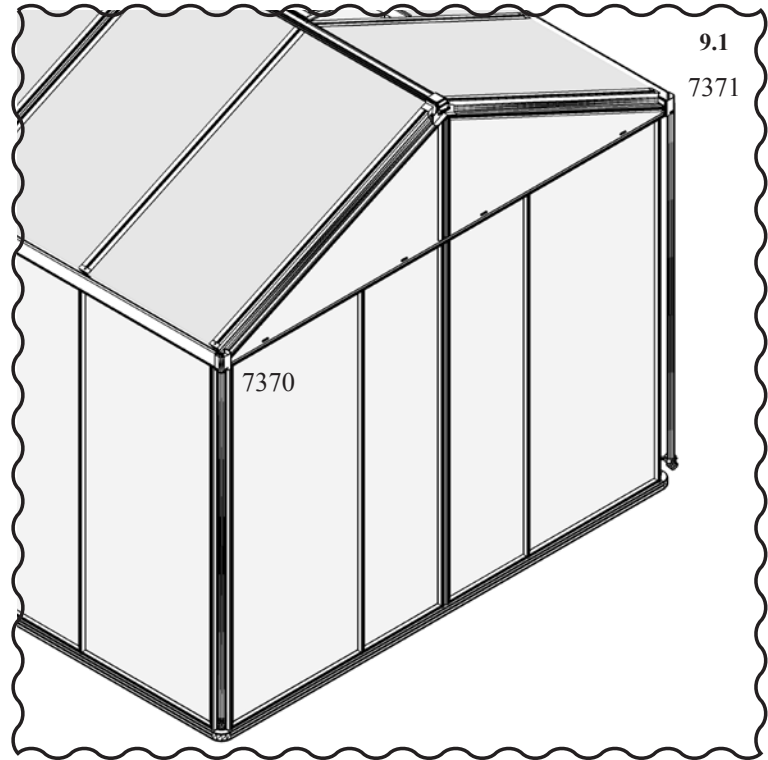
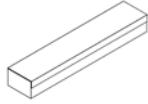

9 - JRM, JRS,

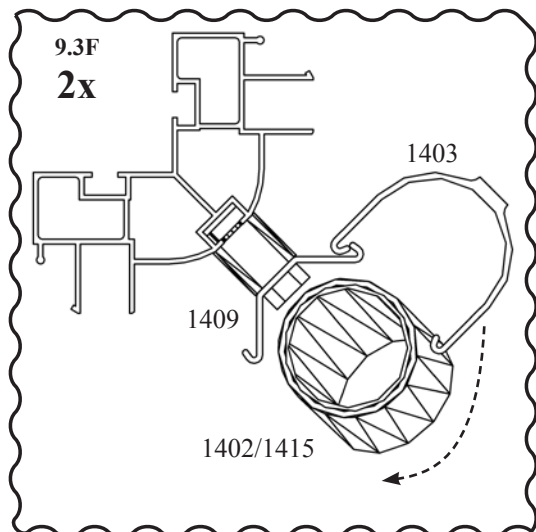
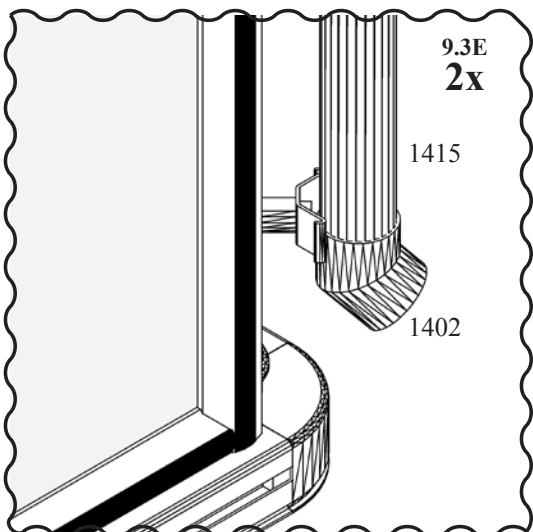
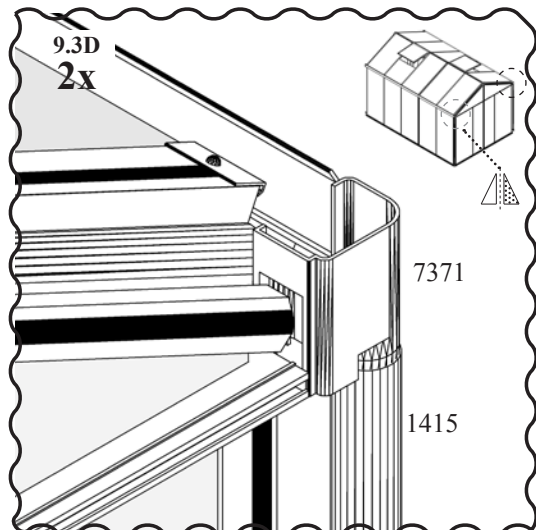
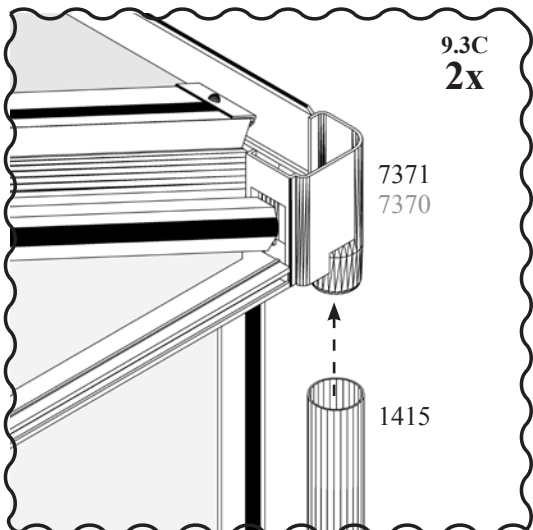
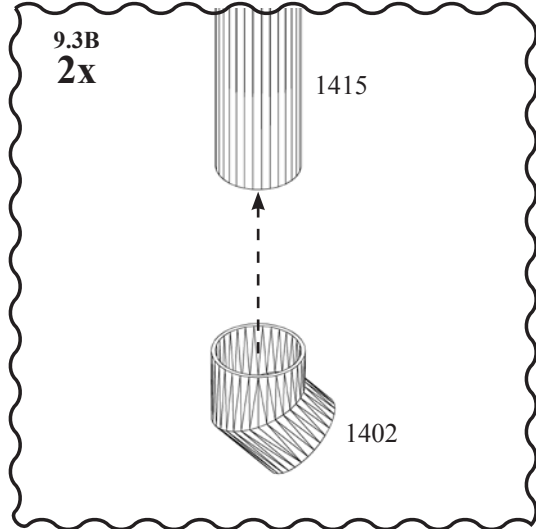
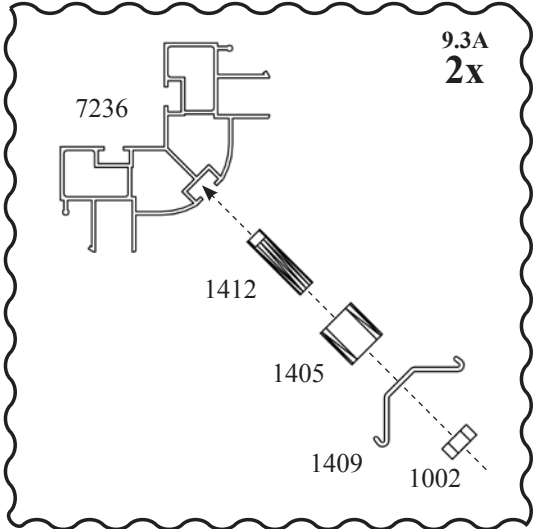

9 - JRM, JRS,

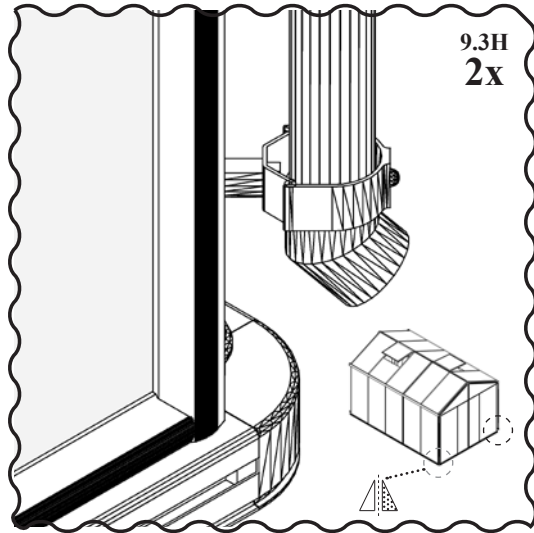
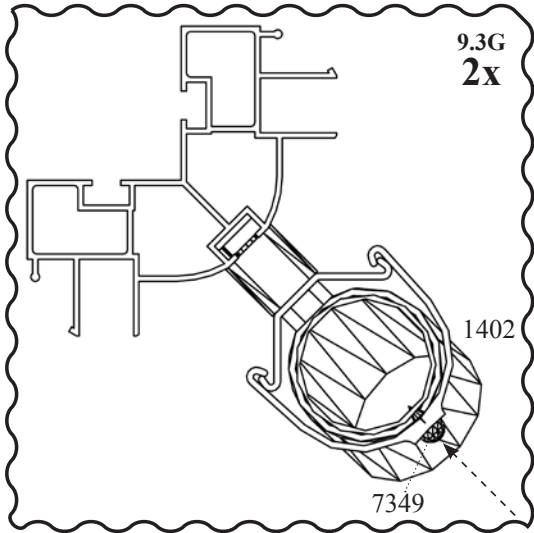

 Mirror of



E.P.H. Schmidt u. Co. GmbH
Hoefkerstrasse 30
44149 Dortmund
Postfach 170163
44060 Dortmund
Deutschland
Tel.: +49 231 941655 0
Fax: +49 231 941655 99
www.eph-schmidt.de
verkauf@eph-schmidt.de

OPJ A/S
Volderslevvej 36 A
5260 Odense S
Danmark
Tel.: +45 66 15 10 30
Fax: +45 66 15 00 84
www.opj.dk
opj@opj.dk