

# **(EN) Assembly instructions**

**(DE) Montageanleitung**

**(FI) Kokoonpano-ohjeet**

**(HR) Skupština Upute**

**(FR) Notice de Montage**

**(IT) Istruzioni di Montaggio**

**(BS) Skupština Uputstvo**

**(NL) Montage Instructies**

**(CS) Montážní Návod**

**(RO) Instrucțiuni de Asamblare**

**(DA) Montagevejledning**

**(PL) Instrukcja Montażu**

**(SK) Popis konštrukcie**

**(SV) Monteringsanvisning**

**(SL) Navodila za Montažo**

**(RU) Инструкция по Монтажу**

**(NO) Montasjeveiledning**

**(HU) Szerelési útmutató**

**(UK) Інструкція по монтажу**



**Vitavia**  
- makes living grow

**VM0023-S**  
**13000**



	<b>Contents Inhalt Indhold</b>	<b>Page Seite Side</b>
	Table of Contents Inhaltsverzeichnis Indholdsfortegnelse	3
	Symbols Symbole Symboler	4 - 5
	Carton part lists Kartonteilelisten Liste over indhold i kartonnen	6 - 13
	EN Safety Warning DE Sicherheitsvorkehrungen DA Sikkerhedsforskrifter EN,DE,FR,NL,DA,SV,NO,FI,IT,CS,PL,SL,HU,HR,BA,RO,SK,RU,UK	14 - 23
<b>S0</b>	Foundation / Steel Base Fundament / Stahlfundament Fundament / Stålsokkel	24 - 28
<b>S1</b>	Side Elements Seitenwände Sideelementer	29 - 41
<b>S2</b>	Plain Gable End Giebelende ohne Tür Gavle uden Dør	42 - 47
<b>S3</b>	Door Gable End Giebelende mit Tür Gavl med Dør	48 - 52
<b>S4</b>	Connecting the Separate Elements / Roof Zusammenbau der einzelnen Elemente / Dach Samling af de enkelte Elementer / Tag	53 - 67
<b>S5</b>	Double Door Doppeltür Dobbelte Skydedøre	68 - 81
<b>S6</b>	Roof Vents Dachfenster Tagvindue	82 - 85
<b>S7</b>	Glazing Verglasung Montering af Glas	86 - 87
<b>S8</b>	Down Pipes / Bolt Covers Regenablaufrohre / Kappen Nedløbsrør	88 - 91

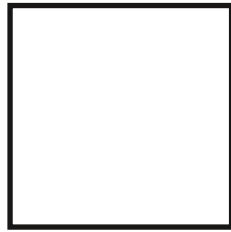

=

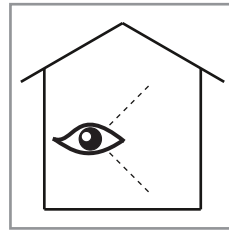

View from Inside  
Innenansicht  
Set indefra

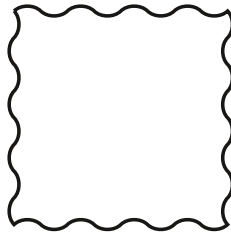

=

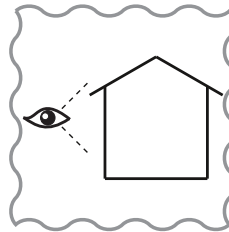

View from Outside  
Außenansicht  
Set udefra

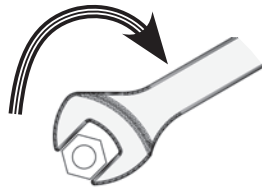

**1002**  
 $\leq 3Nm$



**3002**  
 $\leq 8Nm$

Max. tightening Torque  
Max. Drehmoment  
Maksimalt moment



Instructions  
Anleitung  
Instruktion



Look closely / go to  
Detail beachten / Siehe auch  
Observer nøje / Se også



Mirror of  
Spiegelung von  
Spejl af



Not included in product!  
Nicht im Lieferumfang enthalten!  
Indgår ikke i leverancen!



View from  
Blickrichtung  
Set fra



Outside  
Außenseite  
Uden for



Important!  
Achtung!  
Vigtigt!



Protected location!  
Windgeschützter Standort!  
Beskyttet placering!



Recycle  
Recyclbar  
Genbrugeligt



Important Tip  
Hinweis  
Vigtigt Tip



High Wind  
Bei starkem Wind  
Vind



Adjust by Hand  
Ohne Werkzeug  
Brug hænder



x Persons required  
x Erforderliche Personen  
x Personer, der kræves



Exactly square  
Absolut rechtwinklig  
Nøjagtig ret vinklet



Step for later  
Späterer Schritt  
Vises senere



Alternative options  
Alternativen  
Alternative muligheder



Not required  
nicht benötigt  
Ikke nødvendig



Incorrect!  
Falsch!  
Forkert!

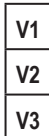

Version 1 to 3  
Variante 1 bis 3  
Version 1 til 3

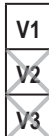

Version 1 only  
Nur Variante 1  
Kun version 1



**Pack Bundle System**  
**Bündelungssystem nach Aufbauschritten**  
**Bundnumre følger vejledningn**

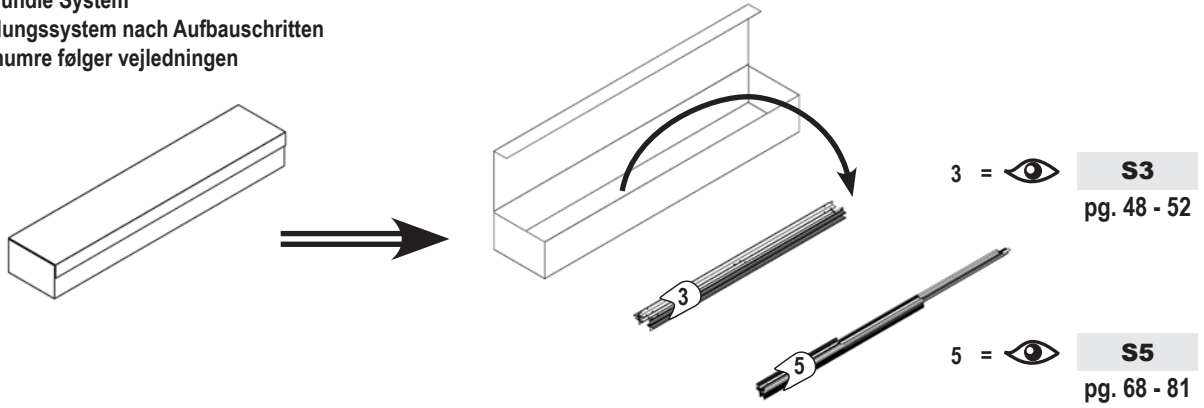

10mm



10mm



PH2



5 mm  
Metal



**Glazing Options**  
**Verglasung möglichkeiten**  
**Forskellige glas muligheder**

**PC**

Polycarbonate  
Hohlkammerplatten  
Kanal plader i polykarbonat

**FPG**

Full Pane Glass  
Ganze Scheiben  
Hele baner

**SPG**

Split Pane Glass  
Klinkerverglasung  
Delt glas

**FRG**

Frosted Pane Glass  
Nörpelglas  
Uigennemsigtigt glas



Persons required.



Important!



Go to







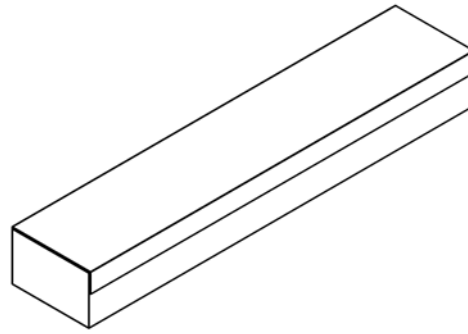

Not included in product!



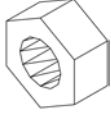
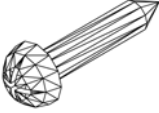
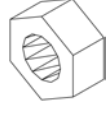



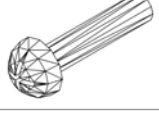
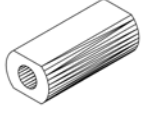

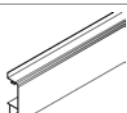
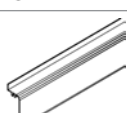
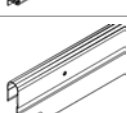
**VM0023-S**  
13000

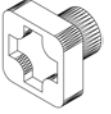

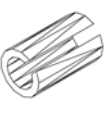

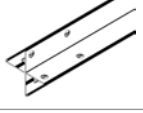
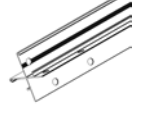
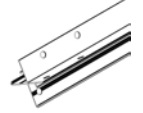

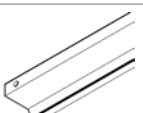
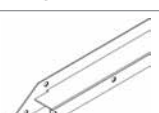
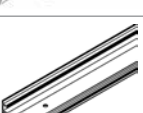

= 7x

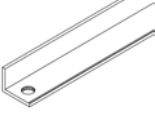



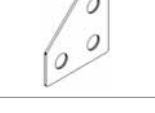

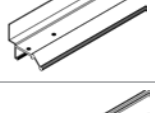
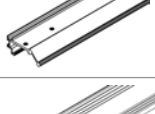
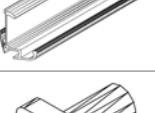
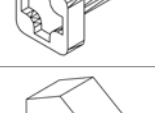
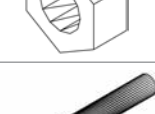



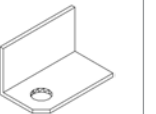
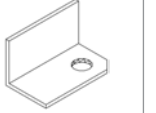

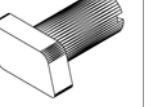

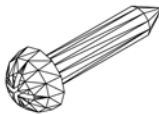
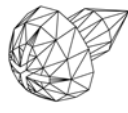

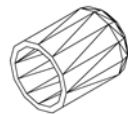
Model: VM0023-S		
		<b>13000</b>
<b>1/7</b>	JUP,URA, 1/4_SIR, 1/6 Front SL	1x
<b>2/7</b>	SIR,SLT,SSD, 2/6	1x
<b>3 &amp; 4 / 7</b>	JUP,URA, 3/4_PHX,PSD, 3/5_SIR,SLT,SSD, 3/6 Back	2x
<b>5/7</b>	SIR,SLT,SSD, 4/6	1x
<b>6/7</b>	SIR,SLT,SSD, 5/6 Base	1x
<b>7/7</b>	SIR,SLT,SSD, 6/6	1x
		<b>7x</b>





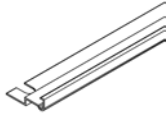

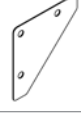
JUP,URA, 1/4 _SIR, 1/6 Front SL				
Item No.	Part	Sect. Ref.	Size mm	Quantity
1002		5_2	M6	2x
1003		5_1 8	3.5 x 16	32x
1007		5_1	M4	4x
1009		5_1	Ø8/4	4x
1014		5_1	20	4x
1015		5_1	Ø22	4x
1043		3	170	2x
1304		5_1	M4 x 18	4x
1310		5_2	30.4	2x
1347		5_2	1257	2x
1359		5_1	621	2x
1360		5_1	621	2x
1361		5_1	621	4x
1362		5_1	613	2x



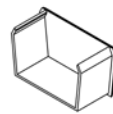
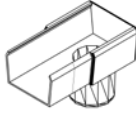
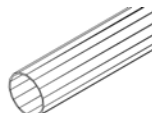
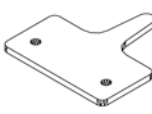

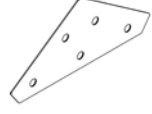
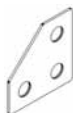
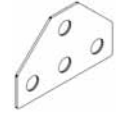

JUP,URA, 1/4 _SIR, 1/6 Front SL				
Item No.	Part	Sect. Ref.	Size mm	Quantity
1500		5_1	M6 x 5	2x
1515		5_1	M6	2x
2005		5_1L	100	1x
2006		5_1L	10	2x
2021	 Nylon	5_1	1923	2x
2036		3	1511	2x
2039		3	1536	1x
2040		3	1536	1x
2041		3	1963	1x
2042		3	1963	1x
2043		5_2	416	2x
2046		3	2484	1x
2048		3	1318	1x
2058		5_1	1923	2x

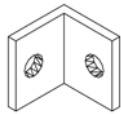
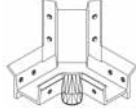



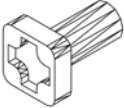
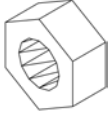
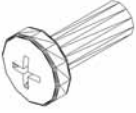

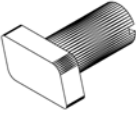

JUP,URA, 1/4 _SIR, 1/6 Front SL				
Item No.	Part	Sect. Ref.	Size mm	Quantity
2075		3	1575	1x
2076		3	1575	1x
2089		3	619	1x
2090		3	619	1x
2091		3	175	1x
2092		3	37	2x
2094		3	426	1x
2096		3	619	2x
2098		5_1L	1923	1x
2099		5_1R	1923	1x
2100		3	425	1x
3001		5	M6 x 12	13x
3002		5	M6	14x
4201		5_2	M6 x 45	2x

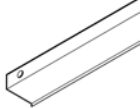

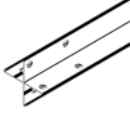
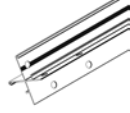
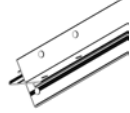



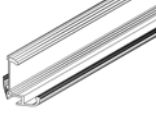

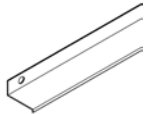

JUP,URA, 1/4 _SIR, 1/6 Front SL				
Item No.	Part	Sect. Ref.	Size mm	Quantity
5001		5_2	33	1x
5002		5_2	33	1x
6060		5_2	Ø12/6	2x
7399		5_2	M6 x 12	1x





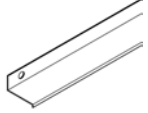
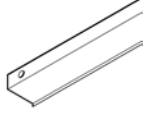

SIR,SLT,SSD, 2/6				
Item No.	Part	Sect. Ref.	Size mm	Quantity
1003		5_1 8	3.5 x 16	2x
1006		6 8	3.5 x 6	25x
1018		4_2	43.9	12x
1019		6_1	15	4x
1020	PVC 	4_2 7	160000	1x
1043		2	170	4x
1063		6_2	635	4x
1064		6_1	602	4x
1065		6_1	520	8x
1066		6_1	602	4x
1067		6_1	295	4x
1092		1 4_1 4_2	120	18x
1402		8	36	3x
1403		8	20	1x

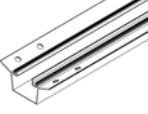
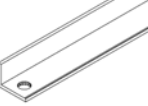

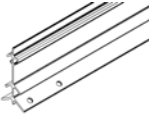

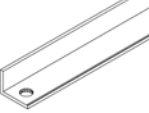
SIR,SLT,SSD, 2/6				
Item No.	Part	Sect. Ref.	Size mm	Quantity
1404		8	20	5x
1408		8	75	1x
1413		8	1470	3x
2016		6_2	40	8x
2055		1 4_2	1511	14x
2056		1	255	7x
2091		2	175	2x
2092		1	37	4x
2093		2	56	2x
2500		1_2	1507	2x
2513		4_2	1490	2x
2514		4_2	1490	2x
2519		4_2	24	2x
2520		1_2	178.5	2x

SIR,SLT,SSD, 2/6				
Item No.	Part	Sect. Ref.	Size mm	Quantity
2521		8	47	2x
2527		1_1 2	Ø18/6	6x
3001		0 - 4 6	M6 x 12	365x
3002		0 - 4 6	M6	374x
3003		4_2	M6 x 16	1x
3057		4_2	841	7x
7399		6_2	M6 x 12	8x
9002		4_3	19	32x
9004		0_2	Ø16/6.5	4x

JUP,URA, 3/4_PHX,PSD, 3/5_SIR,SLT,SSD, 3/6 Back				
Item No.	Part	Sect. Ref.	Size mm	Quantity
2022		2	2484	1x
2033		2	1898	2x
2035		2	2476	1x
2036		2	1511	2x
2039		2	1536	1x
2040		2	1536	1x
2041		2	1963	1x
2042		2	1963	1x
2054		2	1318	1x
2100		2	425	1x
2101		2	1963	1x

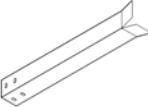
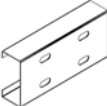

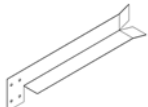
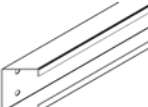
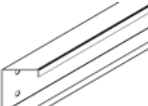
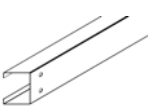
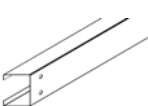



SIR,SLT,SSD, 4/6				
Item No.	Part	Sect. Ref.	Size mm	Quantity
2024		1_1	3728	1x
2029		1_1	3728	1x
2033		1_1 4_2	1898	4x
2049		1_2	1575	2x
2501		4_1	556	1x
2502		4_1	556	1x
2503		4_1	622	1x
2504		4_1	622	1x
2505		1_2	1244	1x
2506		1_2	1244	1x
2507		1_2	1178	1x
2508		1_2	1178	1x
2509		4_2	1978	2x
2510		4_1	1577.5	2x

SIR,SLT,SSD, 4/6				
Item No.	Part	Sect. Ref.	Size mm	Quantity
2511		4_2	3728	1x
2512		4_2	2485	1x
2515		4_2	731	2x
2516		4_2	731	2x
2517		4_2	1885	1x
2518		4_2	1885	1x
2526		1_1	3714	1x
4279		2	2470	2x

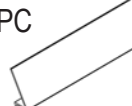
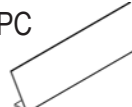
SIR,SLT,SSD, 5/6 Base				
Item No.	Part	Sect. Ref.	Size mm	Quantity
9101		0_2	455	6x
9103		0_2	125	1x
9106		0_2	50	8x
9107		0_2	455	1x
9116		0_2	2544	3x
9121		0_2	1894	2x
9138		0_2	652	2x
9139		0_2	1274	2x
9140		0_2	455	2x

SIR,SLT,SSD, 6/6 *				
Item No.	Part	Sect. Ref.	Size mm	Quantity

\* Included with Glazing

6515	PC 	7	1960	14x
6516	PC 	7	1509	52x
6517	PC 	7	970	8x
6518	PC 	7	731	8x
6519	PC 	7	610	8x
6520	PC 	7	540	4x
6521	PC 	7	425	6x



1. PLEASE READ THESE INSTRUCTIONS CAREFULLY AND COMPLETELY BEFORE ASSEMBLING YOUR GREENHOUSE.
2. Sharp edges and corners can cause injury. Always wear protective glasses, gloves, shoes and headgear when handling the aluminium profiles, glass and polycarbonate sheets. Broken glass is a safety hazard – always clear up immediately and dispose of with care.
3. The product you have purchased is intended only for growing plants and should only be used for this purpose. When used for other purposes we will take no responsibility.
4. It is recommended that this greenhouse is assembled by two people.
5. Should you encounter difficulties constructing this house, or in fitting the glass or polycarbonate sheets, please contact your retailer  
– **do not use force!**
6. The greenhouse must always be anchored.

**SITE SELECTION** : Always try to select a sunny location, sheltered from the wind as much as possible.

**IMPORTANT** : Before assembling your new greenhouse, please check that all parts in the provided list are included. Please take each bundle out of the packaging in order to identify the parts better. It is important that the opened bundles do not get mixed with one another.

If something is missing please contact your retailer.

 = Is not included in carton!

Diagrams in a single frame show the view from inside the greenhouse. Those enclosed in a wavy frame show the view from outside the greenhouse.

**Nuts - Max. tightening torque (1002) 3 Nm / (3002) 8 Nm.**



**MAINTENANCE** : The greenhouse should be thoroughly washed with a gentle detergent occasionally. Please check that the detergent used does not react aggressively with aluminium.

Ensure that the door tracks are cleaned regularly to avoid a build up of debris.

**0. BASE** : **Important!** The base must be exactly square and level.

Foundations must extend down below the frost level.

**FINISHING** : Place the warning label inside the house.

For plant breeding sealed joints are not necessary. If desired, it is possible to seal the greenhouse at the edges using neutral silicone. Silicone is not included.  

A full range of accessories is available to help you make the most of this product. Please contact your local stockist for details.

**SAFETY NOTICE** : Do not climb onto the roof surfaces. There is a danger of falling.

In the event of high winds, close all doors and vents.

In the event of heavy snowfall, clear the roof of the building or take suitable measures to support the roof. Heat the building in winter.

**COMMENTS** : For the complete protection of your new greenhouse, we advise you to include it in your house insurance. Please take note of possible building rules relating to the positioning of greenhouses.

Please stick the greenhouse model label provided onto the part (1359) after successfully assembling this product. This information is important in the event that replacement parts are later required. Please keep these Assembly Instructions in a safe place, for future reference!

Our policy is one of continuous improvement and we reserve the right to change the specifications without prior notice.



**Choking Hazard -  
Contains small parts**

1. **BITTE LESEN SIE DIESE MONTAGEANLEITUNG VOR BEGINN DES AUFBAUS KOMPLETT DURCH!**
2. Bei der Handhabung von Glas, Polycarbonatplatten oder Gewächshausteilen sind immer eine Schutzbrille, Handschuhe, Sicherheitsschuhe und ein Kopfschutz zu tragen, da scharfe Kanten zu Verletzungen führen können. Gebrochenes Glas ist ein Sicherheitsrisiko. Beseitigen Sie es mit der gebotenen Vorsicht.
3. Das von Ihnen erworbene Produkt ist für die Aufzucht von Pflanzen konstruiert und sollte auch ausschließlich dafür genutzt werden. Bei anderweitiger Nutzung ist jegliche Haftung ausgeschlossen.
4. Für die Montage dieses Produktes sind zwei Personen erforderlich.
5. Sollten Sie beim Montieren des Hauses oder beim Einsetzen der Verglasung Schwierigkeiten haben, dann setzen Sie sich bitte mit Ihrem Händler in Verbindung  
– **Wenden Sie keine Gewalt an!**
6. Das Gewächshaus muss verankert werden.

**STANDORTWAHL** : Suchen Sie den sonnigsten, aber gleichzeitig einen windgeschützten Platz aus.

**WICHTIG** : Bevor Sie mit der Montage Ihres Gewächshauses beginnen, überprüfen Sie, ob alle in der Liste aufgeführten Teile vorhanden sind. Nehmen Sie die einzelnen Bündel aus der Verpackung, um sie besser identifizieren zu können. Es ist wichtig, dass die geöffneten Bündel nicht durcheinander geraten.

Fehlt etwas, dann setzen Sie sich bitte mit Ihrem Lieferanten in Verbindung.

 = Gehört nicht zum Lieferumfang!

**Alle Zeichnungen sind von der Innenseite des Hauses gesehen abgebildet, mit Ausnahme der Abbildungen, die in einem gewellten Rahmen dargestellt sind. Diese beschreiben die Außenansicht.**



**Muttern mit max. (1002) 3 Nm / (3002) 8 Nm anziehen.**

**WARTUNG** : Das Gewächshaus sollte hin und wieder gründlich mit einer neutralen Waschmittellauge abgewaschen werden. Das Glas kann mit einem Reinigungsmittel gesäubert werden, das weder Kunststoffteile, noch den Aluminiumrahmen angreift. Reinigen Sie regelmäßig die Türlaufschiene.

**0. FUNDAMENT** : **Wichtig!** Das Fundament muss absolut rechtwinklig und eben sein.

Das Fundament muss frostfrei gegründet werden.

**DIE LETZTEN HANDGRIFFE** : Den beiliegenden Warnungsaufkleber von innen aufkleben.

Zur Pflanzenaufzucht sind abgedichtete Fugen nicht notwendig. Sollten sie dies dennoch wünschen, empfiehlt sich, das Gewächshaus an den vorhandenen Fugen mit neutral vernetzendem Silikon abzudichten. Das Silikon gehört nicht zum Lieferumfang.  

Ihr Lieferant hält ein reichhaltiges Sortiment an Gewächshaus-Zubehör für Sie bereit. Sprechen Sie ihn an.

**SICHERHEITSHINWEIS** : Die Dachflächen dürfen nicht betreten werden. Es besteht Absturzgefahr.

Bei starkem Wind sollten alle Öffnungen und die Tür geschlossen werden.

Dächer von Gewächshäusern sind so rechtzeitig von Schnee zu räumen, dass keine gefährliche Schneebelastung eintreten kann.

**ANMERKUNGEN** : Zum vollen Schutz des Gewächshauses empfehlen wir, es mit in Ihre **Hausversicherung** einzuschließen. Beachten Sie eventuell vorhandene örtliche Bauvorschriften.

Den mitgelieferten Typaufkleber nach erfolgter Montage des Gewächshauses auf das Teil (3511) kleben. Die Typbezeichnung benötigen

Sie zur Angabe bei der Bestellung evtl. benötigter Ersatzteile. Bitte heben Sie die Montageanleitung auf!

Alle Maßangaben sind Annäherungswerte. Änderungen vorbehalten.



**Erstickungsgefahr -  
Enthält Kleinteile**

1. **MERCI DE LIRE CES INSTRUCTIONS INTEGRALEMENT AVEC ATTENTION AVANT DE COMMENCER LE MONTAGE !**
2. Toujours porter des lunettes et des gants de protection, des chaussures de sécurité et un casque lors de la manipulation du verre, des panneaux en polycarbonate ou des éléments de la serre étant donné que les rebords coupants peuvent sinon provoquer des blessures. Le verre brisé constitue un risque. Merci de l'éliminer avec la prudence qui s'impose.
3. Le produit que vous venez d'acquérir a été conçu pour la culture de plantes et doit être utilisé exclusivement dans cet objectif. Nous excluons toute responsabilité en cas d'autre utilisation.
4. Deux personnes sont nécessaires pour réaliser le montage de ce produit.
5. Si vous deviez rencontrer des difficultés lors du montage de la structure ou de l'installation du vitrage, merci de contacter votre revendeur  
– **N'ayez pas recours à la force !**
6. La serre doit être ancrée.

**CHOIX DE L'EMPLACEMENT :** Choisissez l'emplacement le plus ensoleillé mais aussi le mieux protégé du vent.

**IMPORTANT :** Avant de commencer le montage de votre serre, vérifiez que vous disposez de toutes les pièces telles qu'elles sont indiquées dans la liste. Retirez les différents paquets de l'emballage pour mieux les identifier. Il est important de ne pas mélanger les paquets ouverts.

Si un composant manque, merci de contacter votre revendeur.

 = N'est pas comprise dans la livraison!

Tous les schémas représentent la vue de l'intérieur de la construction exception faite des illustrations imprimées dans un cadre ondulé. Elles décrivent alors une vue de l'extérieur.

**Serrer les écrous avec (1002) 3 Nm / (3002) 8 Nm maxi.**

**MAINTENANCE :** La serre doit être nettoyée de temps en temps à fond avec une lessive neutre. Les vitres peuvent être nettoyées avec un produit qui n'attaque ni les pièces en plastique ni le cadre en aluminium ni les pinces à ressort des vitres. Nettoyez régulièrement le rail de la porte.

**0. FONDATION : Important !** Les fondations doivent être parfaitement perpendiculaires et planes. Des fondations en acier galvanisé sont disponibles comme accessoires pour tous les modèles de serre.

Les fondations doivent être à l'abri du gel.

**LES DERNIERS GESTES :** Coller l'autocollant d'avertissement ci-joint à l'intérieur.

Si vous le souhaitez, vous pouvez colmater les joints existants sur votre serre avec de la silicone. Cette silicone n'est pas comprise dans la livraison. 

otre fournisseur tient une vaste gamme d'accessoires pour serres à votre disposition. Contactez-le.

**CONSIGNES DE SÉCURITÉ :** Ne montez pas sur les surfaces du toit. Il y a un risque de chute.

En cas de vent fort, toutes les ouvertures et toutes les portes doivent être fermées.

Les toits des serres doivent être rangés à temps avant la chute de neige de manière à éviter toute charge dangereuse due à la neige.

**REMARQUES :** Pour protéger votre serre au maximum, nous recommandons de l'inclure à votre couverture d'assurance ménagère. Prenez en compte les éventuelles réglementations locales en vigueur.

Coller l'autocollant signalétique fourni sur la partie (1359) une fois le montage terminé. Vous aurez besoin de cette désignation pour commander d'éventuelles pièces de rechange. Merci de conserver les instructions de montage !

Toutes les dimensions indiquées sont des valeurs approximatives. Sous réserve de modifications.

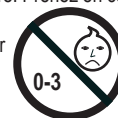

**Risque d'étouffement -  
Contient de petites  
pièces**

1. **LEEST U EERST DE GEHELE INSTRUCTIES DOOR ALVORENS TE BEGINNEN MET DE OPBOUW VAN DE KAS.**
2. Draag altijd handschoenen als u met glas, polycarbonaat platen of aluminium werkt, deze kunnen scherpe hoekjes en/of randen hebben die tot verwondingen kunnen leiden. Indien glas gebroken is dient u het veilig en meteen op te ruimen.
3. Het product dat u heeft gekocht is alleen bestemd voor het kweken van planten. Wanneer deze voor andere doeleinden zal worden gebruikt dragen wij hier geen verantwoordelijkheid voor.
4. Wij raden u aan de kas met twee personen in elkaar te zetten.
5. Mocht u problemen hebben het glas of polycarbonaat platen in te passen, neem dan contact op met uw leverancier. **Gebruik geen geweld.**
6. De kas moet altijd worden verankerd.

**KIEZEN PLAATS :** Probeer altijd een zonnige plaats te kiezen die zoveel mogelijk tegen wind beschermt is.

**BELANGRIJK :** Controleer a.u.b. of u alle onderdelen op de meegeleverde lijst hebt voordat u begint aan het in elkaar zetten van uw nieuwe kas. Haal a.u.b. elk pakket uit de doos om de onderdelen beter te identificeren. Het is belangrijk dat de open pakketten niet door elkaar gehaald worden.

Als er onderdelen ontbreken, neem dan a.u.b. contact op met uw leverancier.

 = Deze is niet inbegrepen!

**Op de tekeningen met het enkelvoudige frame wordt de binnenkant van de kas getoond. Op de tekeningen met het golvend frame wordt de kas van de buitenkant bekeken.**

**Moertjes - Max. aanhaalmoment (1002) 3 Nm / (3002) 8 Nm.**

**ONDERHOUD :** Om uw kas schoon te houden dient deze af toe grondig gereinigd te worden met een zacht reinigingsmiddel. Zorg er a.u.b. voor dat het reinigingsmiddel niet het aluminium aantast of de beglazingsclips.

Om te voorkomen dat zich vuil ophoopt in de deurrails, zal men deze regelmatig moeten schoonmaken.

**0. FUNDERING : Belangrijk!** Let op dat de fundering haaks en waterpas staat.

**AFWERKING :** Plaats het waarschuwingslabel aan de binnenkant van de kas.

Als u uw kas wilt afdichten, doe dit dan met siliconenkit. (deze is niet inbegrepen). 

Een geheel assortiment van kassen accessoires is verkrijgbaar bij uw leverancier. Voor meer informatie kunt u contact opnemen met uw leverancier.

**VEILIGHEIDSRREGELS :** Klim niet op de dakvlakken. Er bestaat gevaar voor vallen.

Bij zware wind, sluit altijd alle deuren en ramen.

Bij zware sneeuwval, moet u altijd het dak vrij houden of zorgen voor een goede ondersteuning van het dak, tegen de druk van de sneeuw. Verwarm de kas in de winter.

**COMMENTAAR :** Voor de gehele bescherming van uw nieuwe kas, raden wij u aan om deze op te nemen in uw verzekering. Denk er ook aan dat de kas aan alle bouwweisen moet voldoen, houd u ook rekening met de plaats van de kas.

Plakt u alstublieft het kasmodel sticker op het onderdeel (1359) nadat de kas succesvol is geïnstalleerd. Deze informatie is belangrijk voor het vervangen van onderdelen in de toekomst. Bewaar de instructies op een veilige plek zodat u deze nog altijd kunt nalezen.

Ons beleid is gebaseerd op het continu verbeteren van onze producten, hierdoor behouden wij ons het recht om modellen te veranderen zonder verdere berichtgeving.



**Verstikking -  
Bevat kleine onderdelen**

DA

## Sikkerhedsforskrifter / Montage

- VENLIGST LÆS DENNE MONTAGEVEJLEDNING INDEN DE GÅR I GANG MED SAMLING AF DERES DRIVHUS.**
- Når De arbejder med glas eller polykarbonat, skal De altid bruge handsker. Skarpe kanter kan forårsage skader. Også skarpe kanter eller hjørner på aluminiumsprofiler kan forårsage skader – brug derfor også altid handsker ved montering af disse.
- Dette produkt er konstrueret som et drivhus beregnet til planteavl og er som sådan ikke konstrueret til at være helt tæt, da det er nødvendigt med udluftning bl.a. for at undgå kondensdannelse. Såfremt De ønsker at anvende drivhuset som et "uderum/stue" eller lignende, gør vi udtrykkeligt opmærksom på, at drivhuset ikke er 100 % vandtæt, og at vi ikke påtager os noget ansvar for eventuelle skader på løsøre el. lign., der er anbragt i drivhuset.
- Til montage af dette produkt kræves 2 personer.
- Skulle De få problemer med drivhusmontagen eller med glasisætningen, bedes De sætte Dem i forbindelse med Deres forhandler – anvend ikke vold!
- Den vedlagte selvklæbende identifikationsetiket anbringes indvendigt i drivhuset – f.eks. indvendig på døren eller lign. Oplysningerne på etiketten vil gøre det meget lettere for Dem at fremskaffe reservedele, såfremt dette skulle blive aktuelt.

Vi ønsker Dem god arbejdslyst og håber, at De får rigtig mange gode stunder med og i Deres Vitavia drivhus.

**PLACERING** : Vælg et solrigt sted, hvor der er mest mulig læ. Vær endvidere opmærksom på, at ved placering i nærheden af høje bygninger, træer mv. kan der opstå turbulens ved kraftig blæst. En sådan placering bør derfor undgås.

**VIGTIGT** : Før De begynder at samle Deres drivhus, kontroller venligst efter indholdsfortegnelsen, at alle dele er medleveret. Tag de enkelte bundter ud af kassen for bedre at kunne kontrollere indholdet. Det er vigtigt ikke at blande de åbnede bundter.

Hvis der mangler noget, kontakt venligst Deres forhandler.

 = Indgår ikke i leverancen!

**Alle tegninger af drivhuset er set indefra undtagen de tegninger, hvor der er en bølget ramme udenom. Disse er set udefra.**

**NB!** Såfremt De anvender en akku-maskine til samling af bolte og møtrikker, må momentet maksimalt være (1002) 3 Nm / (3002) 8 Nm.

**VEDLIGEHOLDELSE** : Drivhuset bør lejlighedsvis vaskes grundigt med et mildt vaskemiddel. Glasset kan rengøres med et hvilket som helst rengøringsmiddel, der ikke skader aluminiumsprofiler eller glasklemmer.

**0. FUNDAMENT** : **Vigtigt!** Sørg for sokkelen er i vinkel og vandret.

**FÆRDIGGØRELSE** : Hvis De ønsker at gøre Deres drivhus helt tæt, anvend silikone (ikke inkluderet) i alle samlinger. 

Et stort udvalg af tilbehør, der passer til dette drivhus, kan fås hos Deres forhandler. Tilbehøret kan ses på vor hjemmeside [www.vitavia.dk](http://www.vitavia.dk)

**SIKKERHEDSANVISNING** : Du må ikke klatre op på tagfladerne. Der er fare for at falde ned.

I tilfælde af stormvarsel, luk alle oplukkelige vinduer og døre.

I tilfælde af kraftigt snefald, ryd drivhusets tag og træf passende foranstaltninger til at understøtte taget.

**ANMÆRKNINGER** : Vi anbefaler, at De sørger for, at Deres husforsikring også dækker Deres drivhus. Overhold alle byggevedtægter. Kontakt Teknisk Forvaltning i Deres kommune, hvis De er i tvivl.

Den vedlagte selvklæbende identifikationsetiket anbringes indvendigt i drivhuset – f.eks. indvendig på døren eller lign. Oplysningerne på etiketten vil gøre det meget lettere for Dem at fremskaffe reservedele, såfremt dette skulle blive aktuelt. Typebetegnelsen skal De bruge ved bestilling af evt. reservedele, så venligst opbevar montagevejledningen til senere brug.

Vi forbeholder os ret til uden varsel at foretage løbende produktjusteringer. På vor hjemmeside [www.vitavia.dk](http://www.vitavia.dk) vil De altid kunne downloade den nyeste manual, som derfor kan afvige lidt fra Deres produkt. Manualens udgave kan identificeres ved hjælp af den talkode, der er trykt nederst på hver side i manualen. Alle målangivelser er ca.-mål.

Vi ønsker Dem god arbejdslyst og håber, at De får rigtig mange gode stunder med og i Deres Vitavia drivhus.



**Kvælningsfare -  
Indeholder små dele**

SV

## Säkerhetsinstruktioner / Monteringsanvisning

- VÄNLIGEN LÄS DENNA MONTERINGSANVISNING INNAN NI BÖRJAR MONTERA VÄXTHUSET.**
- När ni arbetar med glas eller polykarbonat, skall ni alltid använda handskar. Vassa kanter kan förorsaka skador. Även vassa kanter eller hörn på aluminiumprofiler kan förorsaka skador – använd därför alltid handskar vid montering av dessa.
- Produkten ni har köpt är konstruerad för plantodling och skall uteslutande användas till detta. Vid annan användning bortfaller producentens ansvar.
- Till montering av denna produkt krävs 2 personer.
- Skulle ni få problem med monteringen eller glasisättningen, ombedes ni kontakta återförsäljaren – använd inte våld!
- Den bifogade självhäftande identifieringsetiketten fästes invändigt i växthuset. Upplysningarna på etiketten gör det mycket lättare för er att i framtiden skaffa reservdelar om detta skulle bli aktuellt.

Vi hoppas ni får många trevliga stunder med och i erat Vitavia växthus.

**PLACERING** : Välj en solig plats med mesta möjliga solljus på taket. Välj en plats som är skyddad mot vind så mycket som möjligt.

**VIKTIGT** : Innan monteringen av växthuset påbörjas, bör delarna kontrolleras mot detaljförteckningen. För att kunna identifiera delarna skall de packas upp ur lådan.

Det är viktigt att de öppnade buntarna inte blandas samman.

Om något saknas kontakta din återförsäljare.

 = Ingår inte i leveransen!

**Alla bilder på växthuset är visade inifrån med undantag från de bilder som har vågig ram runt sig, dessa är visade utifrån.**

**Muttrar får ej dras åt för hårt, max (1002) 3 Nm / (3002) 8 Nm.**

**UNDERHÅLL** : För att hålla växthuset rent skall det då och då tvättas med en svag lösning av diskmedel. Glaset kan göras rent med något rengöringsmedel som inte skadar aluminiumprofilerna eller glasklämmorna.

**0. GRUND** : Kontrollera att grunden är i vinkel och vågrät.

**FÄRDIGSTÄLLNING** : Om ni önskar växthuset tätt skall silikon fogmassa (medföljer ej) sättas på alla fogar. 

Ett fullständigt sortiment tillbehör passande detta växthus kan erhållas från återförsäljaren.

**SÄKERHETSFORESKRIFTER** : Klättra inte upp på takytorna. Det finns risk för fall.

Om fara för storm så skall alla takventilationer och dörrar stängas.

Vid kraftigt snöfall bör taket rensas från snö.

Vi föreslår att växthuset ingår i hemförsäkringen. Följ gällande byggregler vid uppförande av växthus.

Klistra dekalen med växthusmodell på dörrskena (1359) efter färdigställande av växthuset.

Denna information är viktig vid beställning av tillbehör och reservdelar.



**Kvævningsrisik -  
Innehåller små delar**



## Sikkerhedsforanstaltninger / Montasjeveiledning

1. **VENNLIGST LES DENNE MONTERINGSANVISNINGEN FØR DE BEGYNNER MONTERINGEN AV DERES VEKSTHUS.**
2. Når De arbeider med glass eller polycarbonat skal De alltid benytte hansker. Skarpe kanter kan forårsake skader. Også skarpe kanter eller hjørner på aluminiumsprofiler kan forårsake skader – bruk derfor alltid hansker også ved montering av disse.
3. Produktet De har kjøpt, er konstruert til vekst av planter og skal utelukkende benyttes til dette. Ved annen type bruk bortfaller enhver form for reklamasjonsrett.
4. Til montering av dette produktet kreves det 2 personer.
5. Skulle De få problemer med monteringen eller med innsettelsen av glass, så ta kontakt med Deres forhandler – **BRUK IKKE MAKT!**

**PLASSERING** : Velg et solrikt sted, hvor det er mest mulig le.

**VIKTIG** : Før du begynner og montere ditt drivhus, kontroller etter innholdsfortegnelsen, at alle deler er med. Ta ut posene fra emballasjen, for og kontrollere innholdet. Det er viktig å ikke blande delene.

Hvis det mangler noen deler, kontakt Deres forhandler.

  = Er ikke inkludert i kartongen!

**Alle tegninger av drivhuset er sett innenfra, unntatt de tegningene, hvor det er bølget ramme utenom. Disse er sett utenfra.**

**VEDLIKEHOLD** : Drivhuset bør regelmessig rengjøres med et mildt rengjøringsmiddel.

Glasset kan rengjøres med et hvilke som helst rengjøringsmiddel, det skader ikke aluminiumsprofilen eller glassklipsene.

**0. FUNDAMENT** : **Viktig!** Sørg for at sokkelen er i vinkel og vannrett.

**FERDIGSTILLELSE** : Legg sikkerhetsforskriftene inne i drivhuset på et synlig sted.

Drivhuset kan tettes i hjørner ved hjelp av silikon (følger ikke med).  

Vitavia tilbyr et stort tilbehørsprogram som gjør at du kan få optimalt utbytte av drivhuset. Kontakt deres forhandler for ytterligere opplysninger.

**SIKKERTHETSANVISNING** : Ikke klatre opp på takflatene. Det er fare for å falle.

I tifelle storm. Lukk alle åpne vinduer og dører.

I tifelle kraftig snøfall, fjern snø fra taket.

**ANMERKING** : Vi anbefaler, at De sørger for, at Deres husforsikring også dekker drivhus. Overhold alle byggvedtekter.

Typebetegnelsen må du bruke ved bestilling av evt. Reservedeler, så oppbevar monteringsanvisningen til senere bruk.



**Kvelningsfare -  
Inneholder små deler**



## Turvallisuusvaroitukset / Kokoonpano-ohjeet

1. **LUE NÄMÄ OHJEET HUOLELLISESTI JA KOKONAAN ENNEN KASVIHUONEEN ASENNUSTA.**
2. Terävät reunat ja kulmat voivat aiheuttaa vammoja. Käytä aina suojalaseja, käsineitä, kenkiä ja päähinettä käsiteltäessä alumiiniprofileja, lasi- ja olykarbonaattilevyjä. Lasinsirpaleet ovat turvallisuusriski – siivoa ne aina heti pois ja hävitä huolellisesti.
3. Ostamasi tuote on tarkoitettu ainoastaan kasvien kasvattamiseen ja sitä tulee käyttää vain tähän tarkoitukseen. Jos tuotetta käytetään tarkoituksen vastaisesti tai väärin, valmistaja ei ota vastuuta mahdollisista vahingoista.
4. On suositeltavaa, että kaksi henkilöä on kokoamassa tätä kasvihuonetta.
5. Jos kohtaat vaikeuksia tämän kasvihuoneen rakentamisessa tai lasi- tai polykarbonaattilevyjen kiinnityksessä, ota yhteyttä jälleenmyyjään – **älä käytä voimaa!**
6. Kasvihuone on aina ankkuroitava.

**SIJOITUSPAIKAN VALINTA** : Valitse aurinkoinen tuulelta suojainen paikka. Suositus: sijoita harja itä-länsi suuntaisesti.

**ASENNUKSESTA: TÄRKEÄÄ** : Ennen kasvihuoneen kokoamista, tarkasta osaluettelon avulla, että kaikki osat löytyvät.

Ota jokainen nippu laatikosta osien tunnistamiseksi.

On tärkeää, että avatut niput eivät sekoitu keskenään.

Jos jotain puuttuu, ota yhteys kauppaan.



  = Ei sisälly toimitukseen!

**Huom: Kaikki kuvat on kuvattu kasvihuoneen sisältä päin, paitsi aaltoileva kehys olevat ovat ulkoapäin.**

**HUOLTO** : Kasvihuone tulee pestä ajoittain miedolla pesuaineella. Tarkasta, että käyttämäsi pesuaine sopii alumiinille ja metallisille lasikiinnikkeille. Puhdista säännöllisesti oven ala- ja yläkiskot - näin ovikiskoihin ei muodostu pinttynyttä likaa.

**0. POHJA** : Tärkeää! Pohjan tulee olla suorakulmainen, varmista ristimitalla, ja vaaterissa.

**VIIMEISTELY** : Sijoita varoituslappu kasvihuoneen sisälle.

Halutessasi voit tiivistää kasvihuoneen reunat silikonilla. Silikoni ei sisälly toimitukseen.  

Erlaisia kasvihuonevarusteita on saatavilla myyjältäsi - ota harrastuksestasi kaikki hyöty irti.

**TURVALLISUUS HUOMAUTUS** : Älä kiipeä kattopinnoille. Siellä on putoamisvaara.

Kovan tuulen ajaksi tulee ovi ja kaikki tuuletusluukut sulkea.

Poista kertynyt lumi katolta.

**HUOM** : Suosittelemme ottamaan vakuutuksen kasvihuoneellesi. Noudata kaikkia oman kuntasi rakennuksiin liittyviä säännöksiä.

Kiinnitä kasvihuoneesi tuotteen etiketti osittain 1359 asennuksen jälkeen. Tämä tieto on tärkeä, jos tarvitset myöhemmin varaosia. Säilytä nämä asennusohjeet myöhempää käyttöä varten.

Kehitämme tuotteitamme jatkuvasti ja varaamme oikeuden muuttaa tuotetietoja ilman etukäteisvaroitusta.



**Tukehtumisvaara -  
Sisältää pieniä osia**

IT

**Disposizioni di sicurezza / Descrizione della struttura****1. LEGGERE ATTENTAMENTE E COMPLETAMENTE LE ISTRUZIONI DI MONTAGGIO PRIMA DI INIZIARE I LAVORI!**



- Durante il maneggio di vetro, pannelli di policarbonato o componenti di serre si raccomanda di indossare sempre occhiali di protezione, guanti e calzature di sicurezza nonché un elmetto protettivo, poiché gli spigoli taglienti possono causare delle lesioni. I vetri rotti costituiscono un elevato rischio per la sicurezza. Eliminare i vetri rotti con la massima prudenza.
- Il prodotto acquistato è ideato per la coltivazione di piante e deve essere utilizzato esclusivamente per questo scopo. Per qualsiasi altro utilizzo si declina ogni responsabilità.
- Per il montaggio di questo prodotto sono richieste due persone.
- Qualora dovessero verificarsi delle complicazioni durante l'operazione di montaggio della serra o all'inserimento della vetratura, vogliate contattare il vostro commerciante di fiducia – **Non usare in nessun caso la forza!**
- La serra deve essere sempre ancorata al suolo.

**SCelta DEL LUOGO** : Scegliere possibilmente un posto al sole, ma al contempo protetto dal vento.

**IMPORTANTE** : Prima di iniziare l'operazione di montaggio della serra, accertarsi che siano presenti tutti i componenti elencati. Prelevare i componenti dall'imballaggio, per poterli identificare meglio.

È particolarmente importante non mischiare tra di loro i componenti aperti.

Qualora dovesse mancare qualcosa, vogliate contattare immediatamente il vostro fornitore.

  = Non è incluso nel volume di consegna!

Tutti i disegni sono illustrati dalla parte interna della serra, salvo le illustrazioni, che sono rappresentate in una cornice ondulata. Queste descrivono la veduta esterna.



**Stringere i dadi ad una coppia di max. (1002) 3 Nm / (3002) 8 Nm.**

**MANUTENZIONE** : La serra dovrebbe essere periodicamente pulita con della liscivia detergente neutra. Il vetro può essere pulito con un detergente, che non aggredisca però i componenti di materiale sintetico, i telai d'alluminio né le graffe delle molle per i vetri. Pulire periodicamente la guida di scorrimento della porta.

**0. FONDAMENTA** : **Importante!** Il fondamento deve essere assolutamente ad angolo retto e livellato.

Il fondamento deve essere trattato con una mano di antiruggine.

**LE ULTIME OPERAZIONI** : Applicare dall'interno il presente adesivo di avvertimento.

È anche possibile sigillare i giunti della serra con sigillante siliconico a reticolazione neutra. Il silicone non è incluso nel volume di consegna.  

Il vostro fornitore dispone di un assortimento completo di accessori per serre. Contattatelo.

**INFORMAZIONI DI SICUREZZA** : Non salire sulle superfici del tetto. C'è il rischio di cadere.

In presenza di vento forte si raccomanda di mantenere chiuse tutte le aperture e la porta.

Eliminare tempestivamente la neve dai tetti delle serre in modo da evitare qualsiasi carico di neve pericoloso.

**OSSERVAZIONI** : Per garantire la protezione completa della serra vi consigliamo di includerla nella vostra **polizza assicurativa domestica**. Osservare eventuali prescrizioni edilizie locali vigenti.

Incollare l'adesivo di identificazione fornito sulla parte (1359) dopo il completamento del montaggio della serra. La denominazione del tipo è richiesta per specificare eventuali pezzi di ricambio da ordinare. Conservare sempre le istruzioni per il montaggio!

Tutte le misure specificate sono valori approssimativi. Con riserva di modifiche.



**Rischio di soffocamento - Contiene piccole parti**

CS

**Bezpečnostní opatření / Popis montáže****1. PŘEČTĚTE SI CELÝ TENTO NÁVOD K MONTÁŽI PŘED ZAHÁJENÍM MONTÁŽE!**

- Při manipulaci se sklem, polykarbonátovými deskami nebo díly skleníků je nutné nosit vždy ochranné brýle, rukavice, bezpečnostní obuv a ochranu hlavy, protože může kvůli ostrým hranám dojít ke zranění. Rozbité sklo je nebezpečné. Odstraňte je s potřebnou opatrností.
- Výrobek, které jste si zakoupili, je zkonstruován k pěstování rostlin a měl by se na tento účel výlučně používat. V případě použití v rozporu s určením se vylučuje jakékoliv ručení.
- K montáži tohoto výrobku jsou potřebné dvě osoby.
- V případě problémů s montáží skleníku nebo při zasklívání kontaktujte svého prodejce – **V žádném případě nepostupujte násilně!**
- Skleník musí být ukotven.



**VÝBĚR MÍSTA INSTALACE** : Vyberte co nejslunnější místo, které je ale současně chráněno před větrem.

**DŮLEŽITÉ UPOZORNĚNÍ** : Než začnete s montáží nového skleníku, zkontrolujte, zda máte k dispozici všechny díly, které jsou uvedeny v seznamu.

Vyjměte jednotlivé balíky součástí z balení tak, abyste je lépe identifikovali.

Je důležité, abyste jednotlivé otevřené balíky vzájemně nepromíchali.

Pokud něco chybí, kontaktujte dodavatele.

  = Není součástí dodávky!

**Všechny výkresy jsou provedeny z pohledu zevnitř skleníku s výjimkou náčrsků, které jsou v vlnitý rám. Tím je označen pohled zevnitř.**

**Matice utahujte momentem max. (1002) 3 Nm / (3002) 8 Nm.**



**ÚDRŽBA** : Skleník se musí čas od času důkladně omýt roztokem neutrálního čistícího prostředku. Sklo můžete vyčistit čistícím prostředkem, který není agresivní vůči plastovým součástem, hliníkovému rámu ani pružinovým svorkám k uchycení skla.

Pravidelně čistěte vodící kolejničku dveří.

**0. ZÁKLAD** : **Důležité upozornění!** Základ musí být absolutně pravoúhlý a vodorovný.

Základ musí být proveden tak, aby nedocházelo k jeho promrznání.

**DOKONČOVACÍ PRÁCE** : Nalepte zevnitř přiložené výstražné nálepky.

Pokud si přejete, můžete spáry ve skleníku utěsnit neutrálním silikonem. Silikon není součástí dodávky.  

Dodavatel nabízí bohatý sortiment příslušenství skleníků. Kontaktujte ho.

**BEZPEČNOSTNÍ UPOZORNĚNÍ** : Nelezte na střešní plochy. Hrozí nebezpečí pádu.

Při vířivci, silném větru by měly být všechny otvory a dveře zavřené.

Včas odkliďte ze střech skleníků sníh tak, aby skleníky nemohly být nadměrně zatěžovány sněhem.

**POZNÁMKY** : Na ochranu skleníku doporučujeme zahrnout jeho pojistku do vašeho **pojištění domu**. Řiďte se případně stávajícími místními stavebními předpisy.

Dodanou nálepkou o typu nalepte po provedení montáže skleníku na část (1359). Typové označení potřebujete k uvedení při objednávání, příp. potřebných náhradních dílů. Návod k montáži si uschovejte!

Všechny rozměry jsou přibližné hodnoty. Změny vyhrazeny.



**Nebezpečí udušení - Obsahuje malé části**

**1. PRZED ROZPOCZĘCIEM MONTAŻU PROSZĘ PRZECZYTAĆ CAŁKOWICIE TĘ INSTRUKCJĘ MONTAŻU!**

2. Przy obchodzeniu się ze szkłem, płytami z poliwęglanu lub częściami szklarni należy nosić zawsze okulary ochronne, rękawice ochronne, buty ochronne i ochronę na głowę, ponieważ ostre krawędzie mogą spowodować obrażenia. Pobite szło stanowi element ryzyka. Proszę usunąć je z zalecaną ostrożnością.
3. Produkt, który został nabyty przez Państwa, został skonstruowany do hodowli roślin i może być używany wyłącznie do tego celu. W przypadku innego zastosowania wyklucza się wszelką odpowiedzialność.
4. Zaleca się montowanie produktu we 2 osoby.
5. Jeżeli będą mieli Państwo problemy podczas montażu szklarni lub w trakcie zakładania oszklwienia, to proszę skontaktować się z Państwa sprzedawcą – **proszę nie używać siły!**
6. Szklarnię należy zakotwiczyć.

**WYBÓR MIEJSCA** : Proszę wybrać słoneczne miejsce, ale jednocześnie chronione przed wiatrem.

**WAŻNE** : Zanim rozpoczną Państwo montaż szklarni, należy sprawdzić, czy występują wszystkie części wymienione na liście. Proszę wyjąć poszczególne paczki z opakowania, aby było możliwa ich lepsza modyfikacja.

Należy zwrócić uwagę, aby otwarte paczki nie wymieszały się między sobą.

Jeżeli brakuje czegoś, to proszę skontaktować się z dostawcą.

 = Nie jest zawarty w zakresie dostawy!

**Wszystkie rysunki przedstawione są od strony wewnętrznej domku, z wyjątkiem rysunków, które przedstawione są w falista ramka. Pokazują one widok z zewnątrz.**

**Nakrętki należy dokręcić przy użyciu maks. (1002) 3 Nm / (3002) 8 Nm.**

**KONSERWACJA** : Szklarnia powinna być od czasu do czasu gruntownie czyszczona za pomocą neutralnego ługu środka piorącego. Szkło może być myte środkiem czyszczącym, który nie jest agresywny w stosunku do tworzyw sztucznych, ram aluminiowych, a także klamer sprężynowych mocujących szkło. Należy regularnie czyścić szynę jezdnią drzwi.

**0. FUNDAMENT** : **Ważne!** Fundament musi być absolutnie prostokątny i płaski.

Fundament musi być wykonany w wersji odpornej na mróz.

**OSTATNIE CZYNNOŚCI** : Dołączoną naklejkę ostrzegawczą należy nakleić od wewnątrz.

Jeżeli życzą sobie tego państwo, to za pomocą silikonu można uszczelnić szklarnię na występujących już spoinach. Sylikon nie jest zawarty w zakresie dostawy. 

Państwa dostawca posiada bogaty asortyment wyposażenia szklarni. Proszę się z nim skontaktować.

**WSKAZÓWKI BEZPIECZEŃSTWA** : Nie wchodzić na powierzchnie dachowe. Istnieje niebezpieczeństwo upadku. W przypadku mocnego wiatru, wszystkie otwory i drzwi powinny być zamknięte. Dachy szklarni należy regularnie odśnieżać tak, aby nie powstały niebezpieczne obciążenia śnieżne. Należy ogrzewać budynek zimą.

**UWAGI** : W celu uzyskania pełnego zabezpieczenia szkieletu szklarni zalecamy, aby włączyć jej ubezpieczenie do ubezpieczenia domu. Proszę przestrzegać ewentualnie istniejących miejscowych przepisów budowlanych dotyczących szklarni ogrodowych.

Dostarczoną naklejkę typu należy po pomyślnym montażu szkieletu szklarni nakleić na szkielet szklarni (1359). Oznaczenie typu potrzebują Państwo do podania danych przy zamówieniu ewentualnie potrzebnych części zamiennych. Proszę przechować tę instrukcję montażu do przyszłego użytku!

Nasza polityka opiera się na nieprzerwanym doskonaleniu w związku z czym zastrzegamy sobie prawo do wprowadzania zmian w opisie bez uprzedniego powiadomienia.



**Ryzyko zadławienia -  
Zawiera małe części**

**1. PROSIMO, DA TA NAVODILA ZA MONTAŽO PRED ZAČETKOM POSTAVITVE V CELOTI PREBERETE!**

2. Pri rokovanju s steklom, polikarbonatnimi ploščami ali deli rastlinjaka morate vedno nositi zaščitna očala, rokavice, zaščitne rokavice in zaščito za glavo, ker se lahko na ostrih robovih poškodujete. Zlomljeno steklo predstavlja varnostno tveganje. Odstranite ga z zahtevano previdnostjo.
3. Izdelek, ki ste ga kupili, je zasnovan za gojenje rastlin in ga smete uporabljati izključno za ta namen. V primeru drugačne uporabe je vsakršna odgovornost izključena.
4. Za montažo tega izdelka sta potrebni dve osebi.
5. Če imate pri montaži rastlinjaka ali vstavljanju zasteklitve težave, stopite v stik s svojim trgovcem – **ne ravnajte na silo!**
6. Rastlinjak mora biti zasidran.

**IZBIRA LEGE** : Poiščite najbolj sončno lego, ki pa je hkrati zaščiten pred vetrom.

**POMEMBNO** : Preden začnete z montažo vašega rastlinjaka, preverite, ali so na voljo vsi deli, ki so navedeni na seznamu.

Da boste to lažje ugotovili, vzemite posamezne pakete iz embalaže.

Pomembno je, da odprtih paketov ne pomešate.

Če kaj manjka, stopite v stik z dobaviteljem.

 = Ni priložen!

**Vse risbe so prikazane z notranje strani rastlinjaka, z izjemo slik, ki so prikazane v valovit okvir. Te opisujejo pogled na zunanjo stran.**

**Matice privijte z največ (1002) 3 Nm / (3002) 8 Nm.**

**VZDRŽEVANJE** : Rastlinjak občasno temeljito operite z nevtralnimi čistilom. Steklo lahko očistite s čistilnim sredstvom, ki ni agresivno do plastičnih delov, aluminijastega okvirja in vzmetnih sponk za steklo.

Redno očistite vodilo vrat.

**0. TEMELJ** : **Pomembno!** Temelj mora biti absolutno pravokoten in raven.

Temelj mora biti postavljen zaščiten pred zmrzaljo.

**ZAKLJUČNA DELA** : Priloženo nalepko z opozorilom nalepite na notranji strani.

Če želite, lahko rastlinjak na fughah zatesnite z nevtralnimi silikonom. Silikon ni vsebovan v dobavi. 

Vaš dobavitelj ima na voljo bogato izbiro opreme za vaš rastlinjak. Povprašajte pri njem.

**VARNOSTNA NAVODILA** : Ne plezajte na strešne površine. Obstaja nevarnost padca.

Ob močnem vetru zaprite vse odprtine in vrata.

S streh rastlinjakov pravočasno očistite sneg, da ne pride do nevarne obremenitve s snegom.

**OPOMBE** : Za popolno zaščito rastlinjaka vam priporočamo, da ga vključite v **zavarovanje hiše**. Upoštevajte morebitne veljavne lokalne gradbene predpise.

Po namestitvi rastlinjaka na del pritrđite priloženo etiketo tipa (1359). Oznako tipa potrebujete za navedbo pri naročilu morebitnih potrebnih nadomestnih delov. Prosimo, da navodila za montažo shranite!

Vse navedene mere so približne mere. Pridržujemo si pravico do sprememb.



**Nevarnost zadušitve -  
Vsebuje majhne dele**

**1. KÉRJÜK, A FELÉPÍTÉS MEGKEZDÉSE ELŐTT OLVASSA VÉGIG A SZERELÉSI ÚTMUTATÓT!**

- Üveggel, polikarbonát lapokkal és a melegház alkatrészeivel végzett munkához mindig védőszemüveget, kesztyűt, biztonsági cipőt és fejdődöt kell viselni, mivel az éles széles sérüléseket okozhatnak. Az összetört üveg biztonsági kockázatot jelent. Kellő óvatossággal távolítsa el.
- Az Ön által vásárolt terméket növények természetésére tervezték, és kizárólag arra használható. Ettől eltérő használat esetén semmilyen felelősséget nem vállalunk.
- A termék szereléséhez két személy szükséges.
- Amennyiben a ház összeszerelésével, vagy az üveg behelyezésével kapcsolatban nehézségei adódtak, kérjük, lépjen kapcsolatba az értékesítővel – **Ne alkalmazzon erőszakot!**
- A melegházat le kell horgonyozni.

**TELEPÍTÉSI HELY VÁLASZTÁS** : A telepítéshez napos, de szélvédett helyet válasszon.

**FONTOS** : Mielőtt elkezdene összeszerelni a melegházat, ellenőrizze, hogy a listán szereplő alkatrészek mindegyike megvane.

Vegye ki az egyes csomagokat a csomagolásból a könnyebb azonosíthatóság érdekében.

Fontos, hogy a kinyitott csomagok tartalma ne keveredjen.

Ha valami hiányzik, kérjük, vegye fel a kapcsolatot beszállítójával.

 = Nem képezi a szállítási terjedelem részét!

**A rajzok mindegyike a ház belsejéből nézve készült, kivéve azokat az ábrákat, amelyek hullámos keret vannak. Ezek a külső nézetet jelentik meg.**

**Az anyákat max. (1002) 3 Nm / (3002) 8 Nm - rel húzza meg.**

**KARBANTARTÁS** : A melegházat időről időre alaposan le kell mosni semleges mosólúggal. Az üveget olyan tisztítószerrel tisztítsa, amely sem a műanyag alkatrészeket, sem az alumínium keretet, és sem az üvegrögzítő kapcsokat nem támadja meg.

Az ajtó futósínjeit rendszeresen tisztítsa.

**0. ALAPZAT** : **Fontos!** Az alapzatnak teljes mértékben derékszögűnek és síknak kell lennie.

Az alapzatot fagymentesre kell készíteni.

**AZ UTOLSÓ MOZDULATOK** : A mellékelt figyelmeztető címkéket belülről ragassza fel.

Ha gondolja, semlegesen térhálószodó szilikonnal szigetelheti a melegházakat a meglévő fugáknál.

A szilikon nem képezi a szállítási terjedelem részét. 

Beszállítója melegház-tartozékok gazdag választékával áll az Ön rendelkezésére. Beszéljen vele.

**BIZTONSÁGI UTASÍTÁS** : Ne másszon fel a tetőfelületekre. Fennáll a lezuhanás veszélye.

Erős szél esetén az összes nyílást, valamint az ajtót zárva kell tartani.

A havat a melegházak tetejéről idejében kell letakarítani ahhoz, hogy veszélyes hőterhelés ne léphessen fel.

**MEGJEGYZÉSEK** : A melegház teljeskörű védelme érdekében javasoljuk, hogy először foglaltassa bele **házának biztosításába**. Vegye figyelembe az esetleges helyi építési előírásokat.

Az üvegház sikeres összeszerelése után rögzítse a típuscímkéket az alkatrésze (1359). A típusmegjelölést az esetlegesen szükséges cserealkatrészek megrendelésénél kell megadni. Kérjük, őrizze meg a szerelési útmutatót! Minden megadott méret közelítő érték. A változtatások jogát fenntartjuk.



Fulladást okozhat -  
Kis alkatrészeket  
tartalmaz

**1. MOLIMO VAS PROČITAJTE OVU UPUTU ZA UPORABU U CIJELOSTI PRIJE NEGO POČNETE SA SASTAVLJANJEM!**

- Prilikom rukovanja sa staklom, polikarbonskim pločama ili elementima staklenika trebaju se nositi zaštitne naočale, rukavice, sigurnosne cipele i zaštita za glavu, pošto oštri rubovi mogu prouzrokovati ozljede. Puknuto staklo je sigurnosni rizik. Pažljivo ga uklonite.
- Proizvod koji ste kupili konstruiran je za uzgoj biljaka i isključivo se treba koristiti u tu svrhu. Kod korištenja u druge svrhe isključuje se svaka vrsta jamstva.
- Za montažu ovog proizvoda potrebne su dvije osobe.
- Ukoliko prilikom montaže kuće ili prilikom umetanja stakala budete imali poteškoća, kontaktirajte Vašeg trgovca – **Nemojte primjenjivati silu!**
- Kućiste se mora ukotviti.

**IZBOR MJESTA POSTAVLJANJA** : Odaberite sunčano mjesto koje je istovremeno zaštićeno od vjetra.

**VAŽNO** : Prije nego započnete sa montažom Vašeg staklenika provjerite, da li postoje svi dijelovi navedeni u popisu. Izvadite pojedinačne svežnjeve iz ambalaže, kako biste ih mogli bolje identificirati.

Važno je, da se otvoreni svežnjevi ne pomiješaju.

Ukoliko nešto nedostaje, kontaktirajte molimo Vas Vašeg dobavljača.

 = Nije priložen!

**Svi crteži prikazani su gledano sa unutrašnje strane kuće, izuzev slike, koje su prikazane u valoviti okvir. One prikazuju pogled izvana.**

**Matice pritegnite sa max. (1002) 3 Nm / (3002) 8 Nm.**

**ODRŽAVANJE** : Staklenik se povremeno treba temeljito oprati sa neutralnom lužinom za pranje. Staklo se može očistiti sa sredstvom za pranje stakla, koje ne nagriza plastiku, aluminijske okvire ili opružne spojke za staklo. Očistite redovno vodilicu za vrata.

**0. TEMELJ** : **Važno!** Temelj mora potpuno biti pravokutan i ravan.

Temelj se mora napraviti tako da je zaštićen protiv hrđe.

**ZADNJI RUKOVATI** : Priloženu naljepnicu s upozorenjem naljepite iznutra.

Ukoliko želite, staklenik na prednjim fugama možete zabrtviti silikonom. Silikon nije priložen. 

Vaš dostavljač Vam nudi opširnu ponudu pribora za staklenike. Razgovarajte s njim:

**SIGURNOSNE UPUTE** : Nemojte se penjati na krovne površine. Postoji opasnost od pada.

Kod jakog vjetra se moraju zatvoriti svi otvori i vrata.

Sa krovova staklenika se blagovremeno treba ukloniti snijeg, tako da ne može nastati opasno opterećenje snijegom.

**PRIMJEDBE** : Za potpunu zaštitu staklenika preporučamo, da ga uključite u Vaše osiguranje kuće. Obratite pozor na možebitno postojeće lokalne građevinske propise.

Nakon pričvršćivanja staklenika, pričvrstite isporučenu oznaku vrste na dio (1359). Oznaka tipa Vam je potrebna prilikom naručivanja eventualno potrebnih zamjenskih dijelova. Sačuvajte uputu za montažu!

Svi podaci mjera sa približne vrijednosti. Izmjene ostaju pridržane.



Opasnost od gušenja -  
Sadrži male dijelove

BS

**Sigurnosne mjere zaštite / Opis sastavljanja****1. MOLIMO VAS PROČITAJTE OVU UPUTU ZA UPOTREBU U CIJELOSTI PRIJE NEGO POČNETE SA SASTAVLJANJEM!**

- Prilikom rukovanja sa staklom, polikarbonskim pločama ili elementima staklenika trebaju se nositi zaštitne naočale, rukavice, sigurnosne cipele i zaštita za glavu, pošto oštri rubovi mogu prouzrokovati ozljede. Puknuto staklo je sigurnosni rizik. Pažljivo ga uklonite.
- Proizvod koji ste kupili konstruiran je za uzgoj biljaka i isključivo se treba koristiti u tu svrhu. Kod korištenja u druge svrhe isključuje se svaka vrsta garancije.
- Za montažu ovog proizvoda potrebne su dvije osobe.
- Ukoliko prilikom montaže kuće ili prilikom umetanja stakala budete imali poteškoća, kontaktirajte Vašeg trgovca – **Nemojte primjenjivati silu!**
- Kućište se mora ukotviti.

**IZBOR MJESTA POSTAVLJANJA** : Odaberite sunčano mjesto koje je istovremeno zaštićeno od vjetra.

**VAŽNO** : Prije nego započnete sa montažom Vašeg staklenika provjerite, da li postoje svi dijelovi navedeni u popisu. Izvadite pojedinačne svežnjeve iz ambalaže, kako biste ih mogli bolje identificirati.

Važno je, da se otvoreni svežnjevi ne pomiješaju.

Ukoliko nešto nedostaje, kontaktirajte molimo Vas Vašeg dobavljača.

 = Nije priložen!

Svi crteži prikazani su gledano sa unutrašnje strane kuće, izuzev slike, koje su prikazane u valoviti okvir. One prikazuju pogled izvana.

**Maticice pritegnite sa max. (1002) 3 Nm / (3002) 8 Nm.**

**ODRŽAVANJE** : Staklenik se povremeno treba temeljito oprati sa neutralnom lužinom za pranje. Staklo se može očistiti sa sredstvom za pranje stakla, koje ne nagriza plastiku, aluminijske okvire ili opružne spojke za staklo. Očistite redovno vodilicu za vrata.

**0. TEMELJ** : **Važno!** Temelj mora potpuno biti pravokutan i ravan.

Temelj se mora napraviti tako da je zaštićen protiv hrđe.

**ZADNJE RADNJE** : Priloženu naljepnicu sa upozorenjem nalijepite iznutra.

Ukoliko želite, staklenik na prednjim fugama možete zabrtviti silikonom. Silikon nije priložen. 

Vaš dostavljač Vam nudi opširnu ponudu pribora za staklenike. Razgovarajte s njim:

**SIGURNOSNE UPUTE** : Nemojte se penjati na krovne površine. Postoji opasnost od pada.

Kod jakog vjetra se moraju zatvoriti svi otvori i vrata.

Sa krovova staklenika se blagovremeno treba ukloniti snijeg, tako da ne može nastati opasno opterećenje snijegom.

**PRIMJEDBE** : Za potpunu zaštitu staklenika preporučamo, da ga uključite u Vaše osiguranje kuće. Obratite pozor na eventualno postojeće lokalne građevinske propise.

Priloženu naljepnicu sa naznakom tipa nakon montaže staklenika nalijepite na na deo (1359). Oznaka tipa Vam je potrebna prilikom naručivanja eventualno potrebnih zamjenskih dijelova. Sačuvajte uputu za montažu!

Svi podaci mjera sa približne vrijednosti. Izmjene ostaju pridržane.



**Opasnost od gušenja -  
Sadrži male dijelove**

RO

**Măsurile de siguranță / Instrucțiunile de montaj****1. VĂ RUGĂM SĂ CITIȚI INTEGRAL ACESTE INSTRUCȚIUNI, ÎNAINTE DE A ÎNCEPE MONTAJUL !**

- Purtați întotdeauna ochelari de protecție, mănuși, încălțăminte de protecție și cască atunci când manipulați elementele din sticlă, plăcile din policarbonat sau componentele serei, deoarece muchiile ascuțite pot provoca leziuni. Sticla spartă reprezintă un risc pentru siguranță. Îndepărtați cu atenția necesară.
- Produsul achiziționat de dvs. este destinat creșterii plantelor și trebuie utilizat exclusiv în acest scop. Nu ne asumăm responsabilitatea în cazul utilizării produsului în alte scopuri.
- Pentru montarea acestui produs sunt necesare două persoane.
- În cazul în care întâmpinați dificultăți la montarea serei sau la montarea geamurilor, vă rugăm să contactați distribuitorul – **nu folosiți forța!**
- Sera trebuie ancorată.

**ALEGEREA LOCAȚIEI** : Căutați locația cea mai însorită, însă, în același timp, ferită de vânt.

**IMPORTANT** : Înainte de a începe montarea serei, verificați dacă există toate componentelor incluse în listă. Pentru o mai bună identificare a acestora, scoateți toate pachetele din ambalaj.

Este important ca pachetele desfăcute să nu se amestece între ele.

Dacă lipsesc componente, vă rugăm să contactați furnizorul.

 = Nu este inclus în setul de livrare!

**Toate schițele prezintă interiorul serei, cu excepția celor reprezentate cu un graniță ondulată. Acestea descriu vederea exterioară a serei.**

**Strângeți piulițele folosind un cuplu de maxim (1002) 3 Nm / (3002) 8 Nm.**

**ÎNȚREȚINEREA** : Din când în când sera trebuie spălată temeinic cu o soluție delicată de detergent. Sticla poate fi curățată cu un detergent care să nu atace nici componentele din material plastic, nici cadrele din aluminiu și nici clemele elastice pentru sticlă. Curățați cu regularitate șina ușii glisante.

**0. FUNDAȚIA** : **Important!** Fundația trebuie să fie neapărat dreptunghiulară și plană.

Fundația trebuie construită sub nivelul de îngheț.

**FINISAREA** : Lipiți autocolantul de avertizare în interiorul serei.

Dacă doriți, puteți etanșa rosturile serei folosind silicon. Siliconul nu este inclus în setul de livrare. 

Furnizorul dvs. a pregătit pentru dvs. o gamă completă de accesorii pentru seră. Consultați furnizorul în acest sens.

**OBSERVAȚIE PRIVIND SIGURANȚA** : Nu vă urcați pe suprafețele acoperișului. Există pericolul de cădere.

Închideți toate deschiderile și ușile, în cazul în care vântul este puternic.

Curățați la timp zăpada acumulată pe acoperișul serei, pentru a evita încărcarea periculoasă.

**OBSERVAȚII** : Pentru protejarea completă a serei dvs., vă recomandăm să o includeți în asigurarea pentru casă. Respectați eventualele norme de construcție aplicabile în locația respectivă.

După montarea seriei, lipiți eticheta de specificație inclusă în kitul de livrare la piesă (1359). Aveți nevoie de descrierea tipului serei în cazul în care doriți să comandați piesele de schimb necesare. Vă rugăm să păstrați aceste instrucțiuni de montaj!

Toate dimensiunile reprezintă valori aproximative. Sub rezerva modificărilor.



**Pericol de sufocare -  
Contine piese mici**

SK

**Bezpečnostné opatrenia / Popis konštrukcie**

1. **PRED ZAČIATKOM MONTÁŽE SI, PROSÍM, KOMPLETNE PREČÍTAJTE NÁVOD NA MONTÁŽ!**
2. Pri manipulácii so sklom, s doskami z polykarbonátu alebo s dielmi skleníka je vždy potrebné nosiť ochranné okuliare, rukavice, bezpečnostnú obuv a ochranu hlavy, pretože ostré hrany môžu viesť k poraneniám. Rozbité sklo je bezpečnostným rizikom. Odstráňte ho s potrebnou opatnosťou.
3. Vami získaný výrobok je skonštruovaný na pestovanie rastlín a mal by sa používať výhradne na tento účel. Pri inom využití je vylúčená akákoľvek záruka.
4. Na montáž tohto výrobku sú potrebné dve osoby.
5. Ak by sa pri montáži skleníka alebo pri nasadzovaní presklenia vyskytli ťažkosti, potom sa spojte s vašim predajcom – **Nepoužívajte nadmernú silu!**
6. Skleník sa musí ukotviť.



**VÝBER MIESTA :** Vyhľadajte slnečné miesto, ktoré je súčasne chránené proti vetru.

**DÔLEŽITÉ :** Skôr ako začnete s montážou skleníka, prekontrolujte, či sú k dispozícii všetky diely uvedené v zozname.

Jednotlivé balíčky vyberte z obalu, aby ste ich dokázali lepšie identifikovať.

Je dôležité, aby sa otvorené balíčky nepomiešali.

Ak niečo chýba, potom sa, prosím, spojte s Vaším dodávateľom.

  = Nepatrí do rozsahu dodávky!

**Všetky výkresy sú vyobrazené pri pohľade z vnútornej strany skleníka, s výnimkou obrázkov, ktoré sú zobrazené v vlinitý rám. Tieto opisujú vonkajší pohľad.**

**Matice utáhuje s max. (1002) 3 Nm / (3002) 8 Nm.**



**ÚDRŽBA :** Skleník by sa mal občas dôkladne poumyvať neutrálnym saponátom. Sklo je možné vyčistiť čistiacim prostriedkom, ktorý nenapáda plastové diely, hliníkový rám ani pružné zvierky pre sklo.

Pravidelne čistíte vodiacu koľajničku dverí.

**0. ZÁKLAD :** **Dôležité!** Základ musí byť absolútne pravouhlý a rovný.

Základ musí byť založený do nezamrzajúcej hĺbky.

**POSLEDNÉ KROKY :** Priložené výstražné nálepky nalepte zvnútra.

Ak chcete, môžete prítomné škáry na skleníku utesniť s neutrálnym silikónom. Silikón nepatrí do rozsahu dodávky.  

Váš dodávateľ ponúka bohatý sortiment príslušenstva pre skleníky. Oslovte ho.

**BEZPEČNOSTNÉ UPOZORNENIE :** Nevyliezajte na strešné plochy. Hrozí nebezpečenstvo pádu.

Pri silnom vetre by sa mali zatvoriť všetky otvory a dvere.

Zo striech skleníkov sa musí včas odpratávať sneh, aby nemohlo vzniknúť nebezpečné zaťaženie snehom.

**POZNÁMKY :** Na plnú ochranu skleníka odporúčame začleniť ho do vášho **poistenia domu**. Dodržiavajte prípadne existujúce miestne stavebné predpisy.

Po úspešnej inštalácii skleníkovej tyčinky na diel (1359). Označenie typu musíte uviesť pri objednávke prípadne potrebných náhradných dielov. Návod na montáž si, prosím, uschovajte!

Všetky údaje o rozmeroch sú približnými hodnotami. Zmeny vyhradené.



**Nebezpečenstvo udusenía -  
Obsahuje malé časti**

RU

**Меры безопасности / Описание сборки**

1. **ВНИМАТЕЛЬНО ПРОЧИТАЙТЕ ДАННОЕ РУКОВОДСТВО ПО МОНТАЖУ ПЕРЕД НАЧАЛОМ СБОРОЧНЫХ РАБОТ!**
2. При работе со стеклом, поликарбонатными плитами или компонентами теплицы следует всегда надевать защитные очки, перчатки, защитную обувь и защитную маску, поскольку острые края элементов конструкции могут стать причиной травм. Разбитое стекло также представляет опасность. Убирать его следует с осторожностью.
3. Приобретенное вами изделие предназначено для выращивания растений и должно использоваться исключительно с данной целью. При ненадлежащем использовании любая ответственность исключается.
4. Для монтажа данного изделия необходимы два человека.
5. Если при монтаже теплицы или при установке стекол возникли трудности, свяжитесь с продавцом – **ни в коем случае не применяйте силу!**
6. Закрепление теплицы производится при помощи анкерных болтов.

**ВЫБОР МЕСТА УСТАНОВКИ :** Следует выбирать самое солнечное и в то же время защищенное от ветра место.

**ВАЖНО :** Перед началом монтажа теплицы убедитесь, что все приведенные в спецификации детали имеются в наличии. Выньте отдельные связки из упаковки, чтобы иметь возможность их идентифицировать.

Очень важно не перепутать содержимое отдельных связок.

Если какие-то элементы отсутствуют, обратитесь к поставщику.

  = Не входит в комплект поставки!

**На всех чертежах показан вид теплицы изнутри, за исключением изображений, помещенных в волнистая рамка . На них представлен вид снаружи.**

**Гайки затягивать с максимальным усилием (1002) 3 Nm / (3002) 8 Nm.**

**УХОД :** Элементы теплицы следует тщательно мыть с нейтральным моющим средством. Стекло следует очищать при помощи чистящего средства, не агрессивного по отношению к пластиковым деталям, алюминиевой раме и скобам стекол. Направляющий рельс двери очищайте регулярно.

**0. ФУНДАМЕНТ :** **Важно!** Фундамент должен быть ровным и иметь абсолютно прямые углы.

Фундамент не должен промерзать.

**ПОСЛЕДНИЕ ШТРИХИ :** Наклейки с предупредительными надписями, входящие в комплект, наклеиваются изнутри.

При желании вы можете уплотнить имеющиеся зазоры теплицы при помощи силикона. Силикон не входит в комплект поставки.  

Ваш поставщик располагает широким ассортиментом комплектующих деталей для теплиц. Обращайтесь, пожалуйста, к нему.

**УКАЗАНИЯ ПО БЕЗОПАСНОСТИ :** Не забирайтесь на поверхности крыши. Существует опасность падения.

При сильном ветре следует закрывать дверь и окна.

Вовремя убирайте снег с крыши теплицы, чтобы не допустить чрезмерной нагрузки.

**ПРИМЕЧАНИЯ :** Для гарантии безопасности вашей теплицы советуем внести ее в страховой полис вместе с домом. Руководствуйтесь предписаниями местных органов по надзору за строительством.

После завершения установки теплицы наклейте прилагаемую наклейку с обозначением типа изделия на детали (1359).

Тип изделия вам необходимо знать при заказе комплектующих деталей. Пожалуйста, сохраняйте Руководство по монтажу!

Все данные касательно размеров даны приблизительно. Мы оставляем за собой право вносить изменения.



**Опасность удушья -  
Содержит мелкие детали**

1. **Уважно прочитайте цей посібник з монтажу перед початком монтажних робіт!**
2. При роботі зі склом, полікарбонатними плитами або компонентами теплиці слід завжди надівати захисні окуляри, рукавички, захисне взуття та захисну маску, тому що гострі краї елементів конструкції можуть стати причиною травм. Розбите скло також є небезпечним. Прибирати його слід з обережністю.
3. Придбаний вами виріб призначений для вирощування рослин і повинний використовуватися виключно з даною метою. При неналежному використанні будь-яка відповідальність виключається.
4. Для монтажу цього виробу необхідні дві особи.
5. Якщо при монтажі теплиці або при встановленні скла виникли труднощі, зв'яжіться з продавцем – **ні в якому разі не використовуйте силу!**
6. Закріплення теплиці проводиться за допомогою анкерних болтів.

**ВИБІР МІСЦЯ ДЛЯ ВСТАНОВЛЕННЯ** : Слід вибирати саме сонячне і в той же час захищене від вітру місце.

**ВАЖЛИВО** : Перед початком монтажу теплиці переконайтеся, що всі наведені в специфікації деталі є в наявності. Вийміть окремі зв'язки з упаковки, щоб мати можливість їх ідентифікувати.

Дуже важливо не переплутати вміст окремих зв'язок.

Якщо якісь елементи відсутні, зверніться до постачальника.

 = Не входить до комплекту поставки!

На всіх кресленнях зображений вид теплиці зсередини, за винятком зображень, поміщених у хвилястий каркас. На них зображений вид зовні.

**Гайки затягувати з максимальним зусиллям (1002) 3 Нм / (3002) 8 Нм.**

**ДОГЛЯД** : Елементи теплиці слід ретельно мити з нейтральним миючим засобом. Скло слід очищати за допомогою м'якого засобу, не агресивного по відношенню до пластикових деталей, алюмінієвої рами та скоб скла. Направляючу рейку дверей очищуйте регулярно.

**0. ФУНДАМЕНТ** : **Важливо!** Фундамент повинен бути рівним і мати абсолютно прямі кути.

Фундамент не повинен промерзати.

**ОСТАННІ ШТРИХИ** : Наклейки з попереджувальними написами, що входять в комплект, наклеюються зсередини.

При бажанні ви можете ущільнити наявні зазори теплиці за допомогою силікону. Силікон не входить до комплекту поставки. 

Ваш постачальник має у своєму розпорядженні широкий асортимент комплектуючих деталей для теплиць. Звертайтеся, будь ласка, до нього.

**ВКАЗІВКИ З БЕЗПЕКИ** : Не вилізайте на поверхні даху. Існує небезпека падіння.

При сильному вітрі слід закривати двері та вікна.

Вчасно прибирайте сніг з даху теплиці, щоб не допустити надмірного навантаження.

**ПРИМІТКИ** : Для гарантії безпеки вашої теплиці радимо внести її в страховий поліс разом з будинком. Керуйтеся приписами місцевих органів з нагляду за будівництвом.

Після установки теплиці закріпіть на деталі наклейку із зазначенням типу виробу, який поставляється разом із нею (1359).

Тип виробу вам необхідно знати при замовленні комплектуючих деталей. Будь ласка, зберігайте Посібник з монтажу!

Всі дані щодо розмірів надані приблизно. Ми залишаємо за собою право вносити зміни.



**Загроза задухи -  
Містить невеликі  
частини**



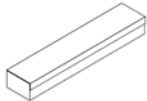
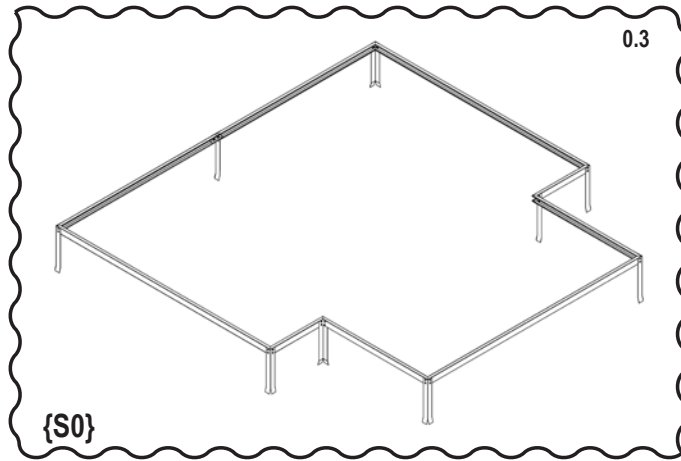
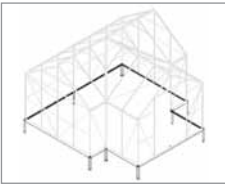

SIR,SLT,SSD, 2/6	
3001 36x	
3002 36x	
9004 4x	

SIR,SLT,SSD, 5/6 Base			
9101 6x		9121 2x	
9103 1x		9138 2x	
9106 8x		9139 2x	
9107 1x		9140 2x	
9116 3x			

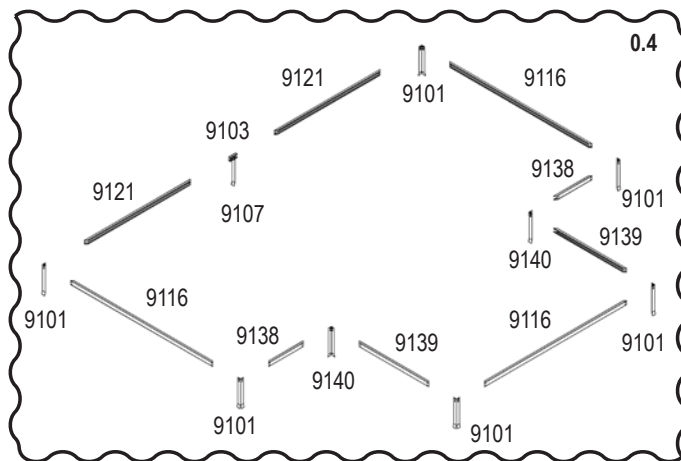

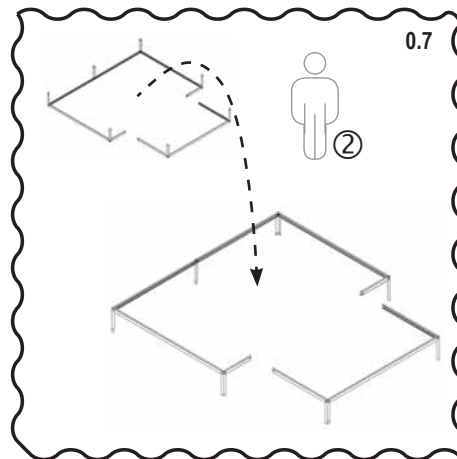
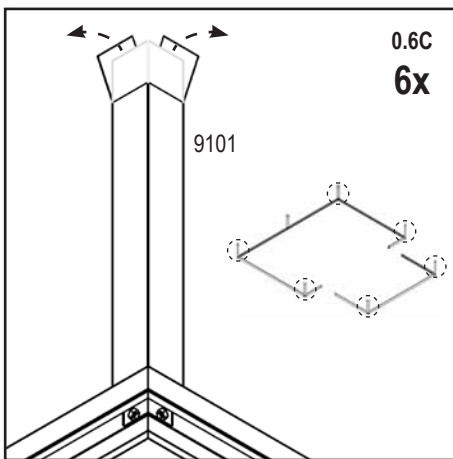
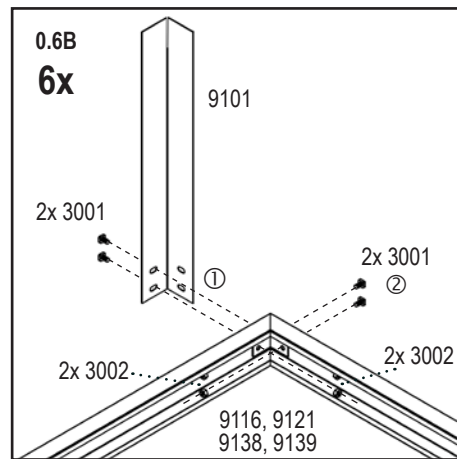
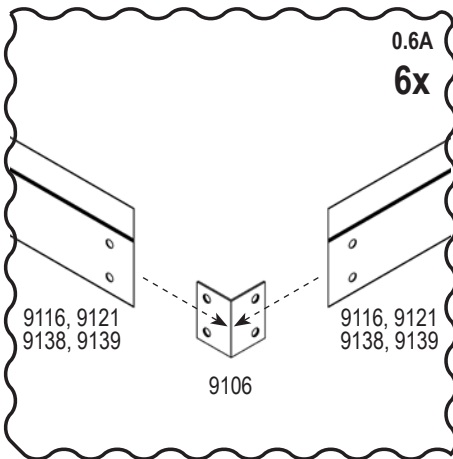
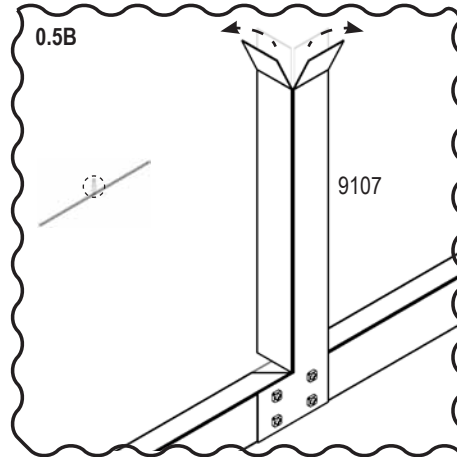
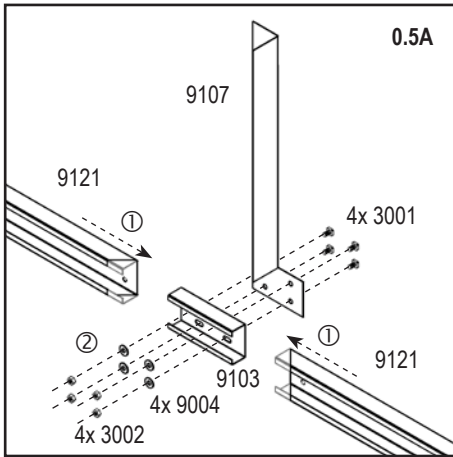
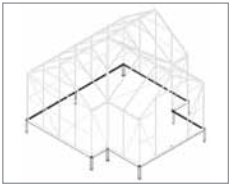

Persons required.

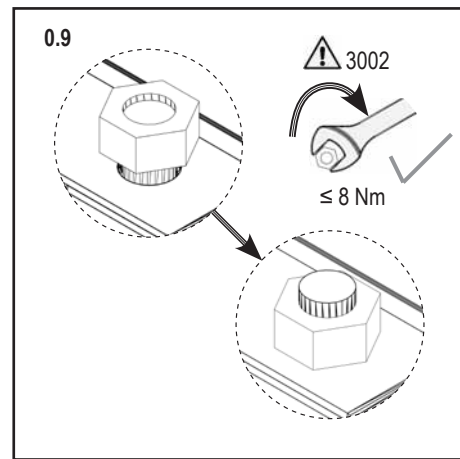
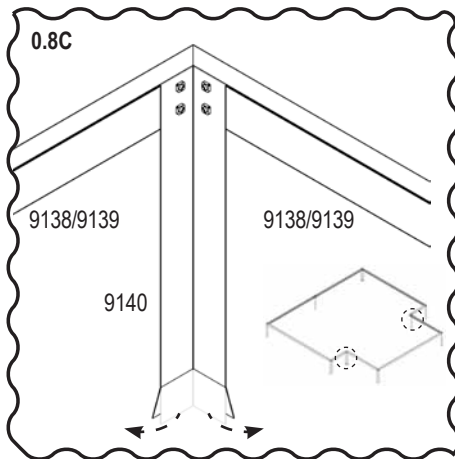
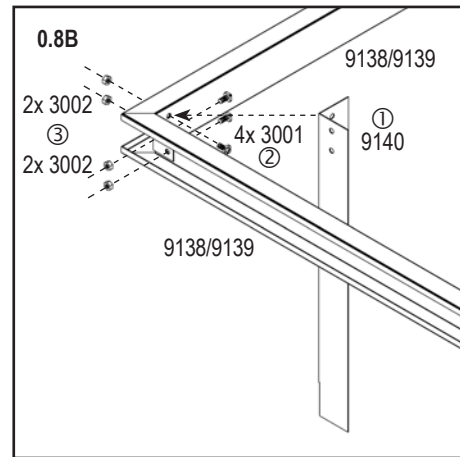
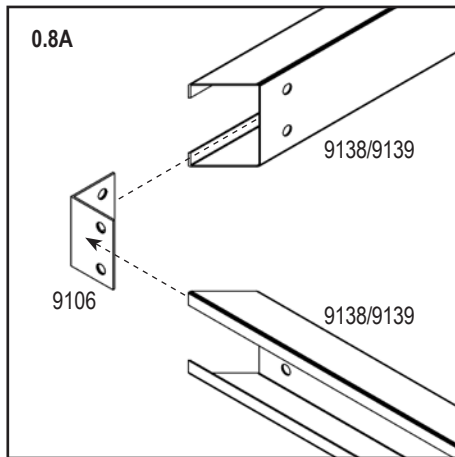

V1  
V2

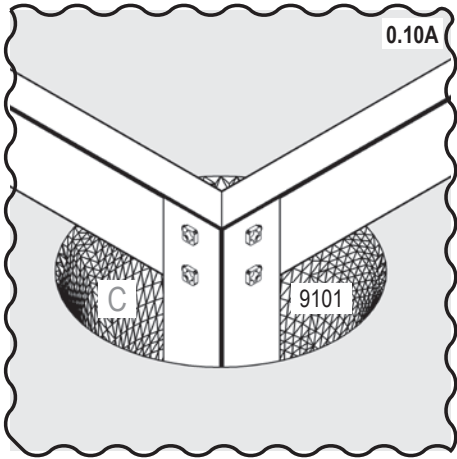

! 4.33

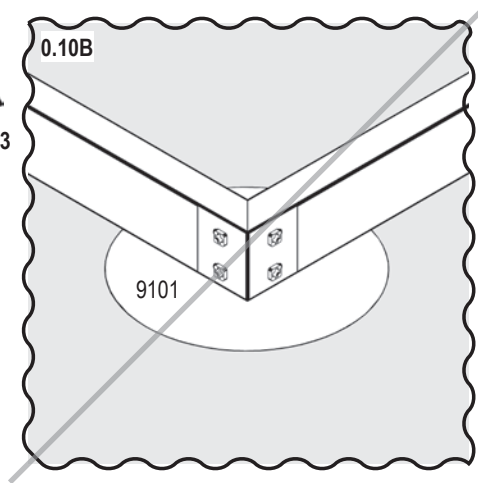

V1  
V2

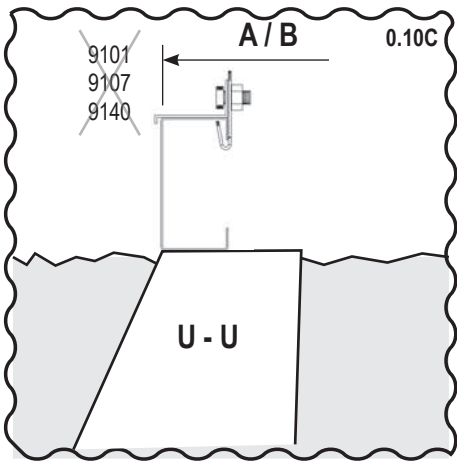

! 4.33

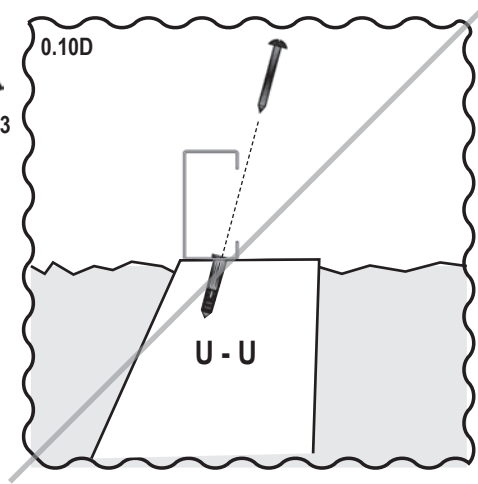

! Important!    👁 Go to    / Step for later

# 1

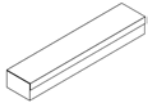
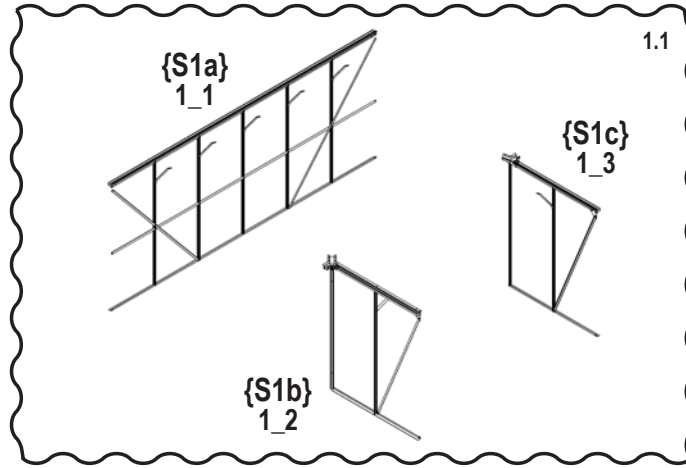
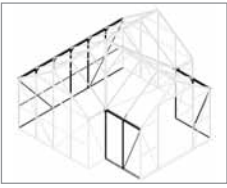

SIR,SLT,SSD, 2/6			
1092 4x		2520 2x	
2055 7x		2527 2x	
2056 7x		3001 60x	
2092 4x		3002 60x	
2500 2x			

SIR,SLT,SSD, 4/6			
2024 1x		2506 1x	
2029 1x		2507 1x	
2033 2x		2508 1x	
2049 2x		2526 1x	
2505 1x			

# 1\_1

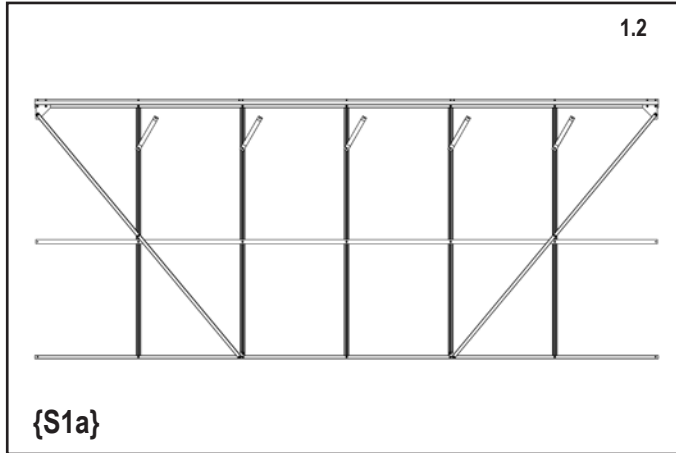
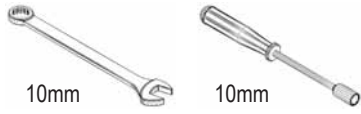
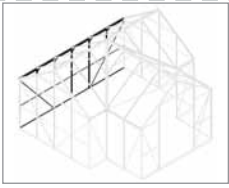

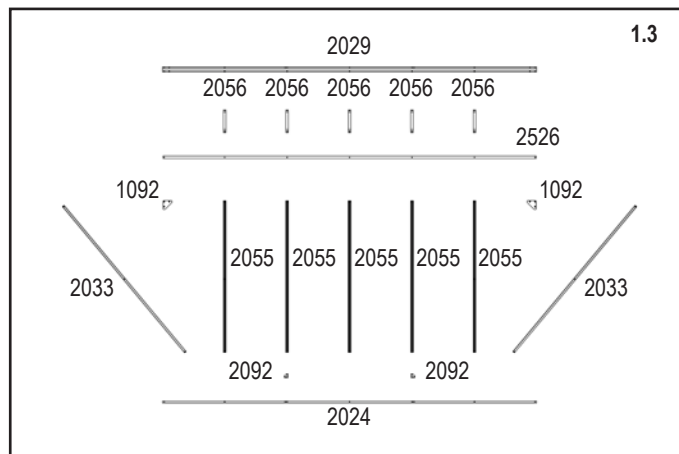

1092 2x		2055 5x		2527 2x	
2024 1x		2056 5x		3001 32x	
2029 1x		2092 2x		3002 32x	
2033 2x		2526 1x			

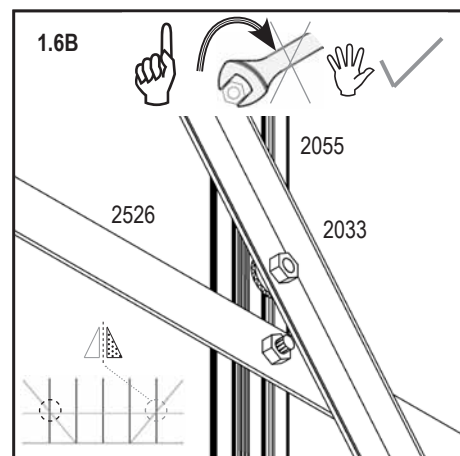
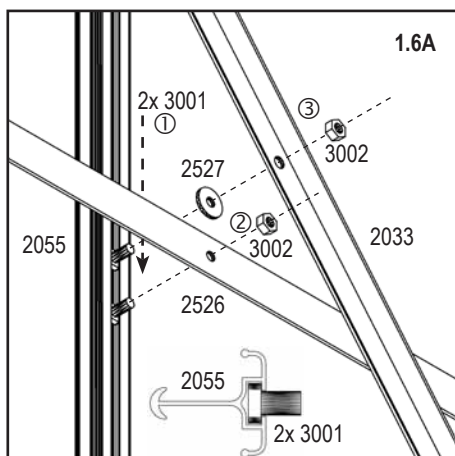
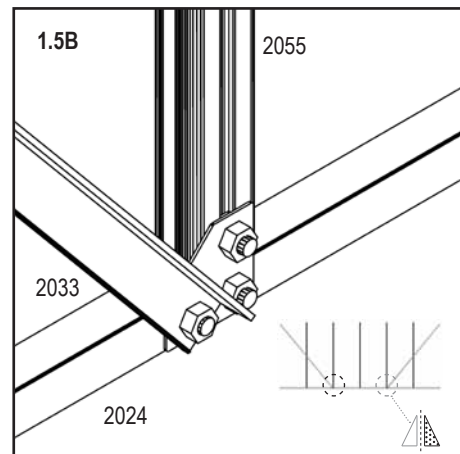
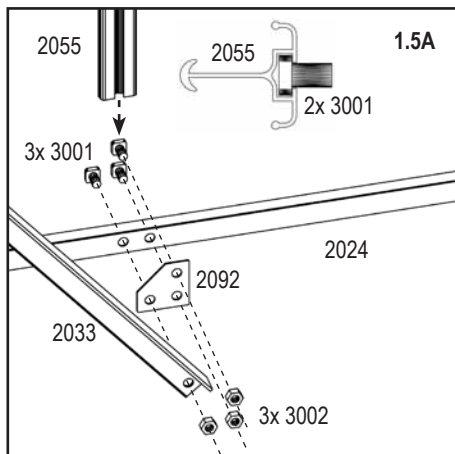
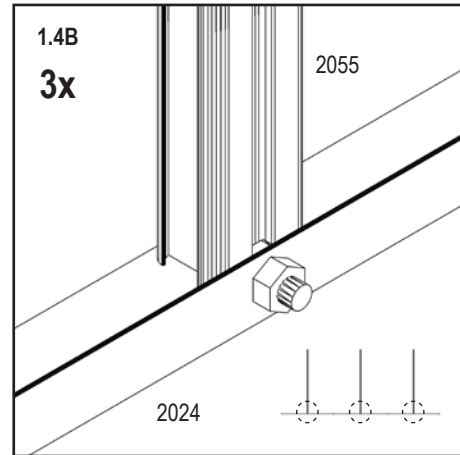
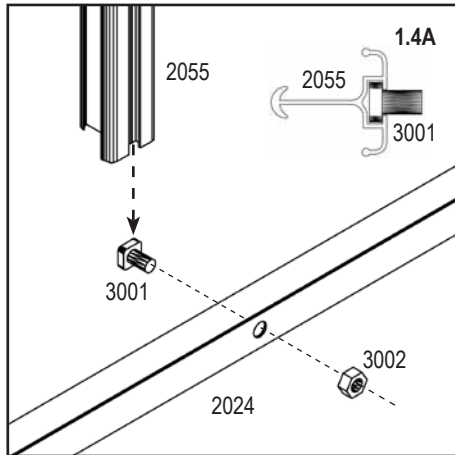

# 1\_1



 Important Tip
  Adjust by Hand
  Mirror of

# 1\_1

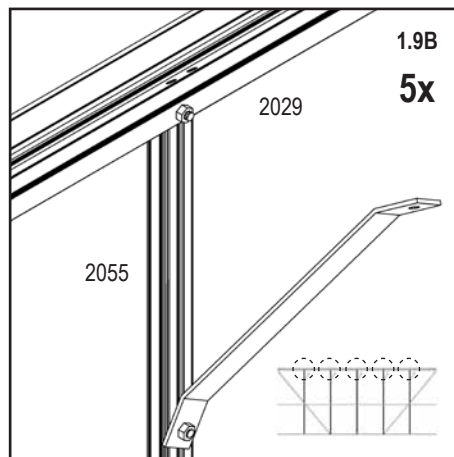
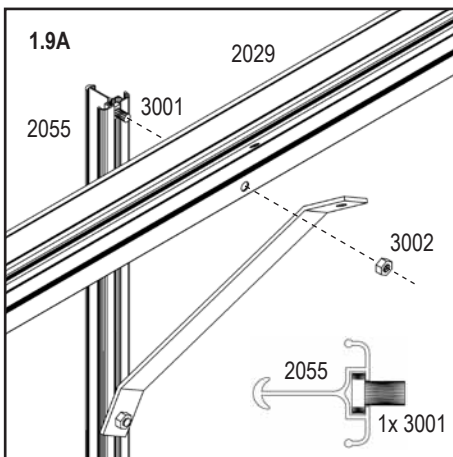
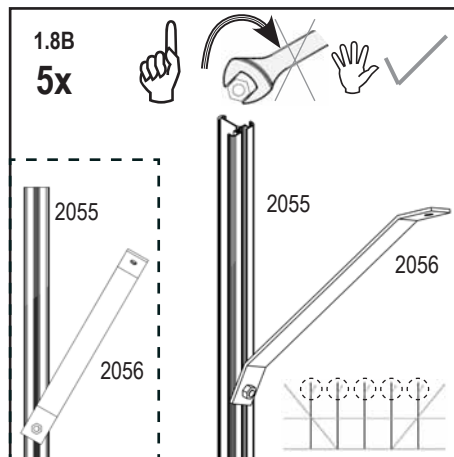
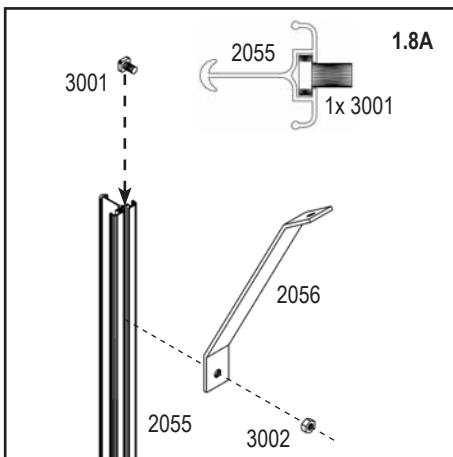
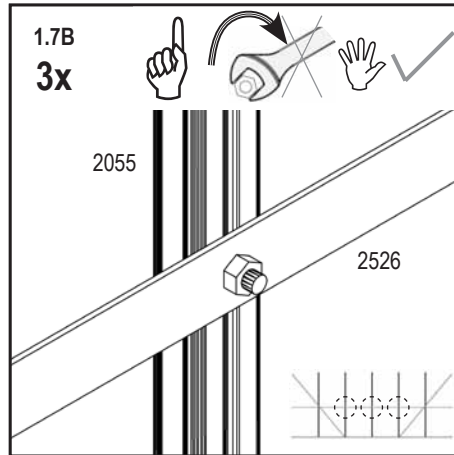
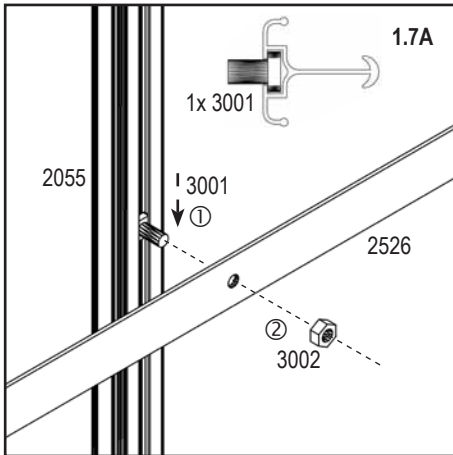

 Important! 
  Go to 
  Important Tip 
  Adjust by Hand

# 1\_1

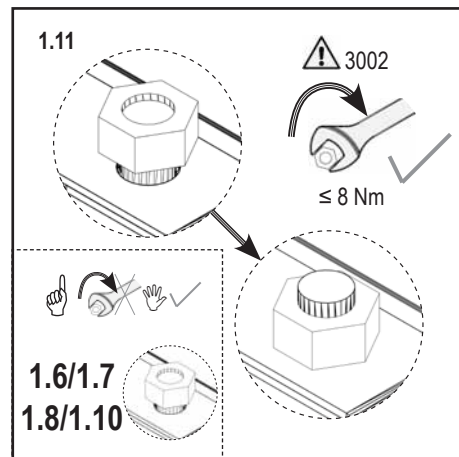
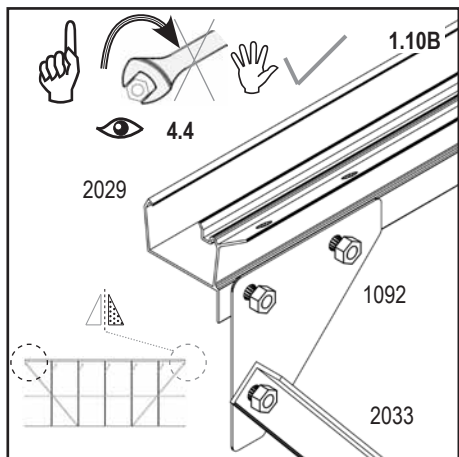
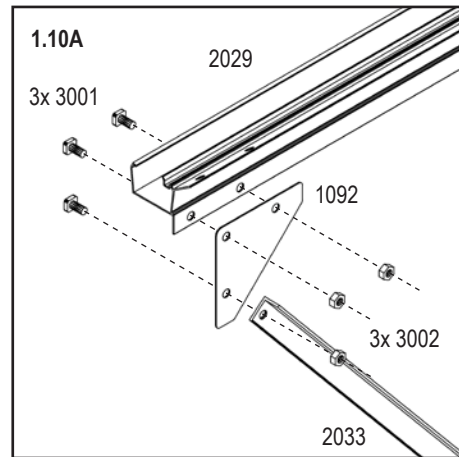
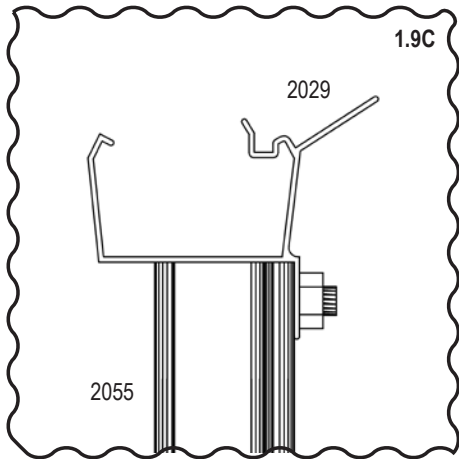

 Go to 
  Important Tip 
  Adjust by Hand 
  Mirror of

# 1\_2

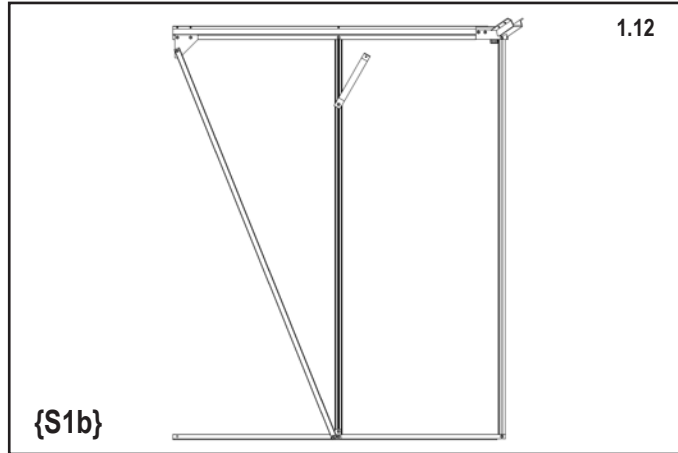
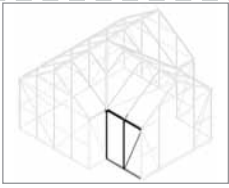

1092 1x		2092 1x		2520 1x	
2049 1x		2500 1x		3001 14x	
2055 1x		2506 1x		3002 14x	
2056 1x		2508 1x			

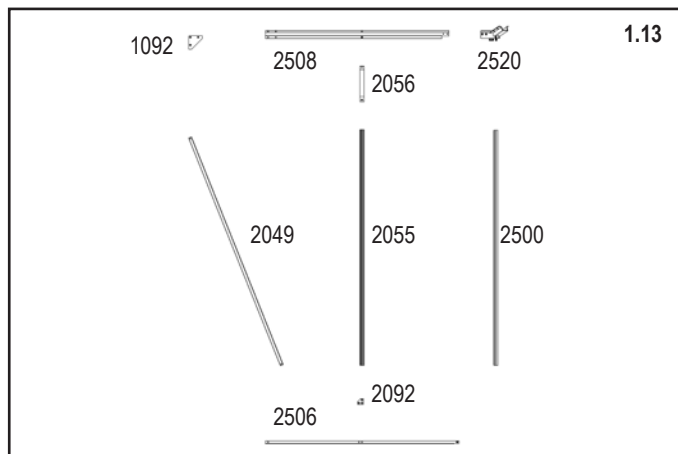

# 1\_2

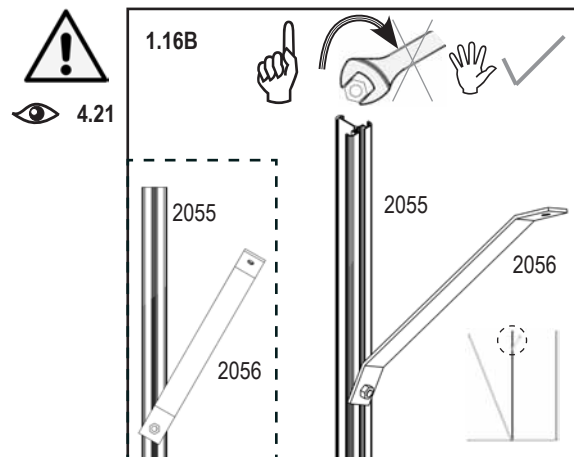
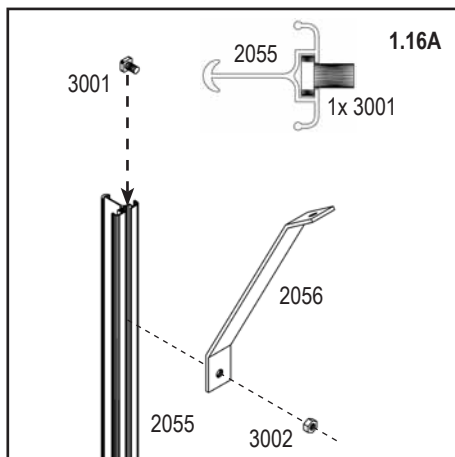
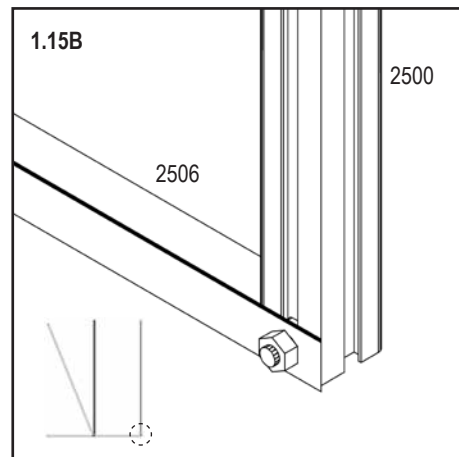
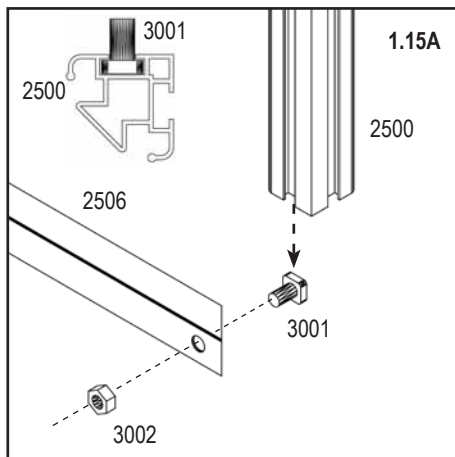
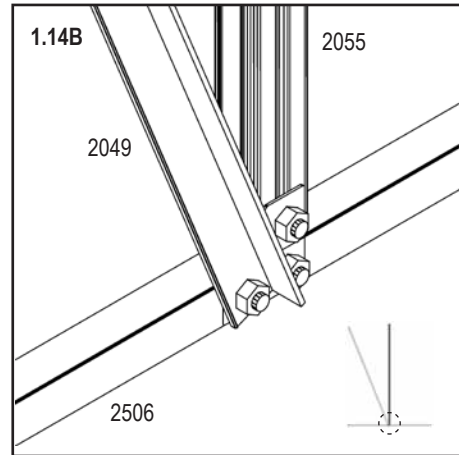
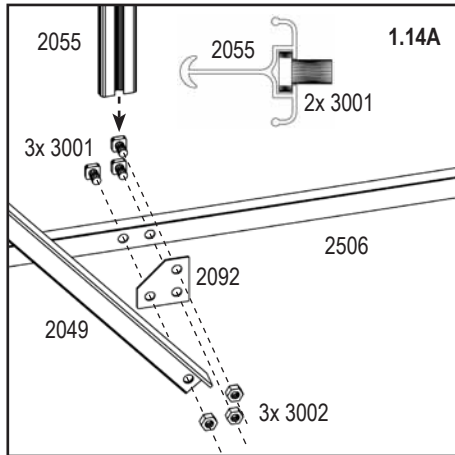

 Important! 
  Go to 
  Important Tip 
  Adjust by Hand

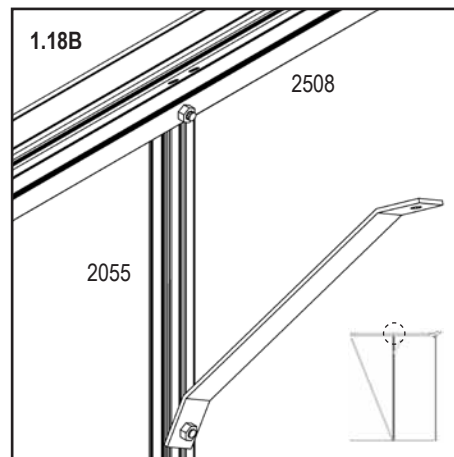
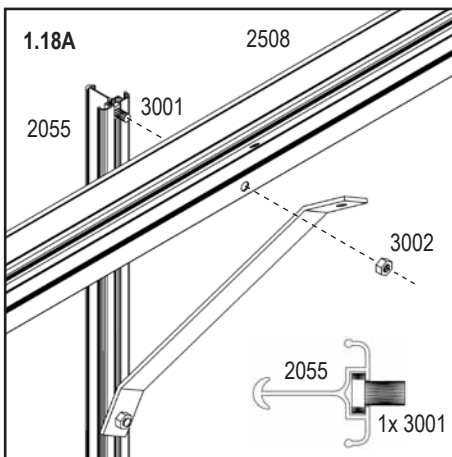
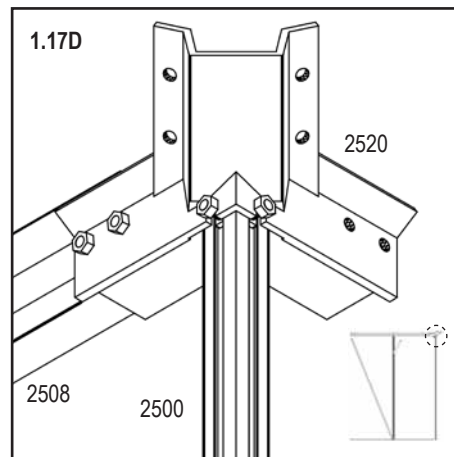
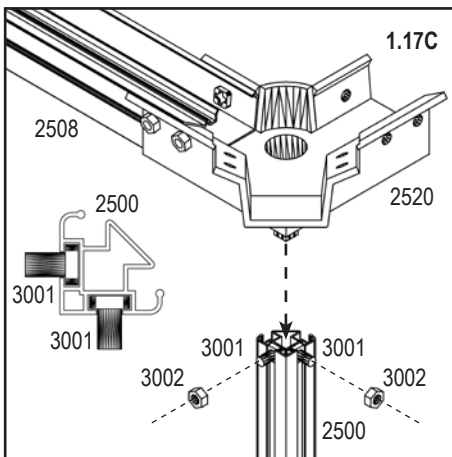
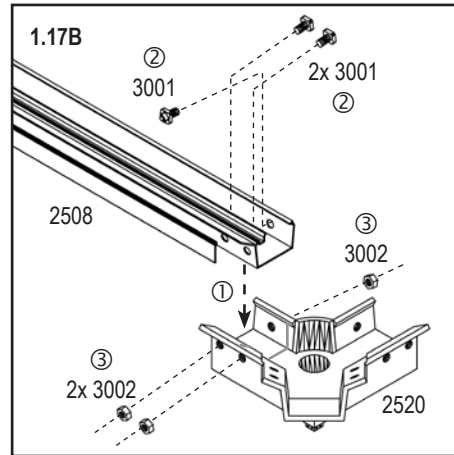
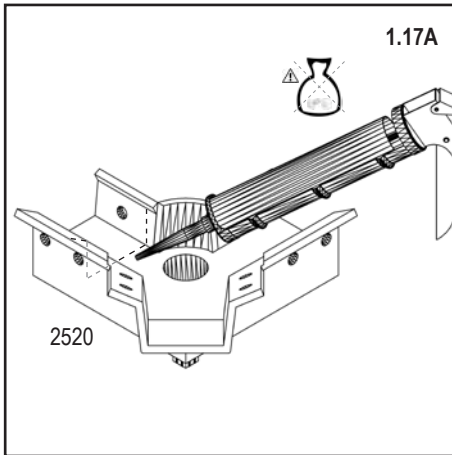

# 1\_2

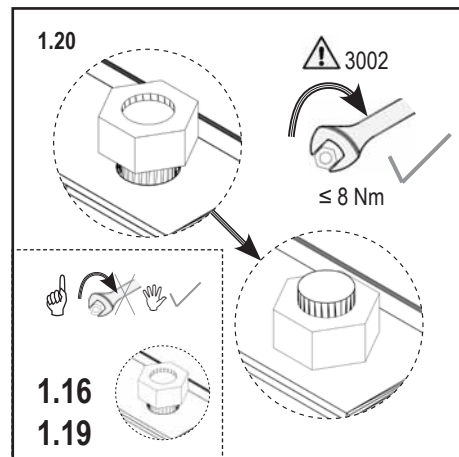
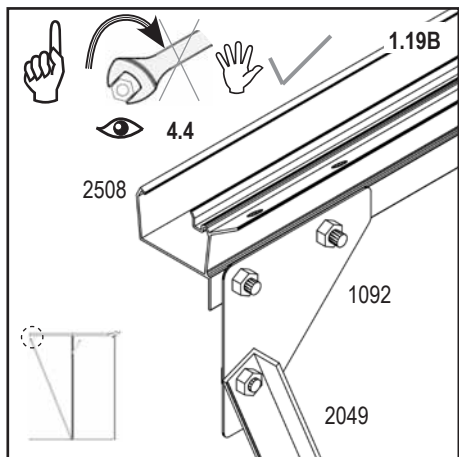
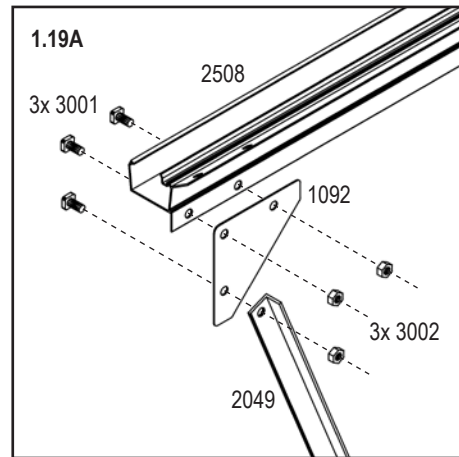
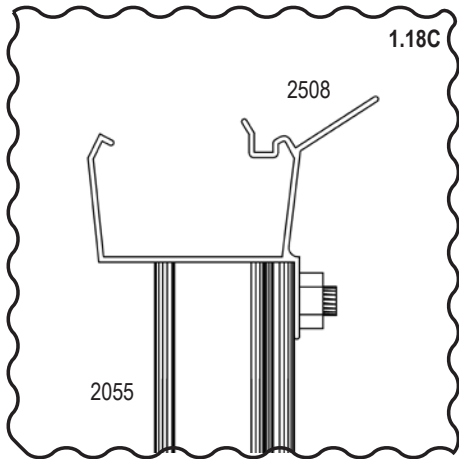

 Not included in product!

# 1\_2



 Go to  Important Tip  Adjust by Hand

# 1\_3

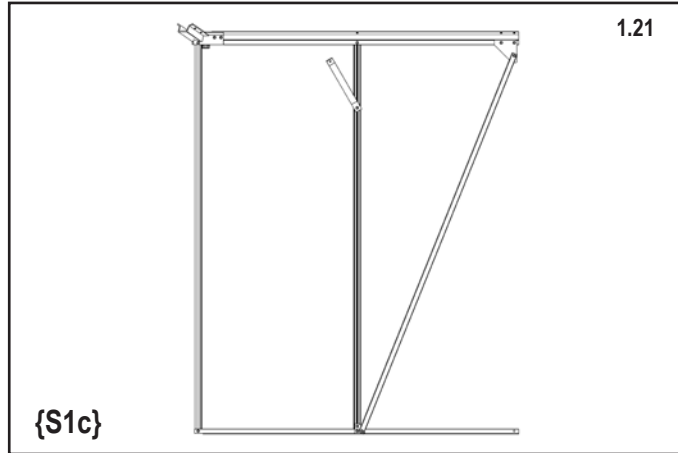
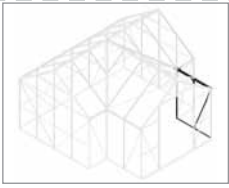

1092 1x		2092 1x		2520 1x	
2049 1x		2500 1x		3001 14x	
2055 1x		2505 1x		3002 14x	
2056 1x		2507 1x			

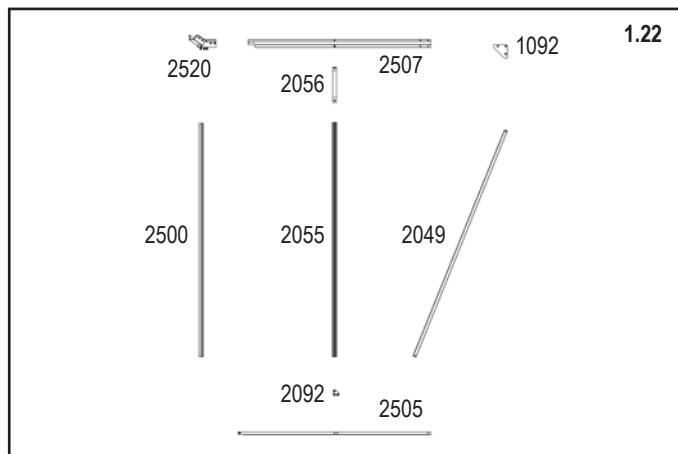

# 1\_3

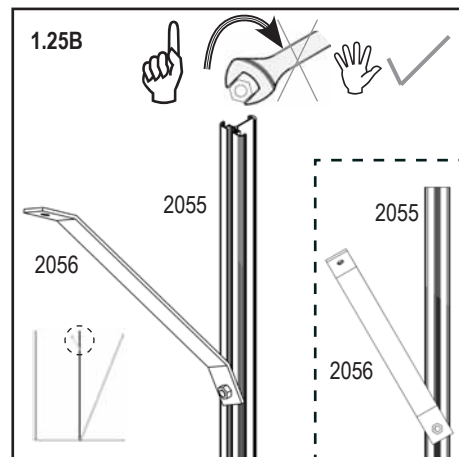
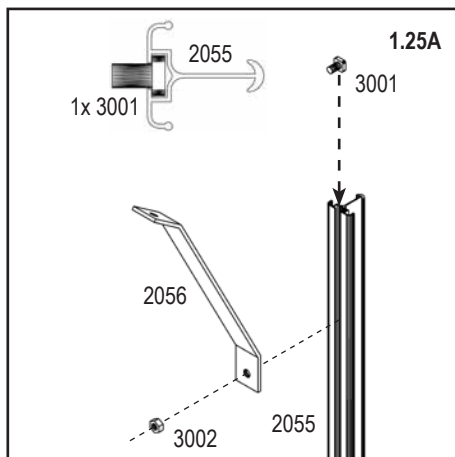
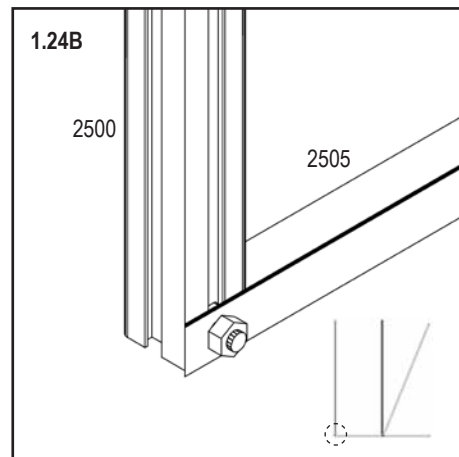
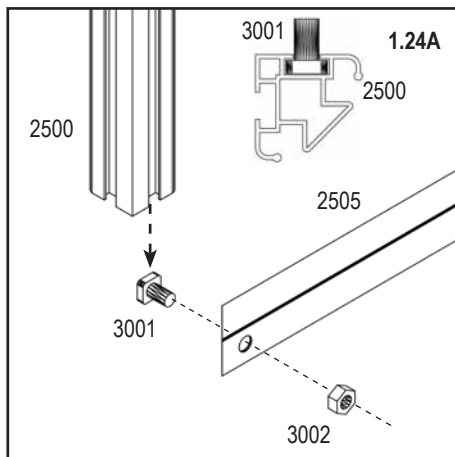
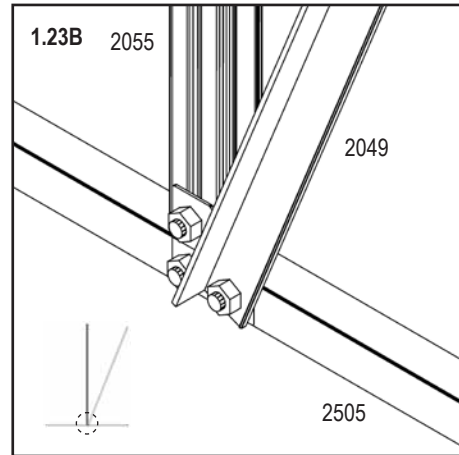
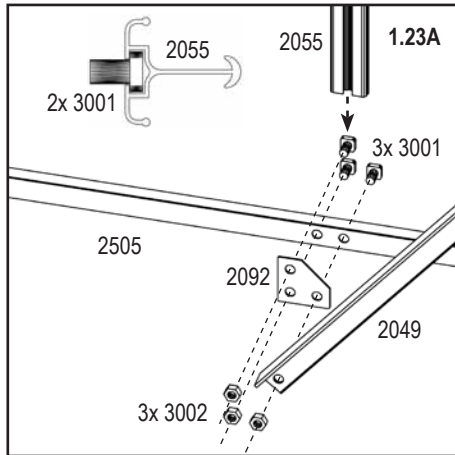

Important!



Go to



Important Tip



Adjust by Hand

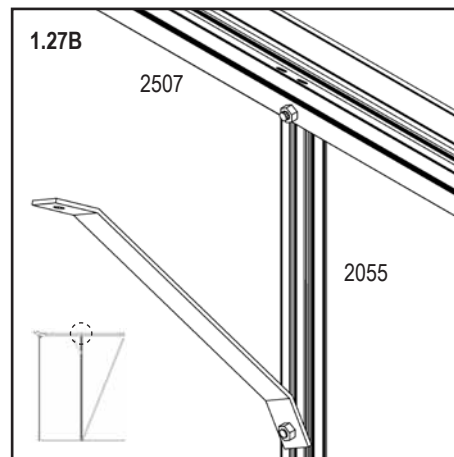
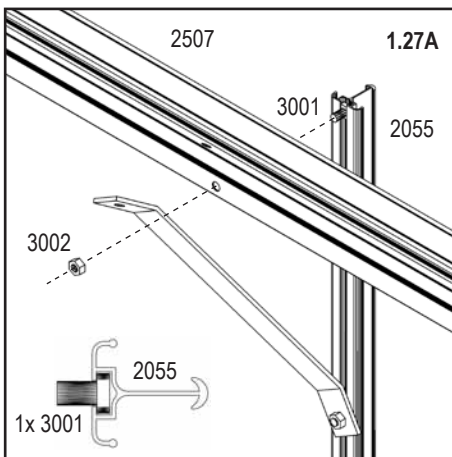
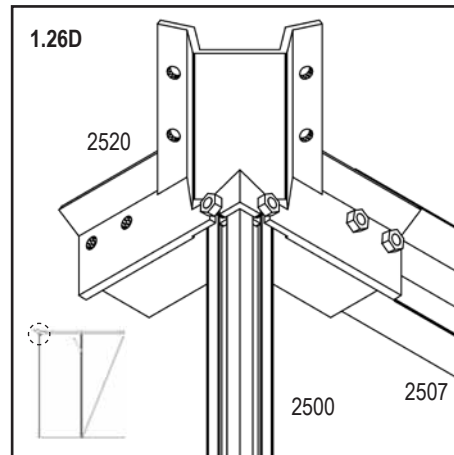
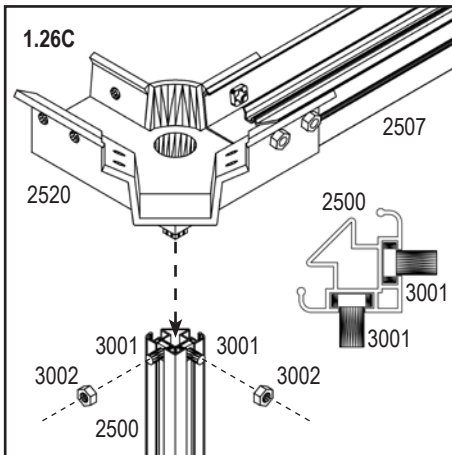
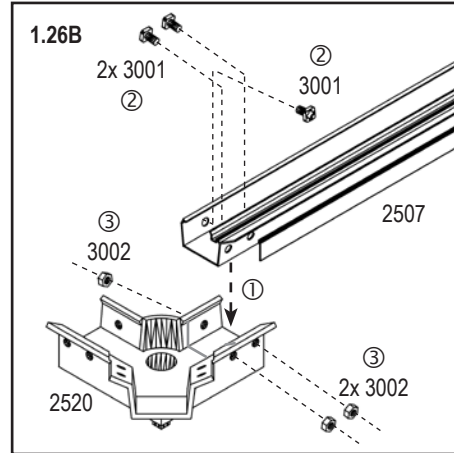
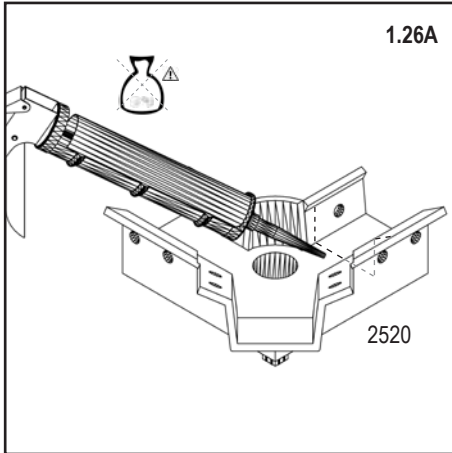

# 1\_3

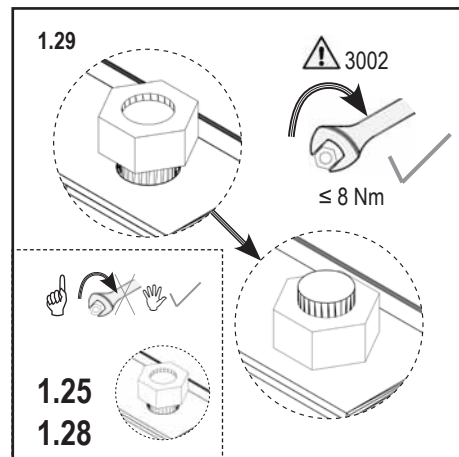
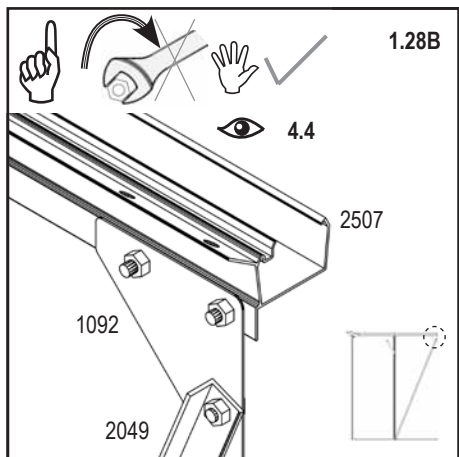
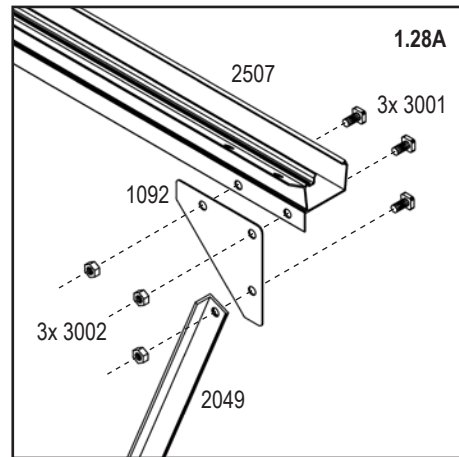
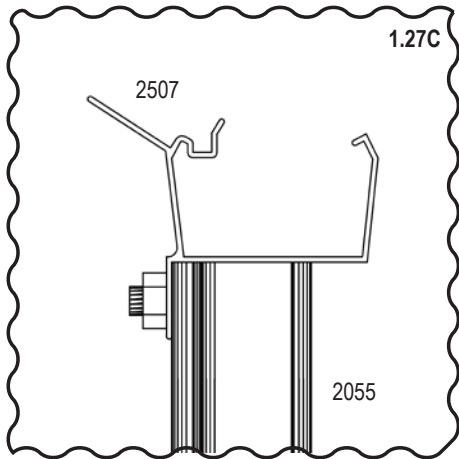

 Not included in product!

# 1\_3



 Go to  Important Tip  Adjust by Hand

# 2

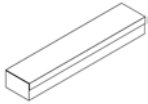
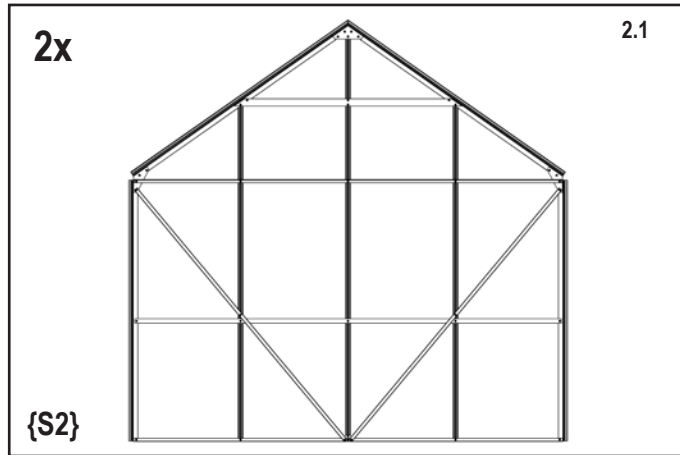
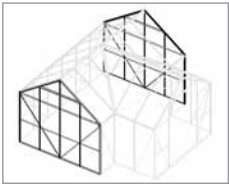

SIR,SLT,SSD, 2/6	
1043 2x 2	
2091 1x 2	
2093 1x 2	
2527 2x 2	
3001 37x 2	
3002 37x 2	

JUP,URA, 3/4_PHX,PSD, 3/5_SIR,SLT,SSD, 3/6 Back			
2022 1x 2		2041 1x 2	
2033 2x 2		2042 1x 2	
2035 1x 2		2054 1x 2	
2036 2x 2		2101 1x 2	
2039 1x 2		2100 1x 2	
2040 1x 2			

SIR,SLT,SSD, 4/6	
4279 1x 2	

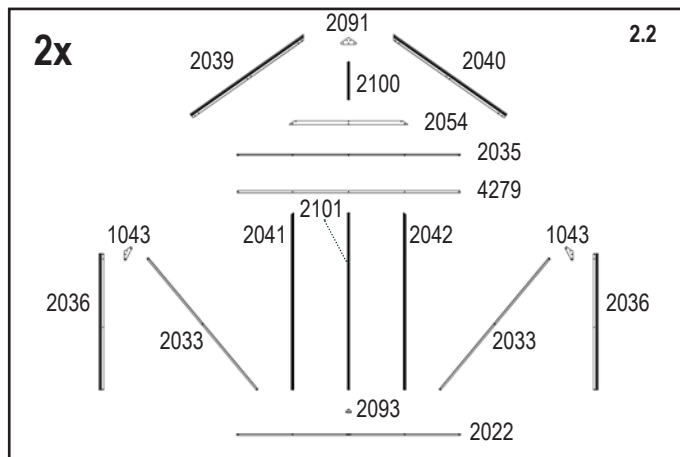

# 2

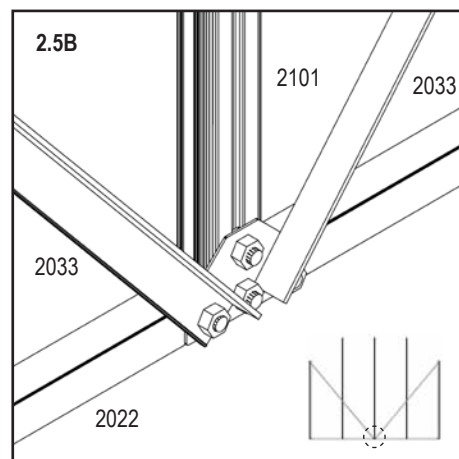
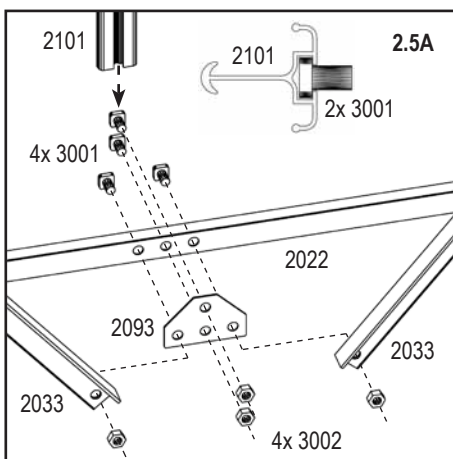
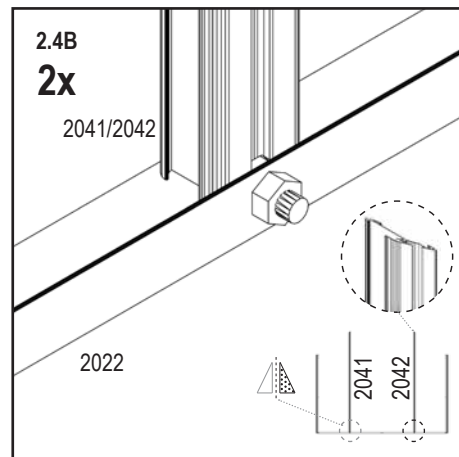
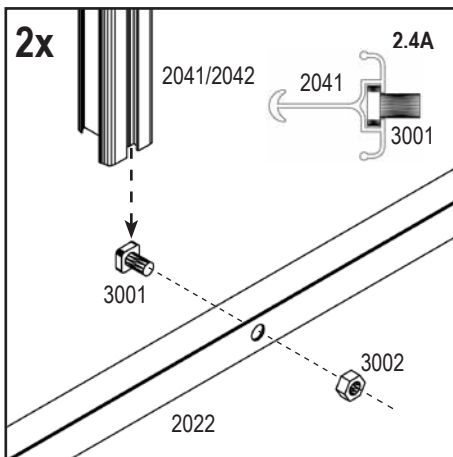
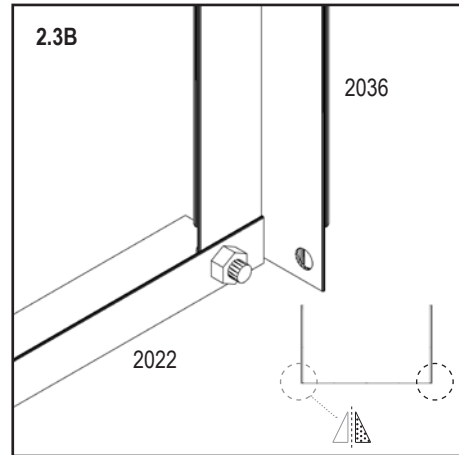
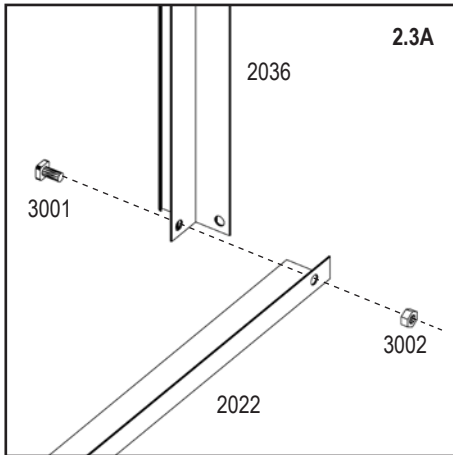
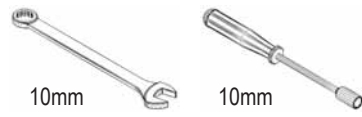
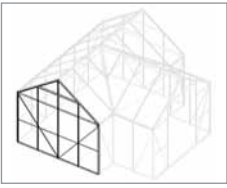

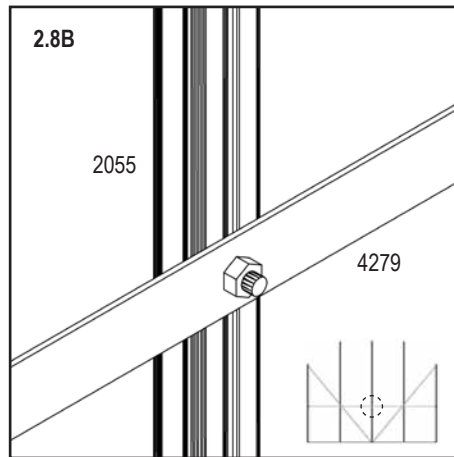
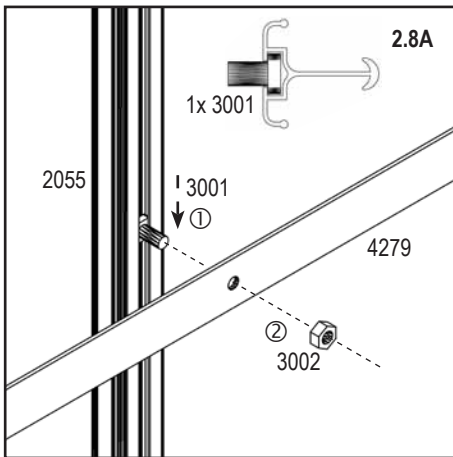
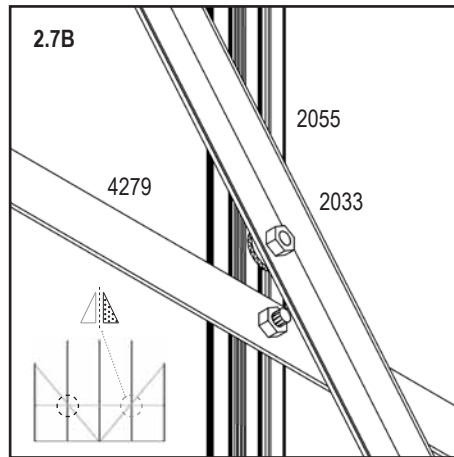
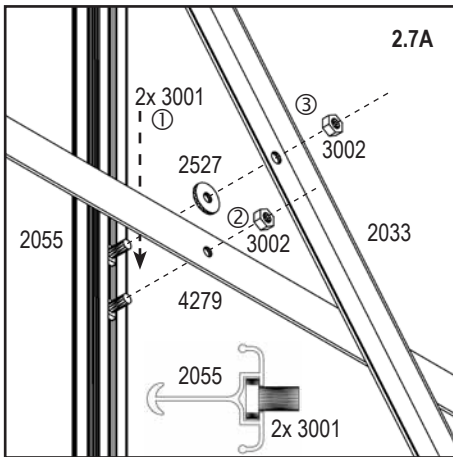
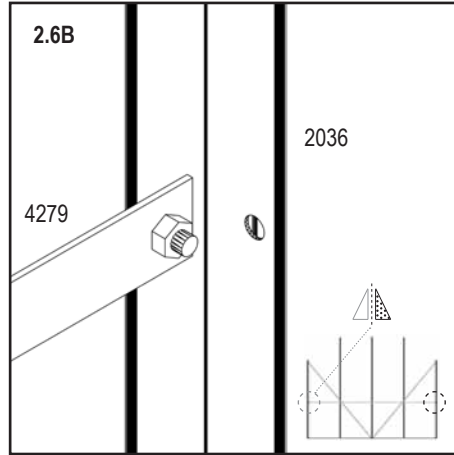
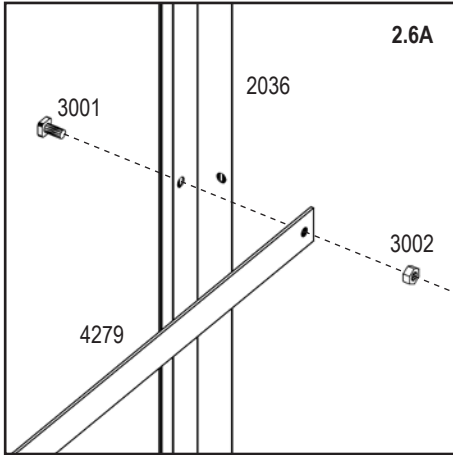

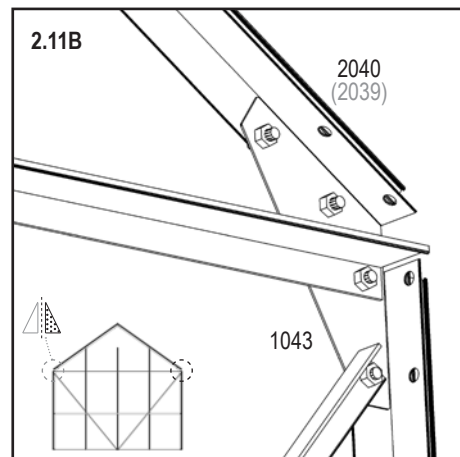
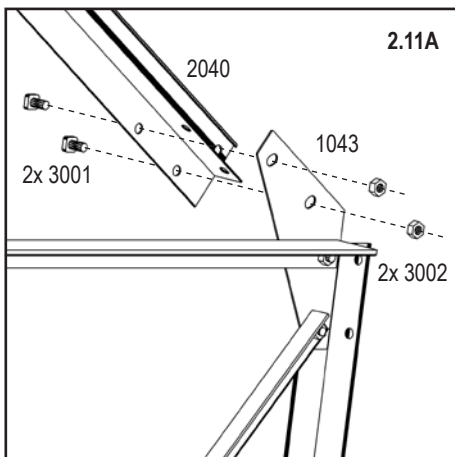
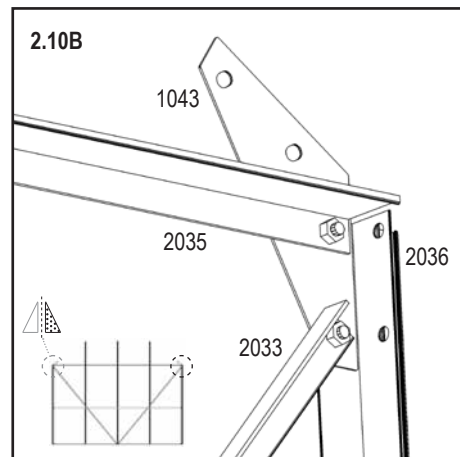
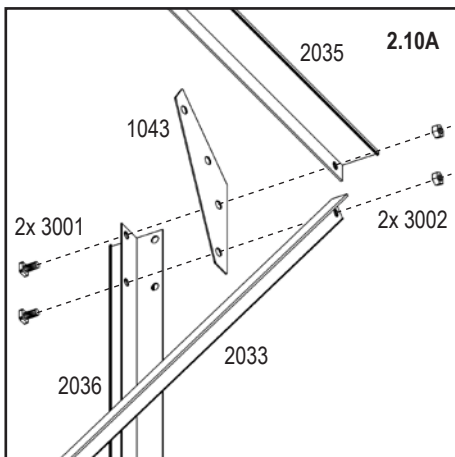
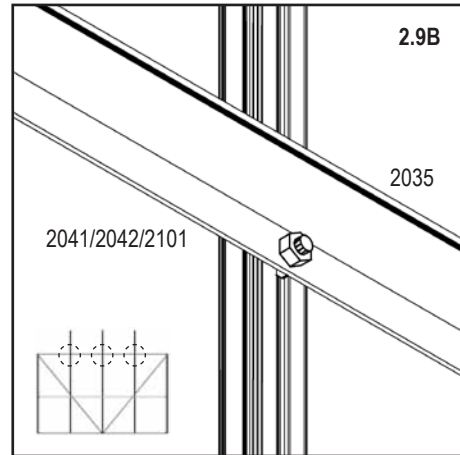
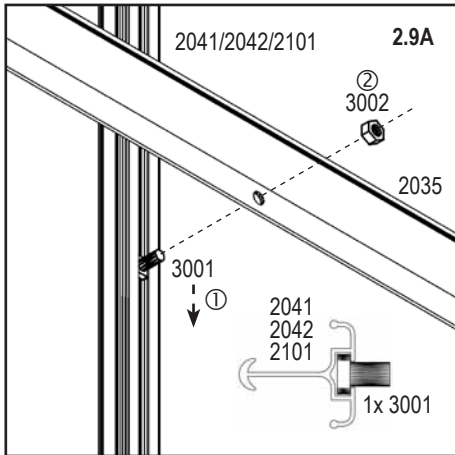

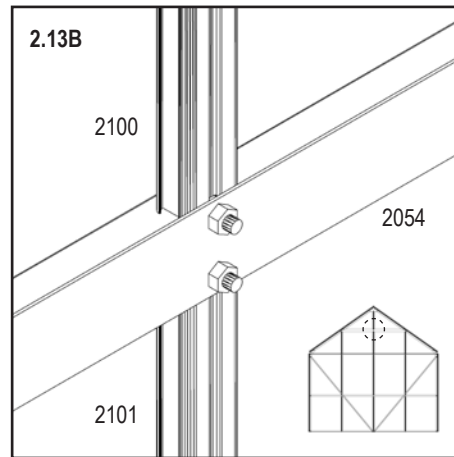
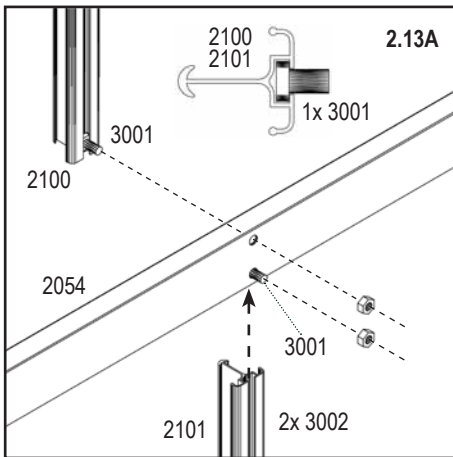
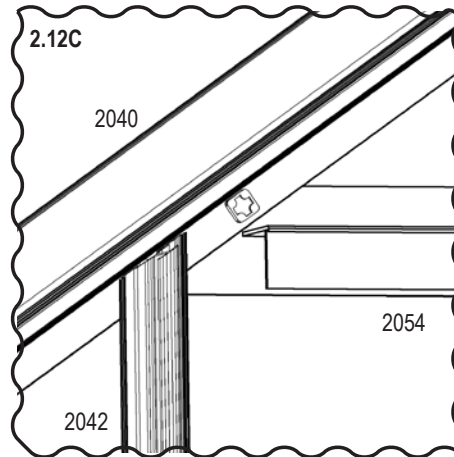
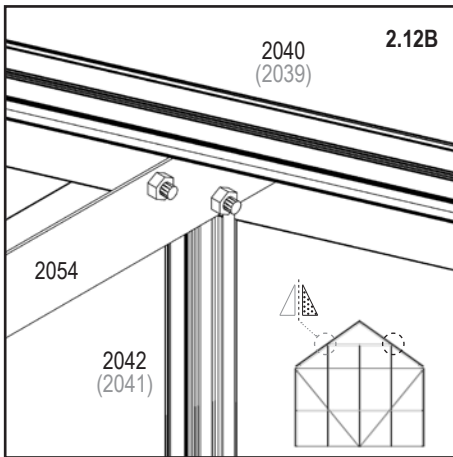
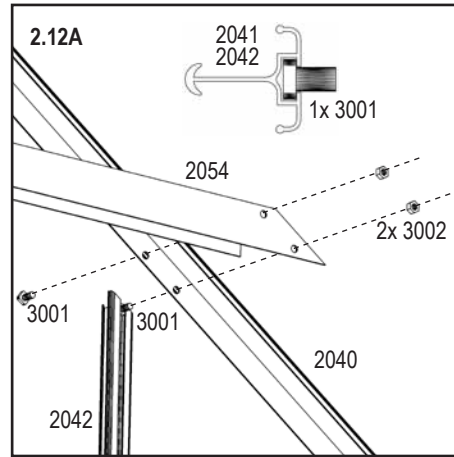
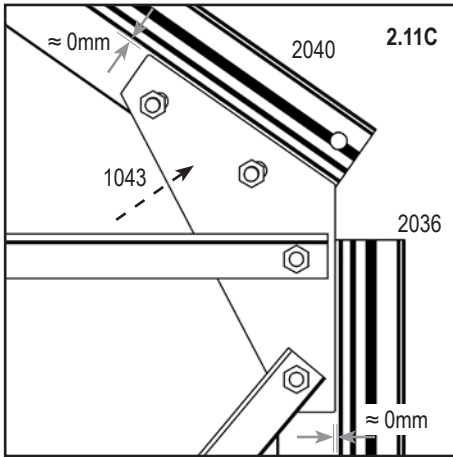

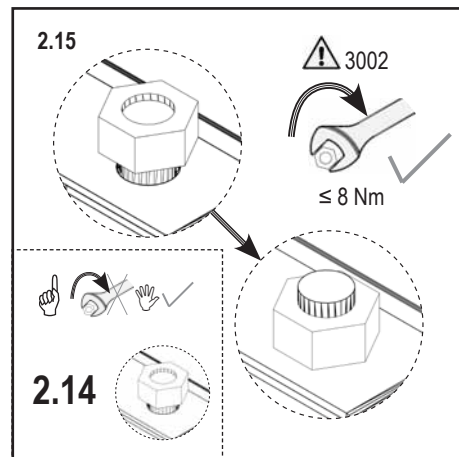
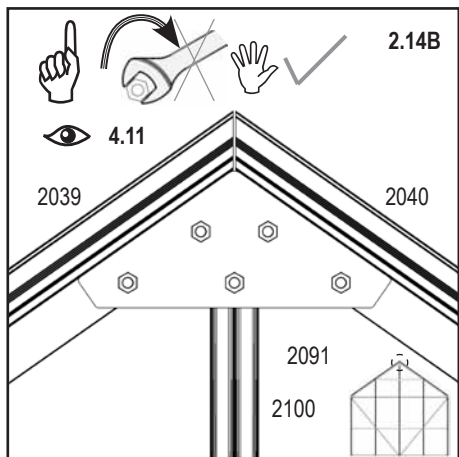
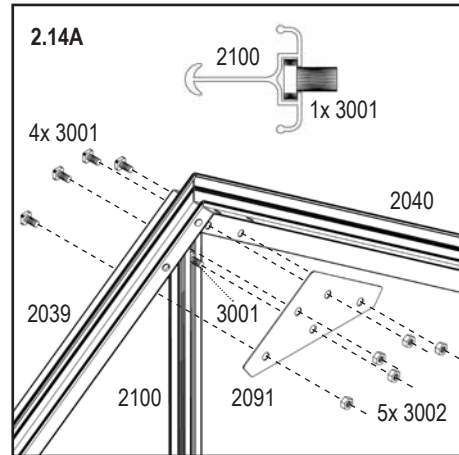
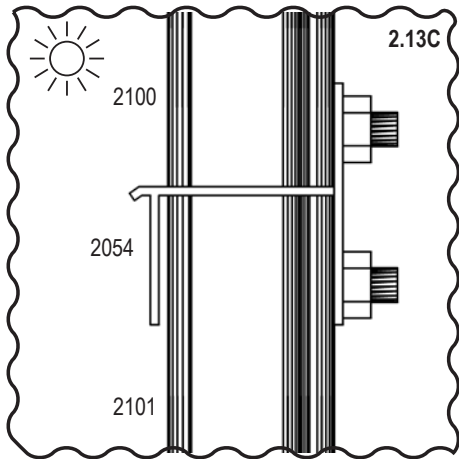

# 3

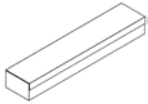
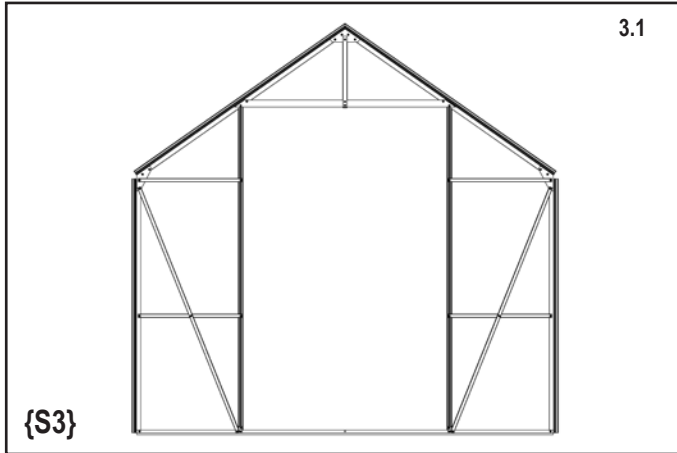
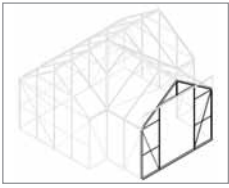

JUP,URA, 1/4 _SIR, 1/6 Front SL					
1043 2x		2046 1x		2091 1x	
2036 2x		2048 1x		2092 2x	
2039 1x		2075 1x		2094 1x	
2040 1x		2076 1x		2096 2x	
2041 1x		2089 1x		2100 1x	
2042 1x		2090 1x			

SIR,SLT,SSD, 2/6	
3001 35x	
3002 35x	

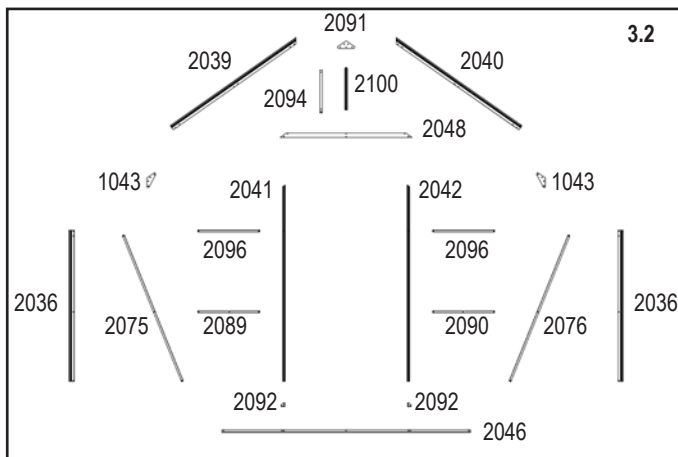

# 3

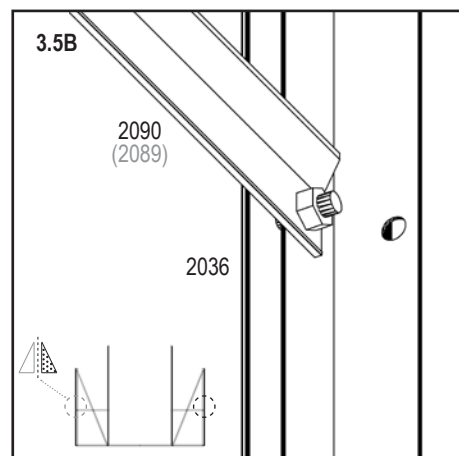
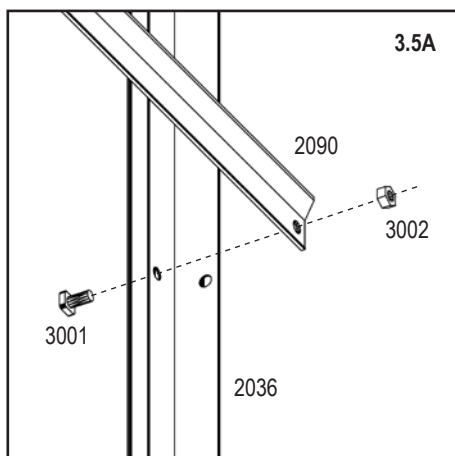
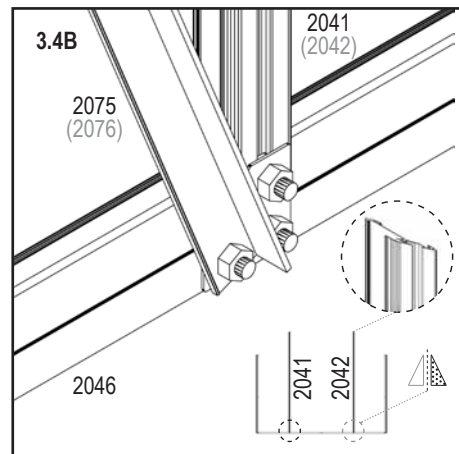
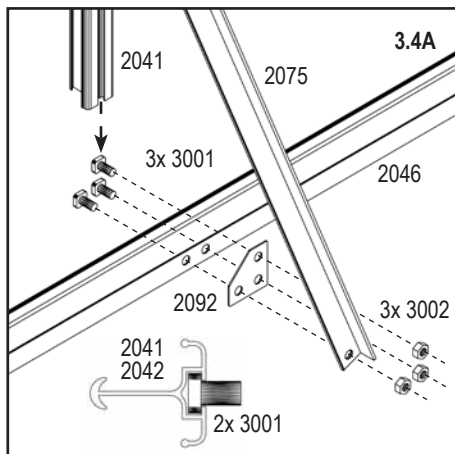
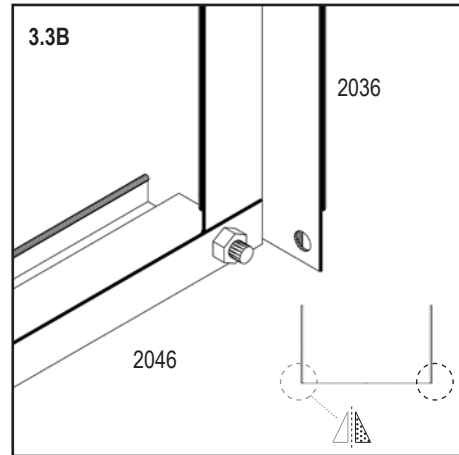
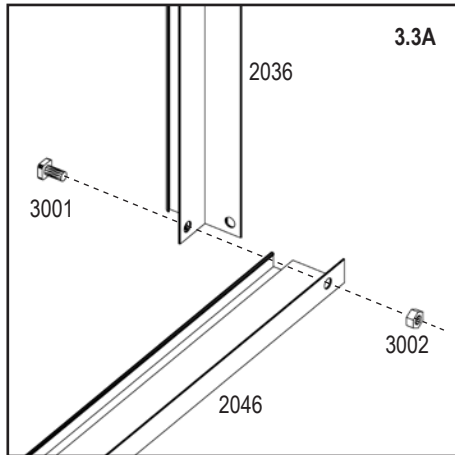
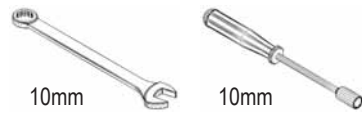
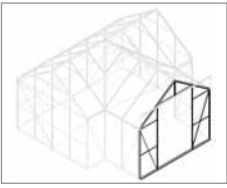



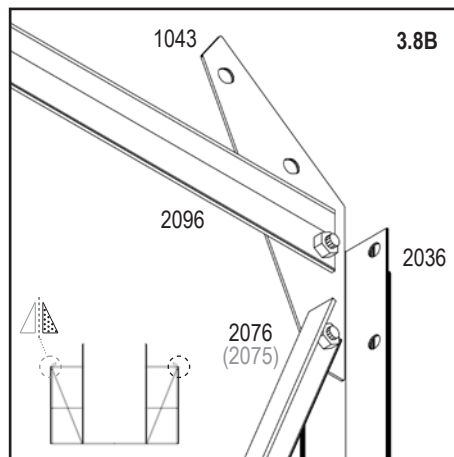
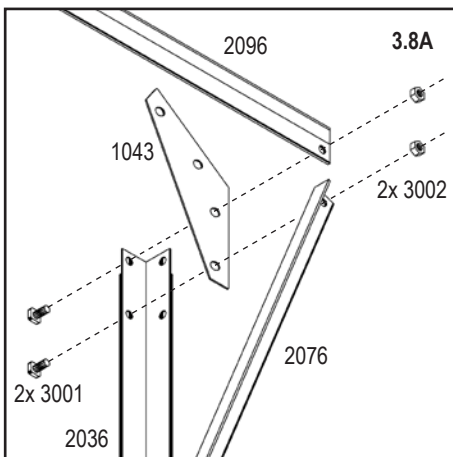
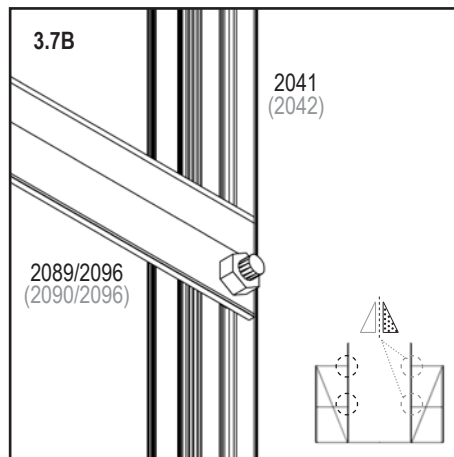
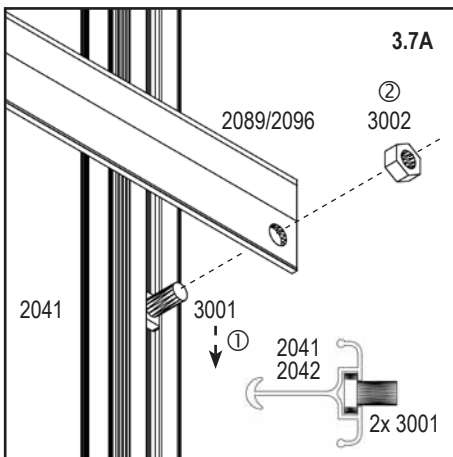
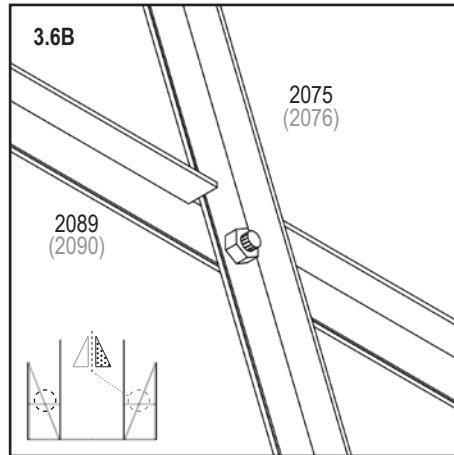
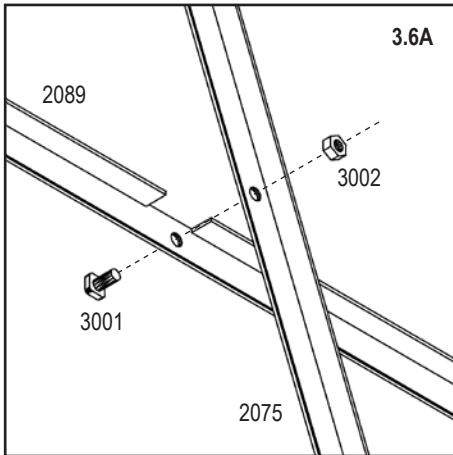

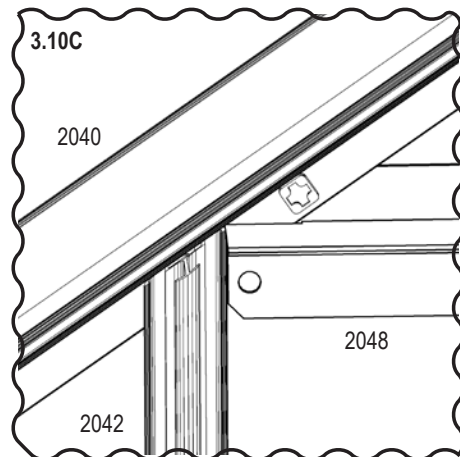
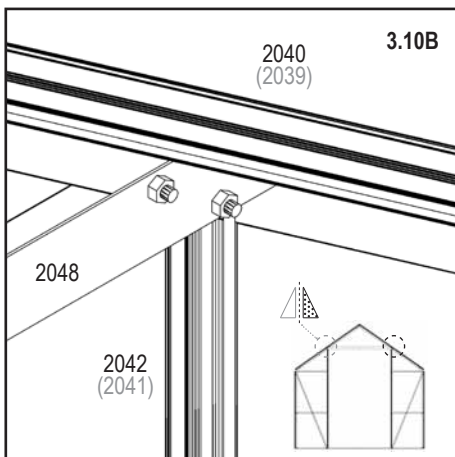
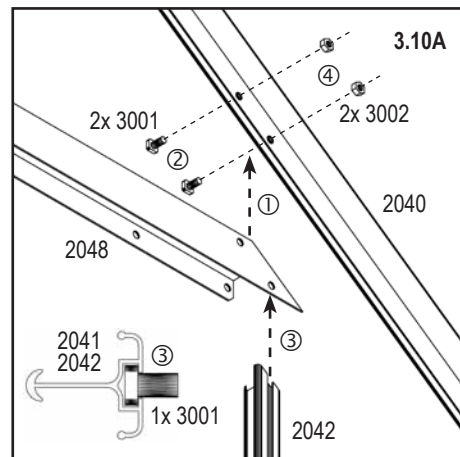
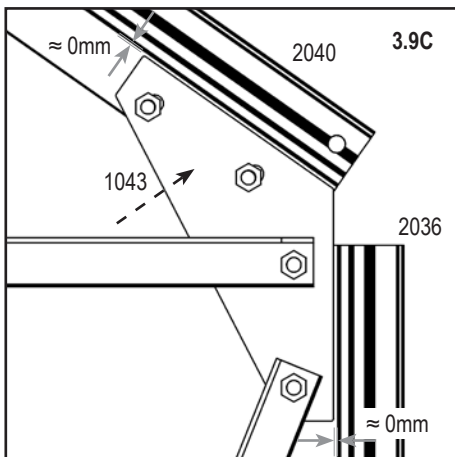
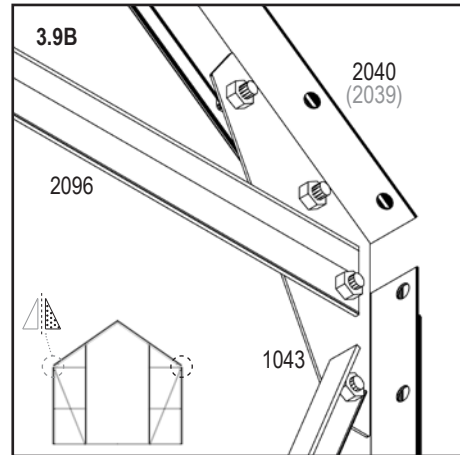
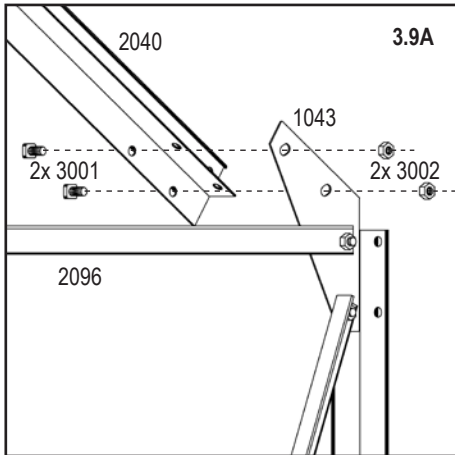
# 3



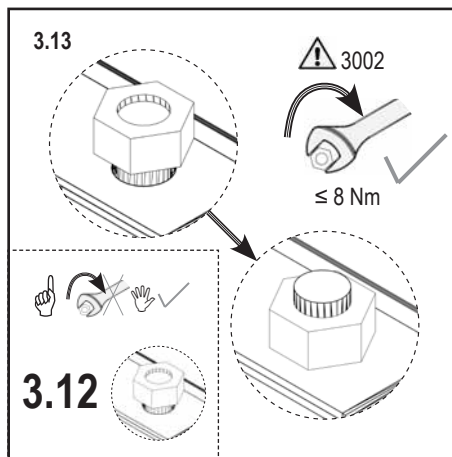
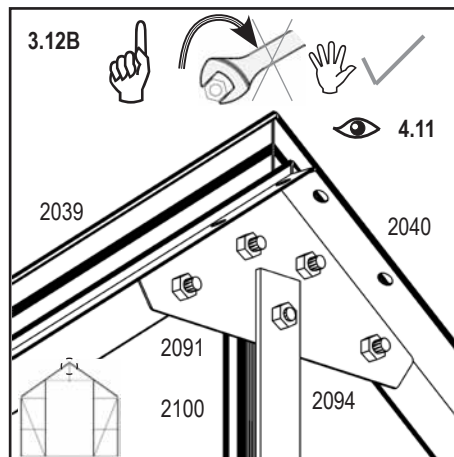
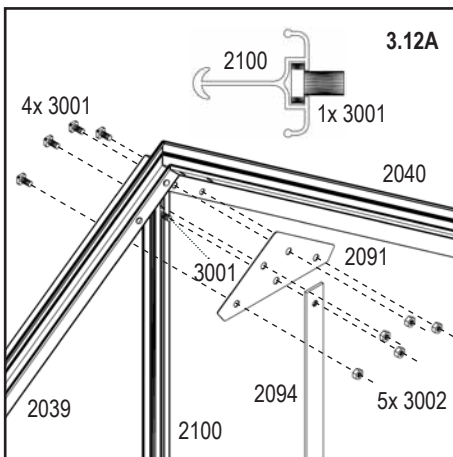
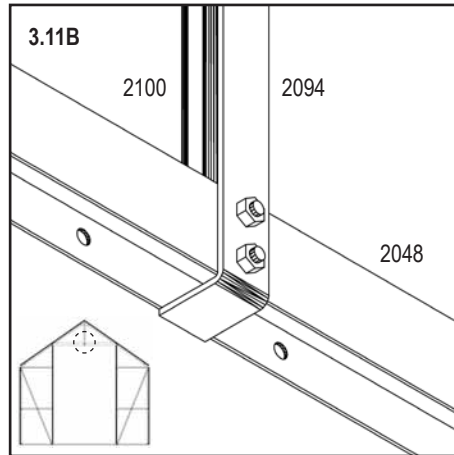
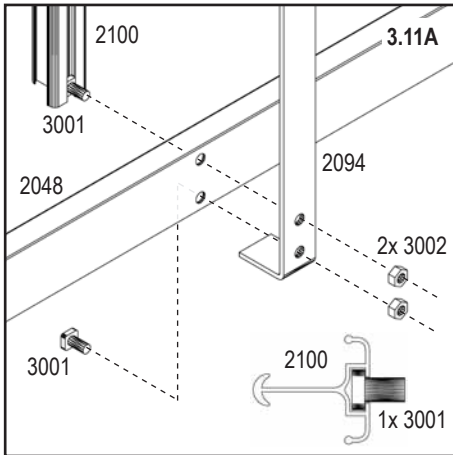

# 3



 Go to 
  Important Tip 
  Adjust by Hand

# 4

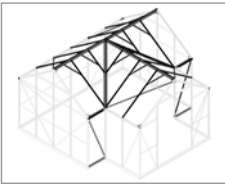

4.1

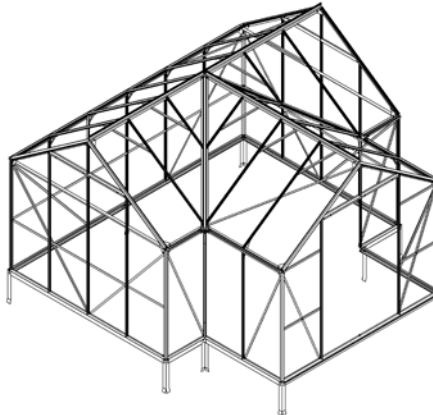

{S4}

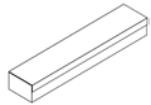

SIR,SLT,SSD, 2/6			
1018 12x		2519 2x	
1020 2x		3001 135x	
1092 14x		3002 136x	
2055 7x		3003 1x	
2513 2x		3057 7x	
2514 2x		9002 32x	

SIR,SLT,SSD, 4/6					
2033 2x		2509 2x		2516 2x	
2501 1x		2510 2x		2517 1x	
2502 1x		2511 1x		2518 1x	
2503 1x		2512 1x			
2504 1x		2515 2x			

4.2

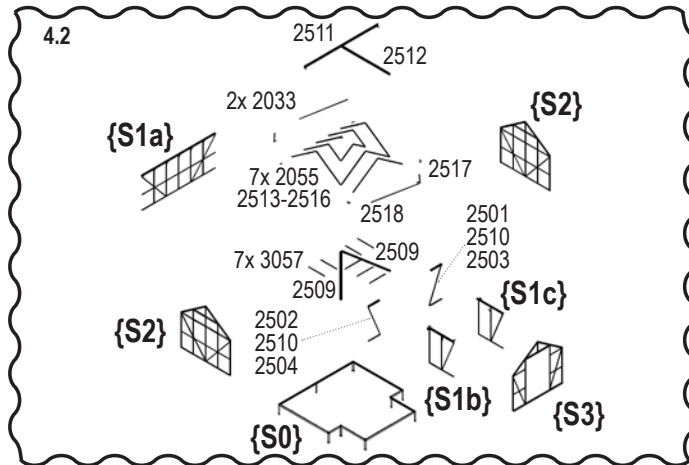

*			
{S0} 1x		{S1c} 1x	
{S1a} 1x		{S2} 2x	
{S1b} 1x		{S3} 1x	

# 4\_1

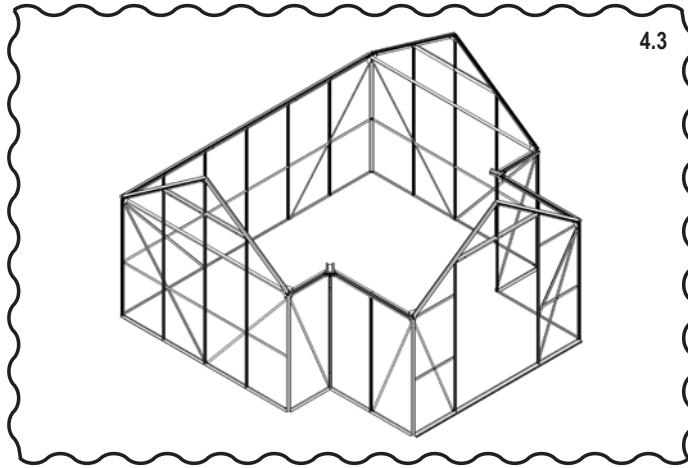
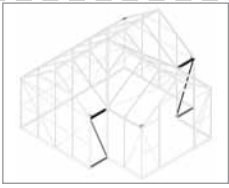

1092 8x		2510 2x		{S1a} 1x	
2501 1x		3001 38x		{S1b} 1x	
2502 1x		3002 38x		{S1c} 1x	
2503 1x				{S2} 1x	
2504 1x				{S3} 1x	

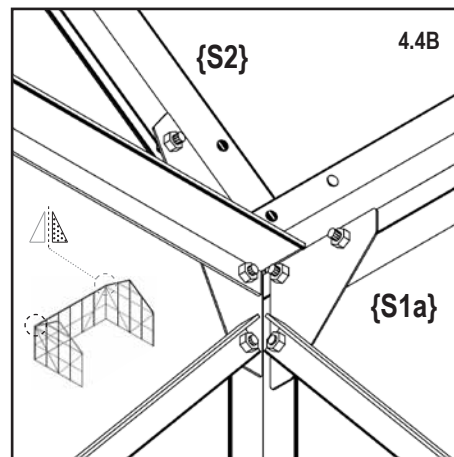
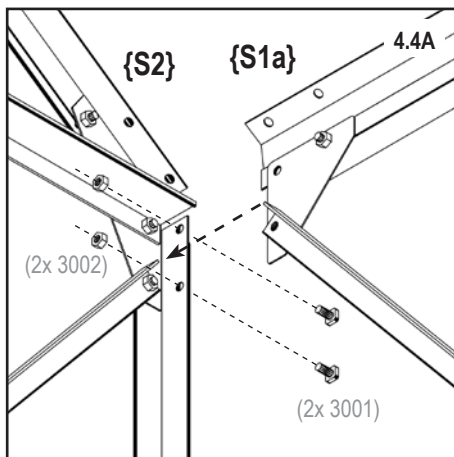

Mirror of



Persons required.

# 4\_1

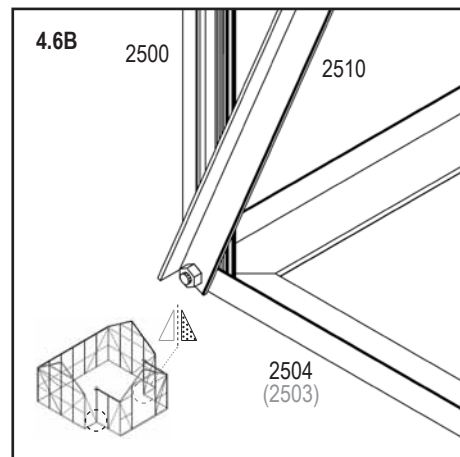
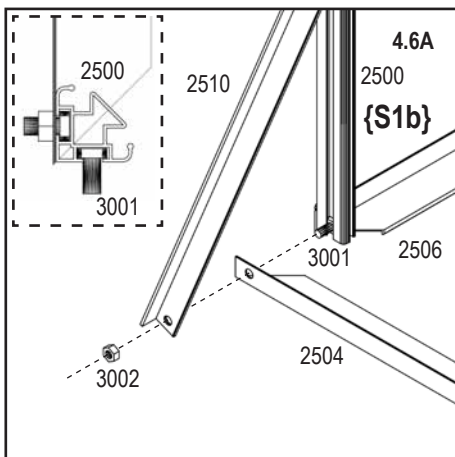
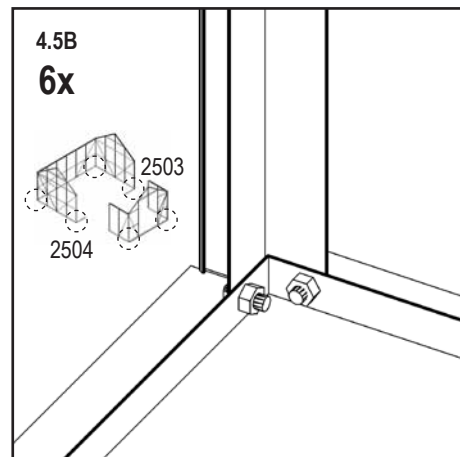
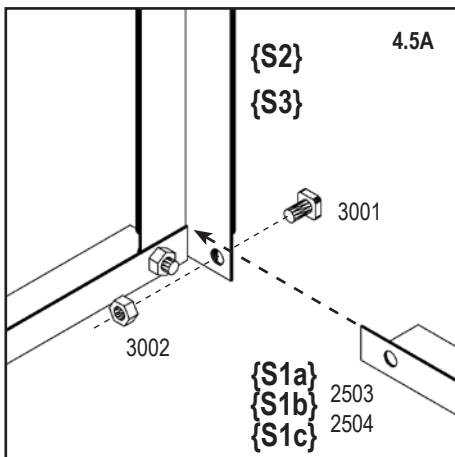
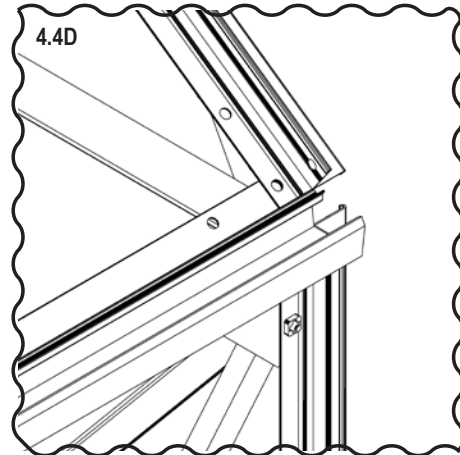
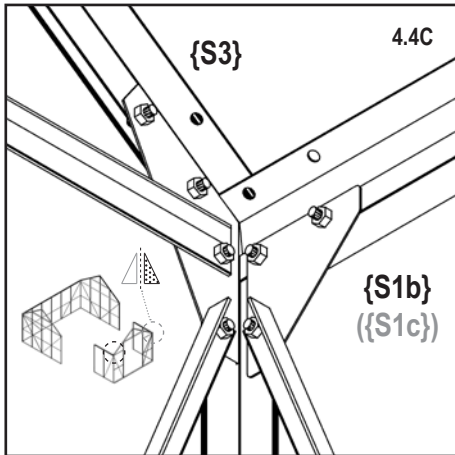

# 4\_1

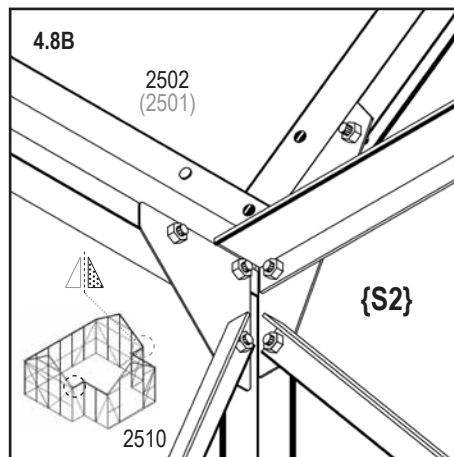
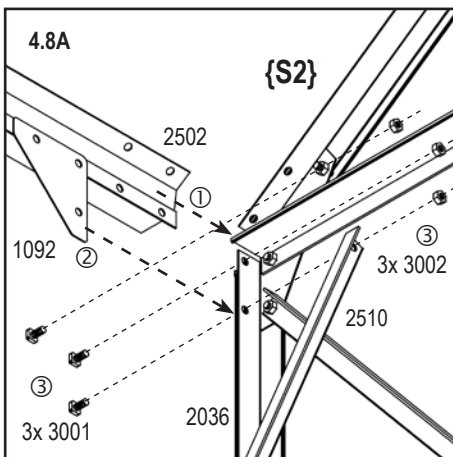
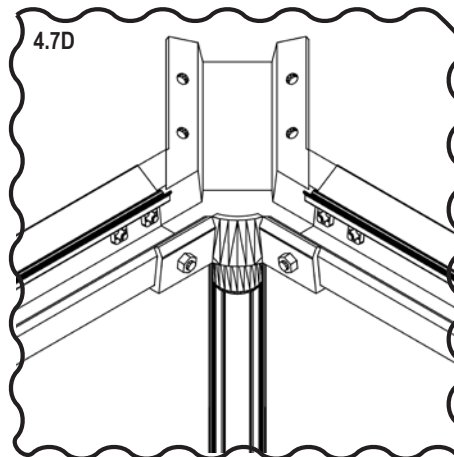
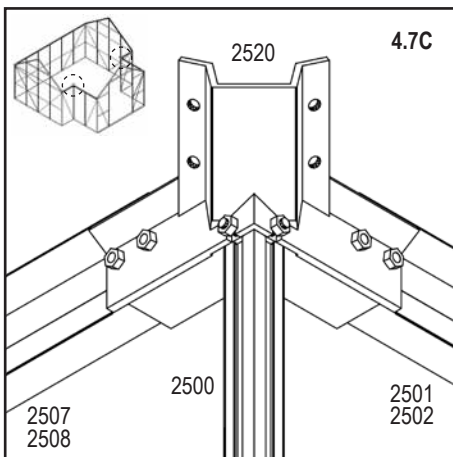
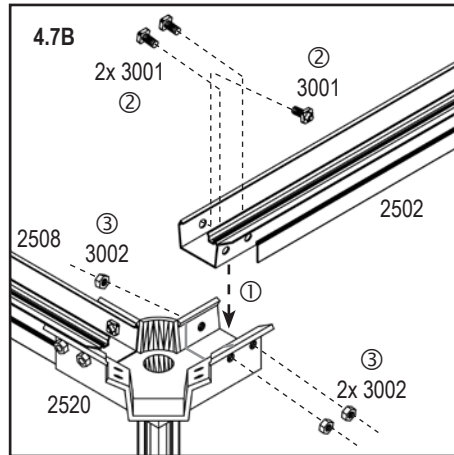
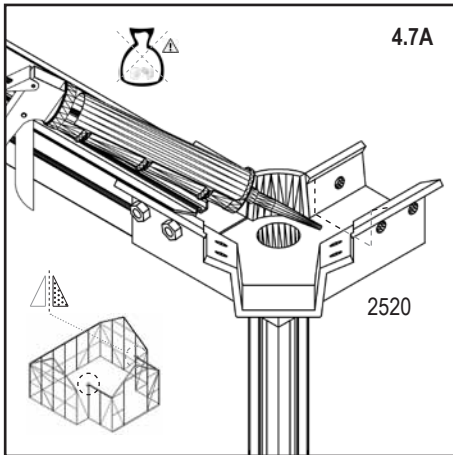

Not included in product!



Mirror of

# 4\_1

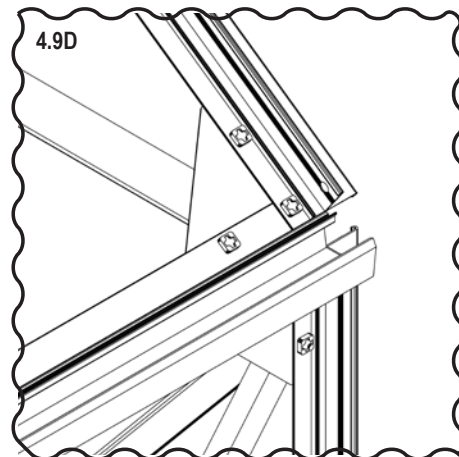
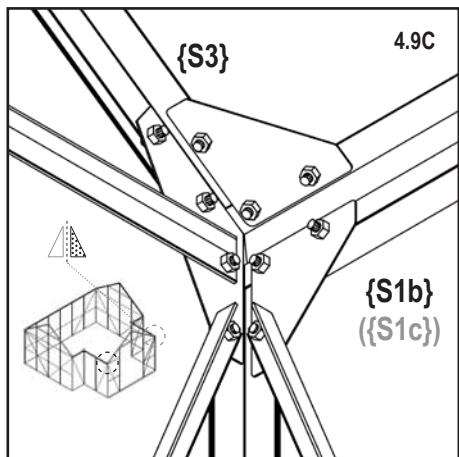
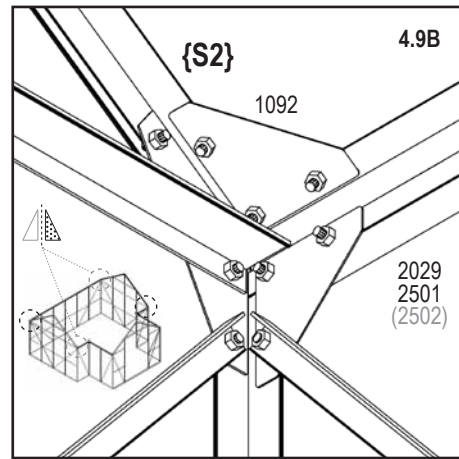
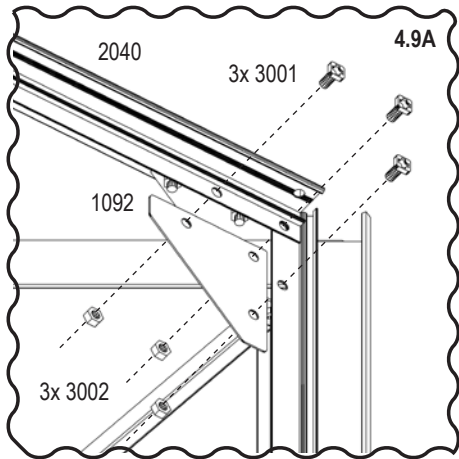

# 4\_2

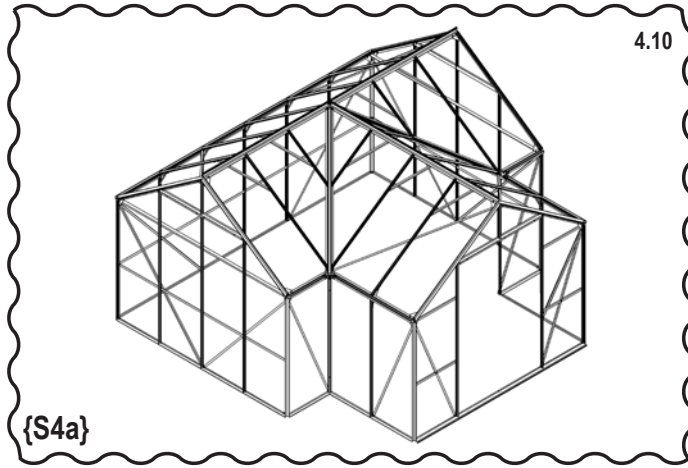
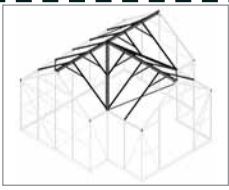

1018 12x		2509 2x		2515 2x		3001 97x	
1020 2x		2511 1x		2516 2x		3002 98x	
1092 6x		2512 1x		2517 1x		3003 1x	
2033 2x		2513 2x		2518 1x		3057 7x	
2055 7x		2514 2x		2519 2x			

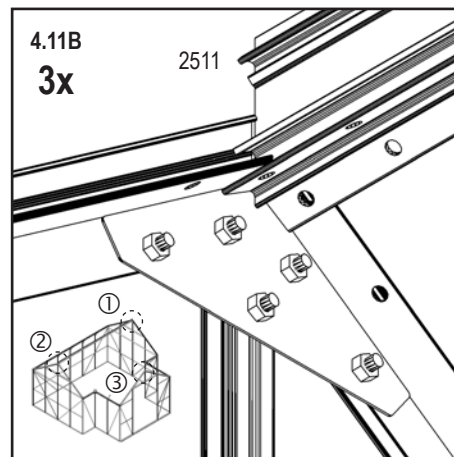
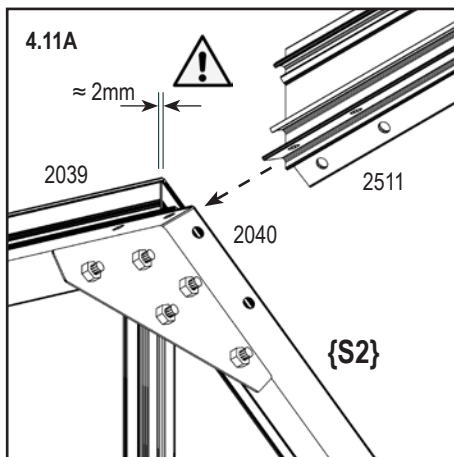

Important!



Persons required.

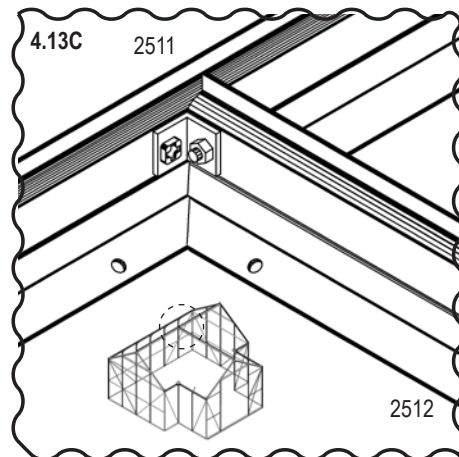
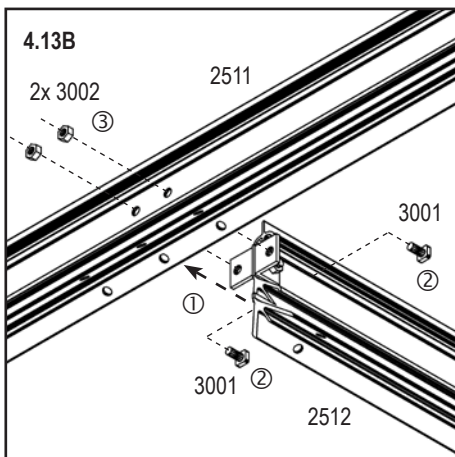
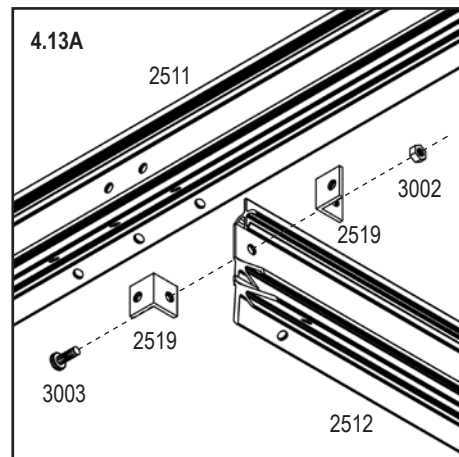
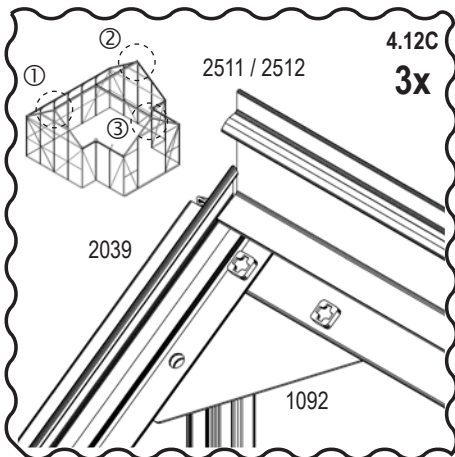
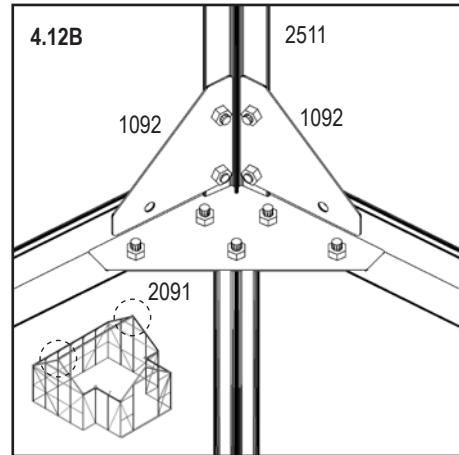
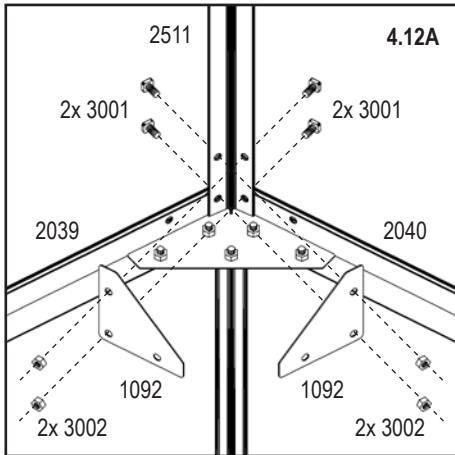

# 4\_2

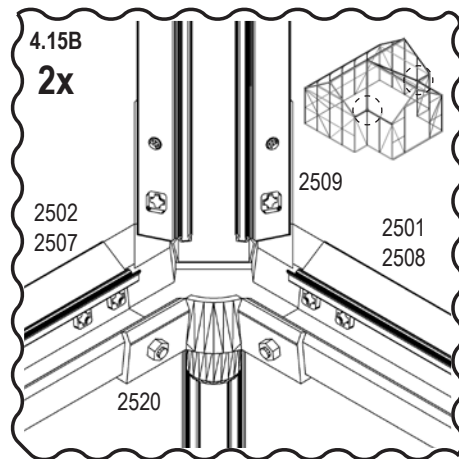
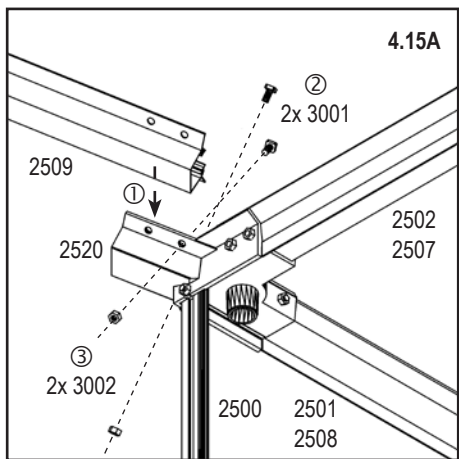
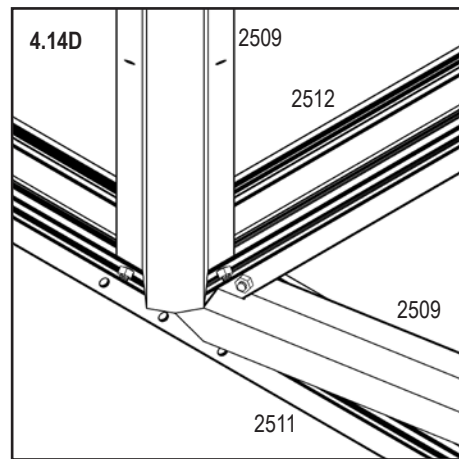
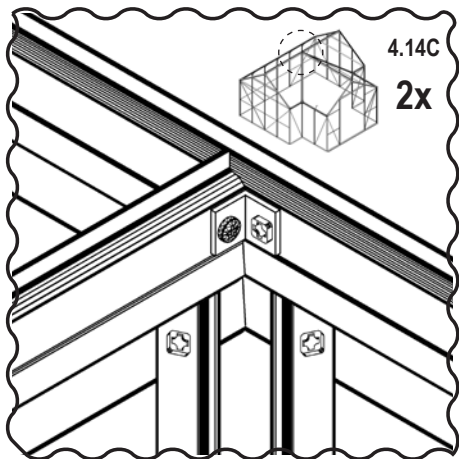
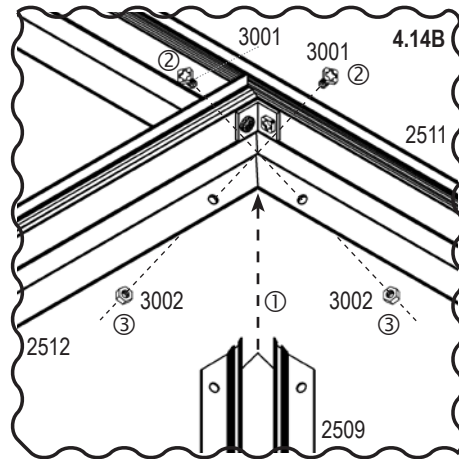
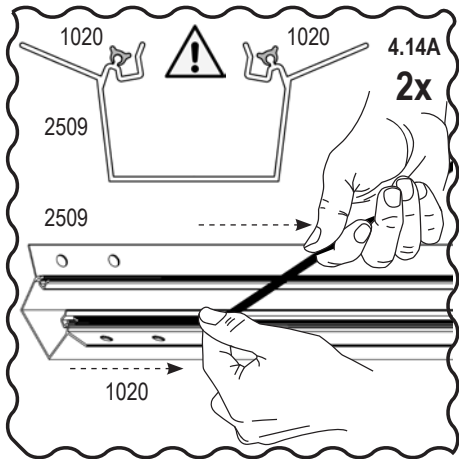

# 4\_2

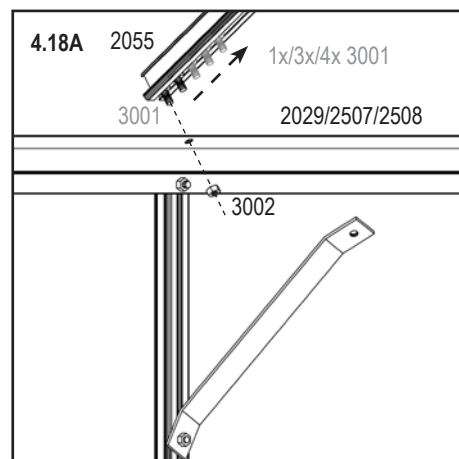
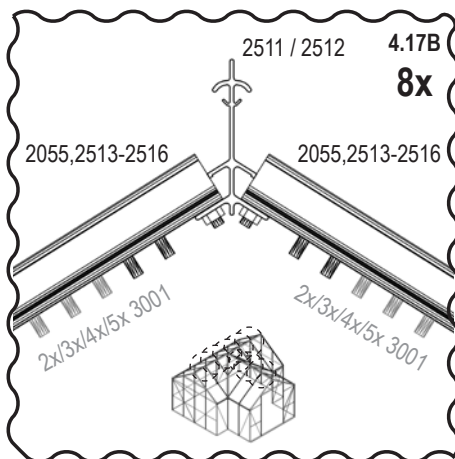
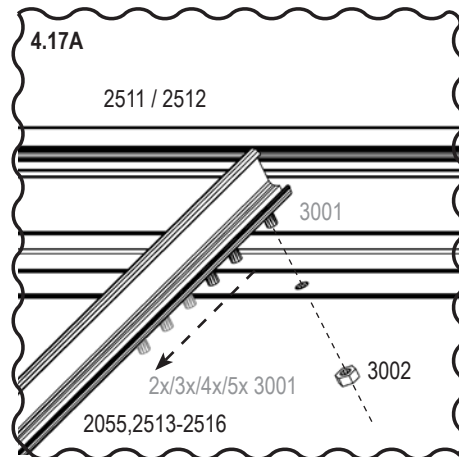
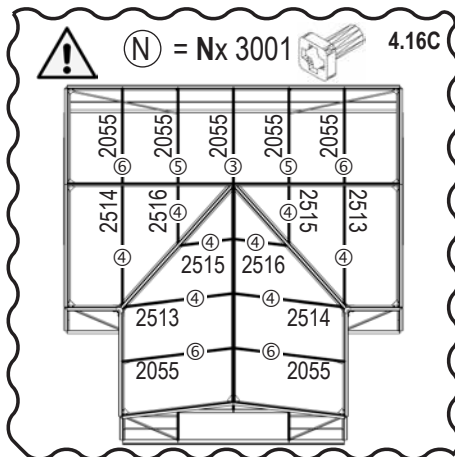
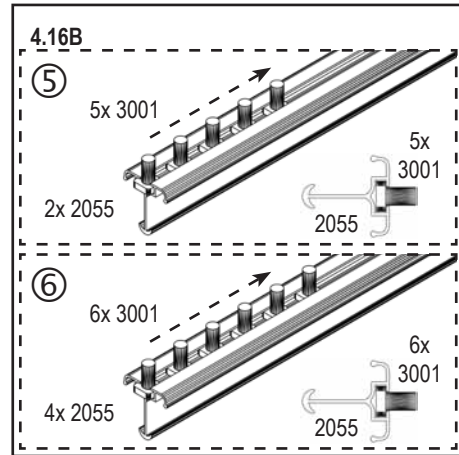
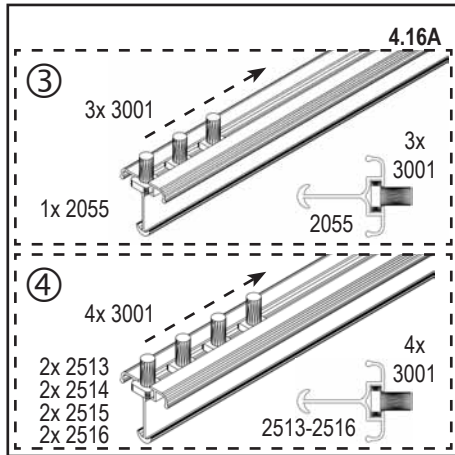

**!** Important!

# 4\_2

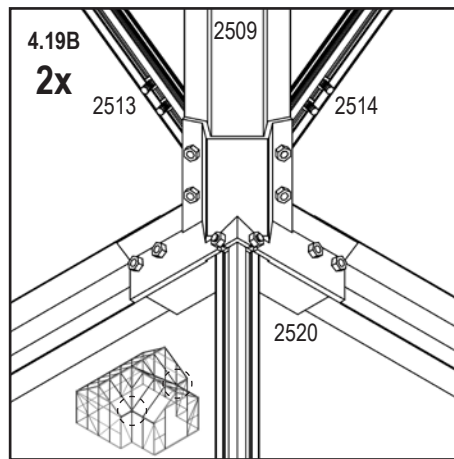
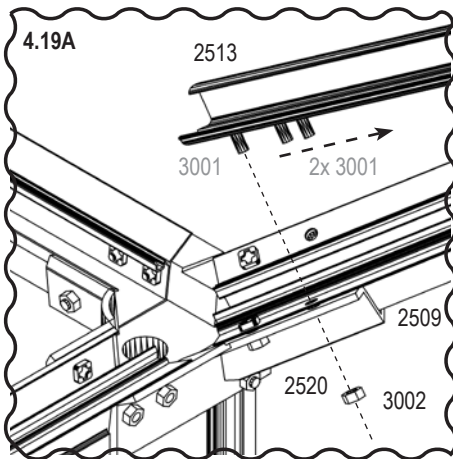
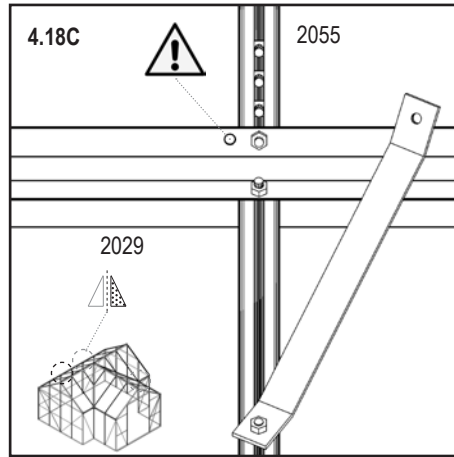
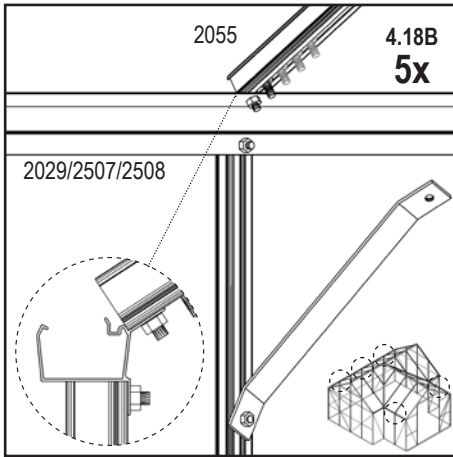

4.20B

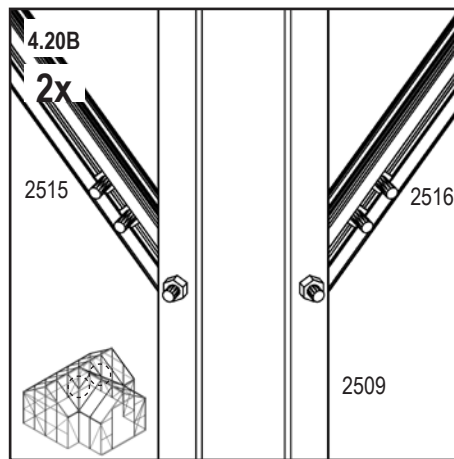
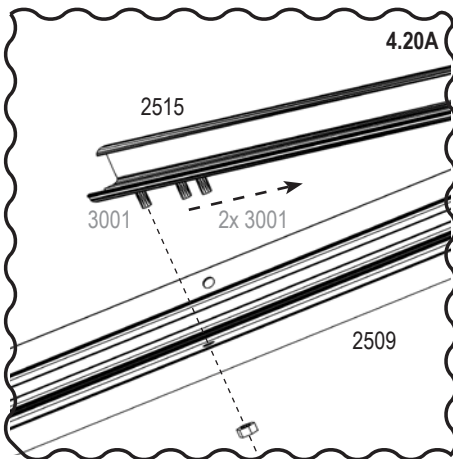

! Important!  Mirror of

# 4\_2

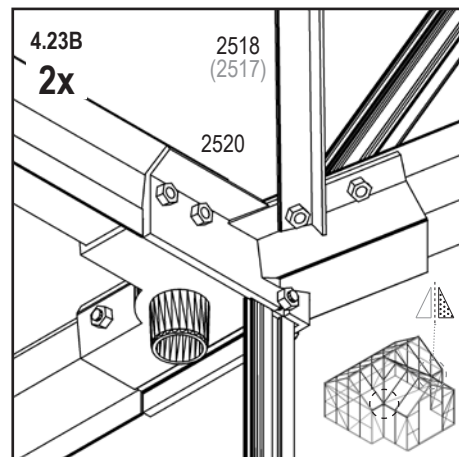
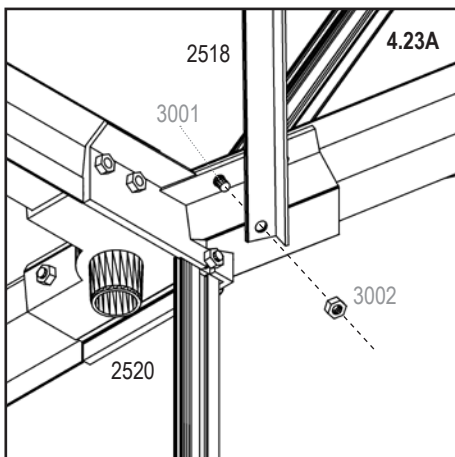
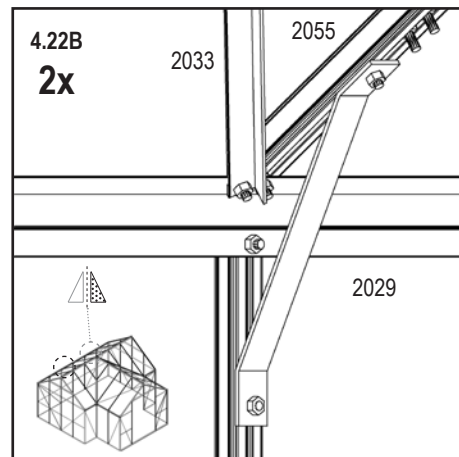
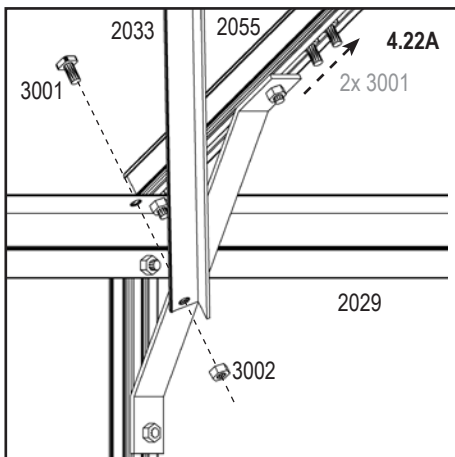
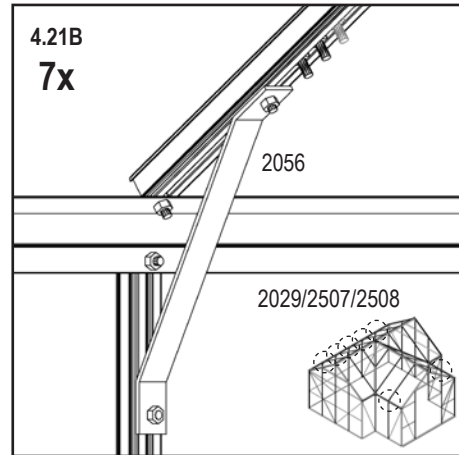
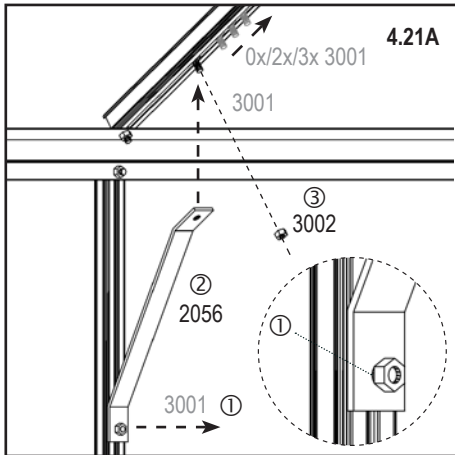

 Mirror of

# 4\_2

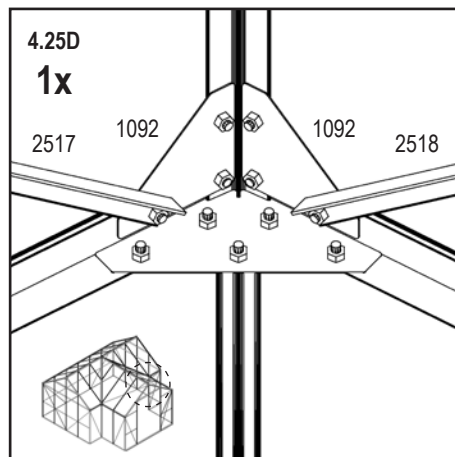
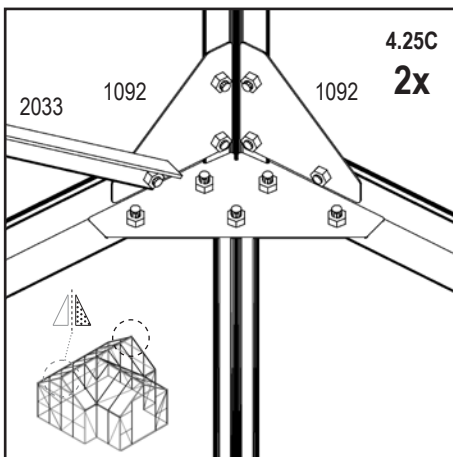
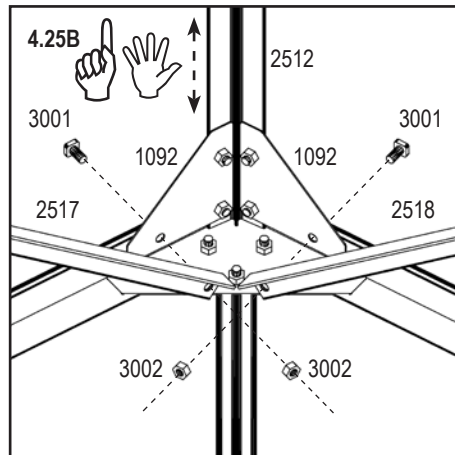
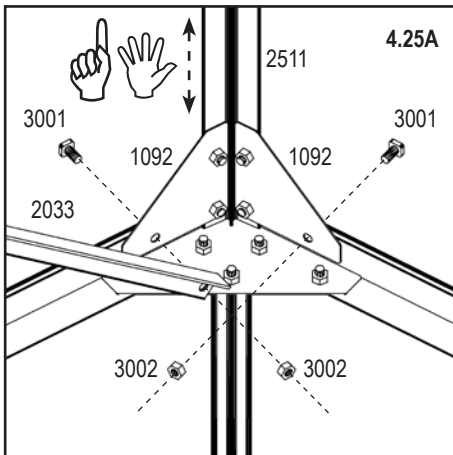
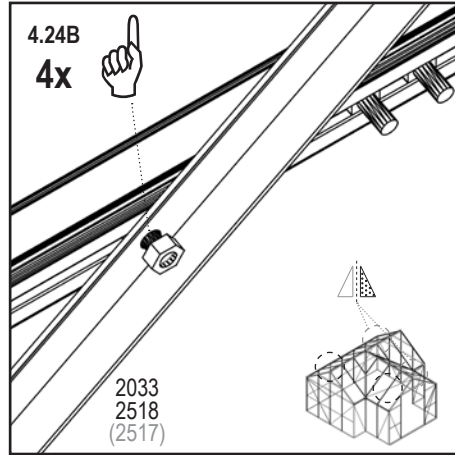
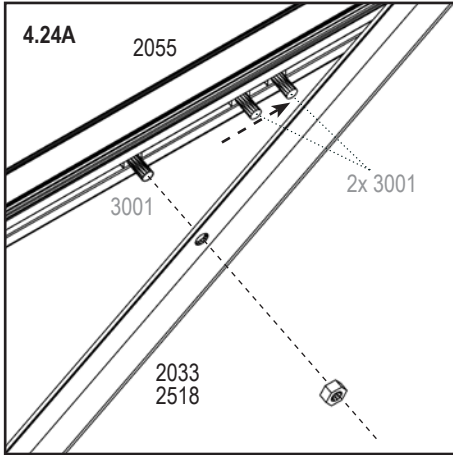

Important Tip
 Adjust by Hand
 Mirror of

# 4\_2

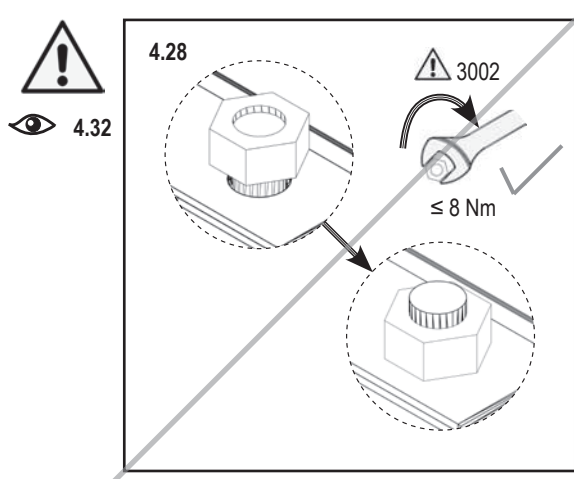
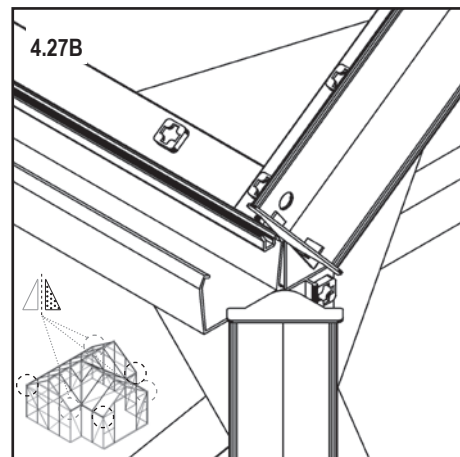
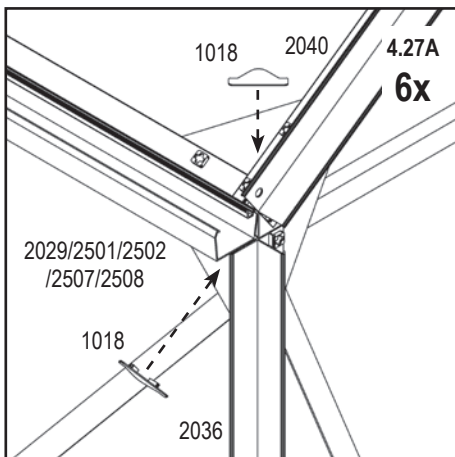
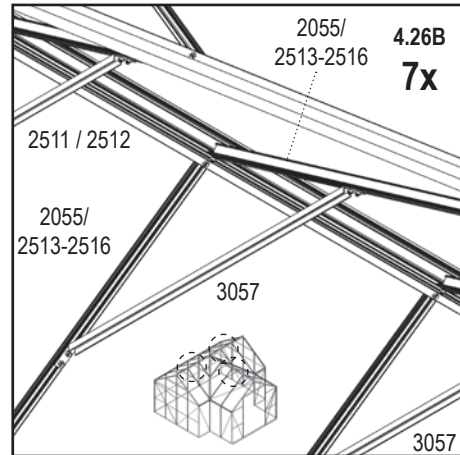
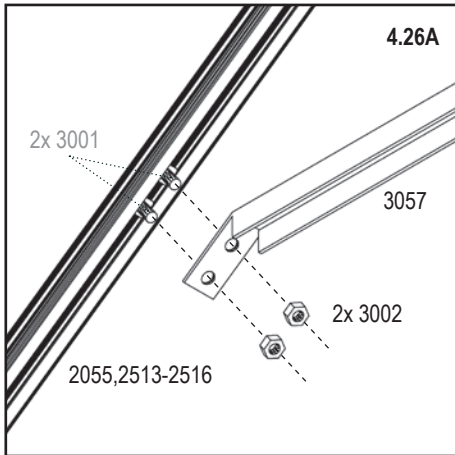

! Important! □ Step for later 👁 Go to 🏠 Mirror of

# 4\_3

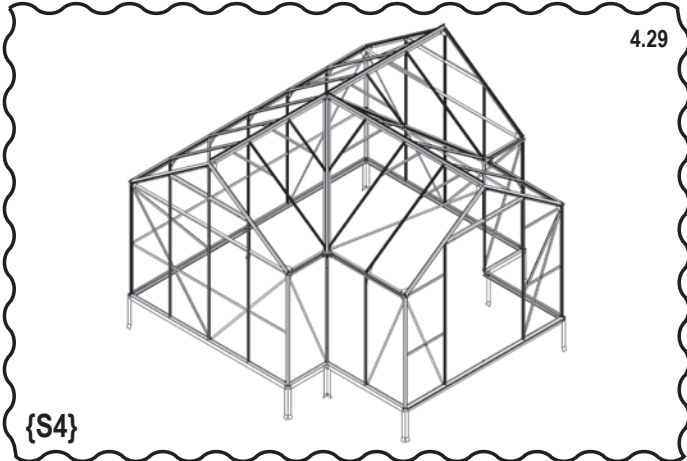



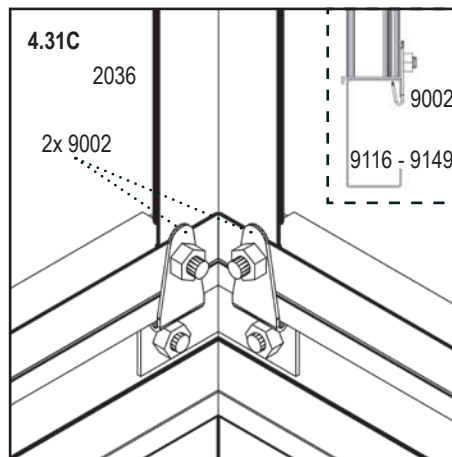
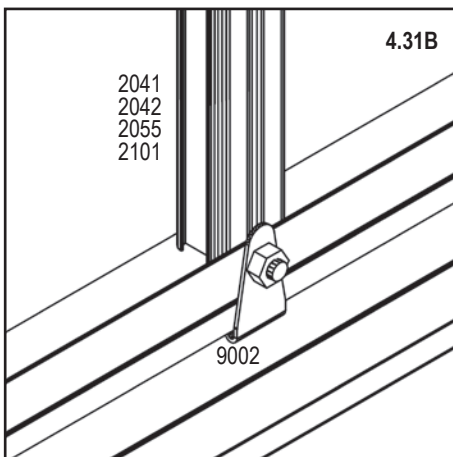
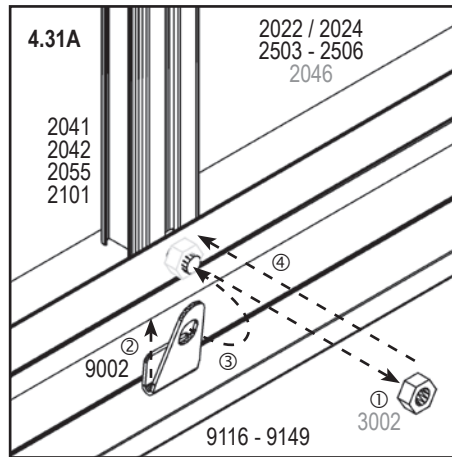
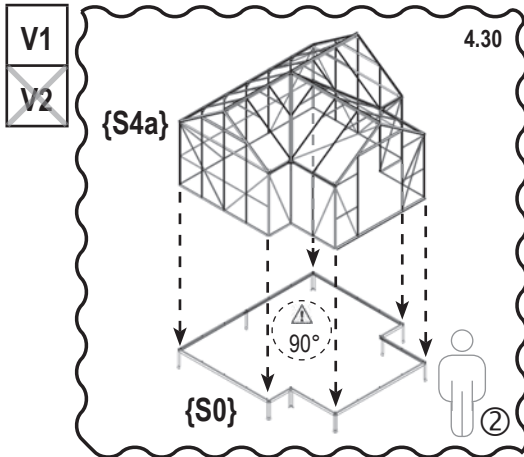



9002 32x	
{S0} 1x	
{S4a} 1x	

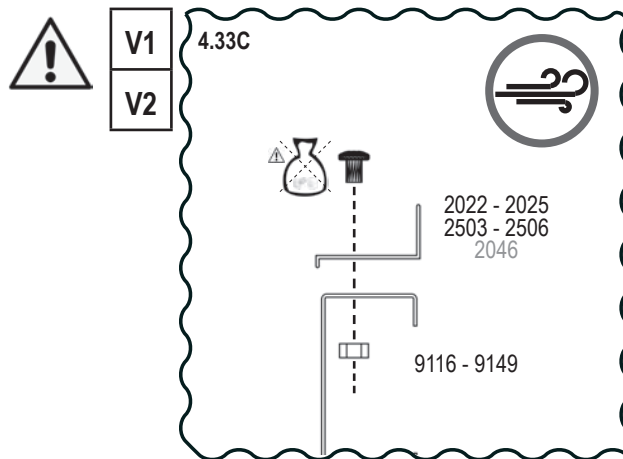
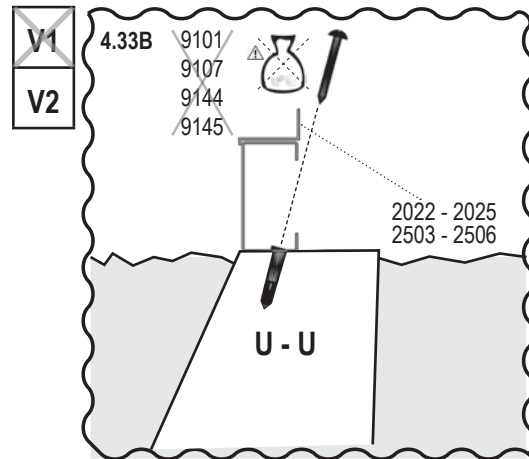
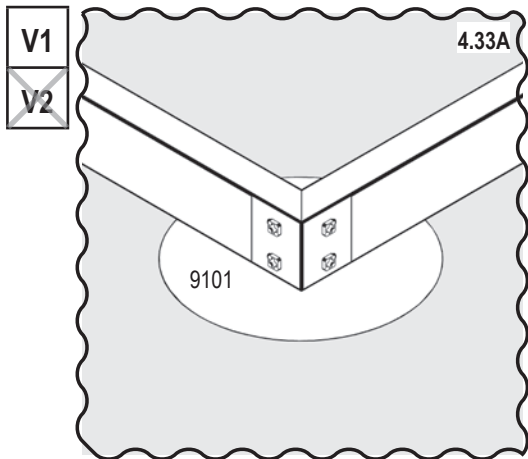
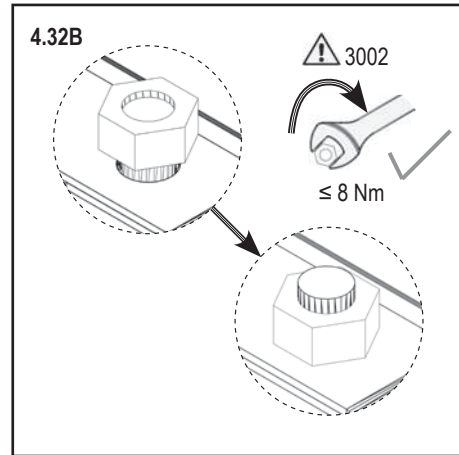
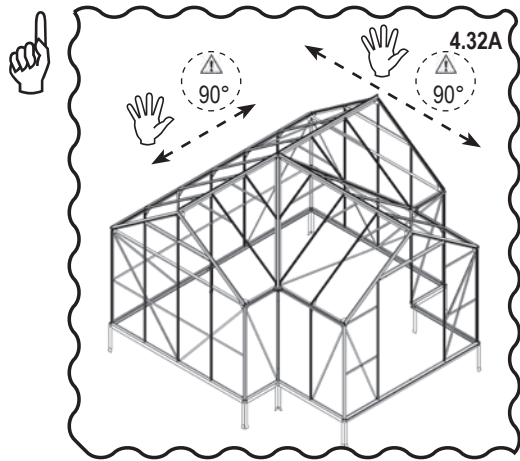

Persons required. Exactly square

# 4\_3



 Important Tip
  Adjust by Hand
  Exactly square
  Important!
  High Wind

# 5

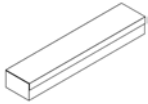
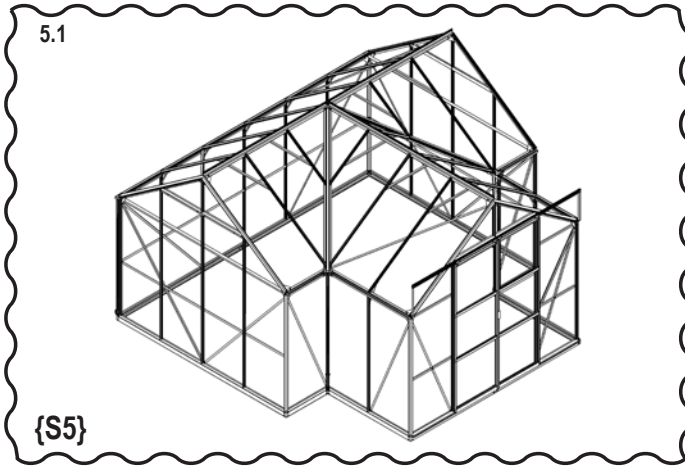
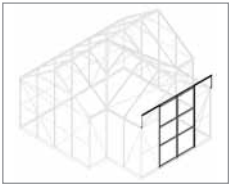

JUP,URA, 1/4 _SIR, 1/6 Front SL			
1002 2x		4201 2x	
1310 2x		5001 1x	
1347 2x		5002 1x	
2043 2x		6060 2x	
3001 8x		7399 1x	
3002 9x			

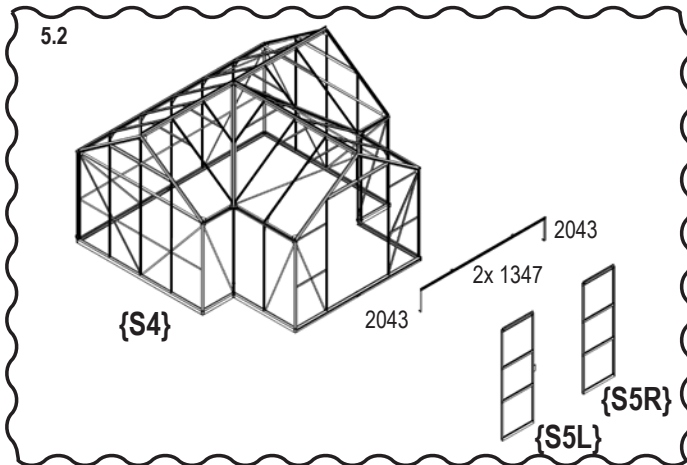

*	
{S4} 1x	
{S5L} 1x	
{S5R} 1x	

# 5\_1L

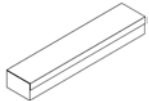
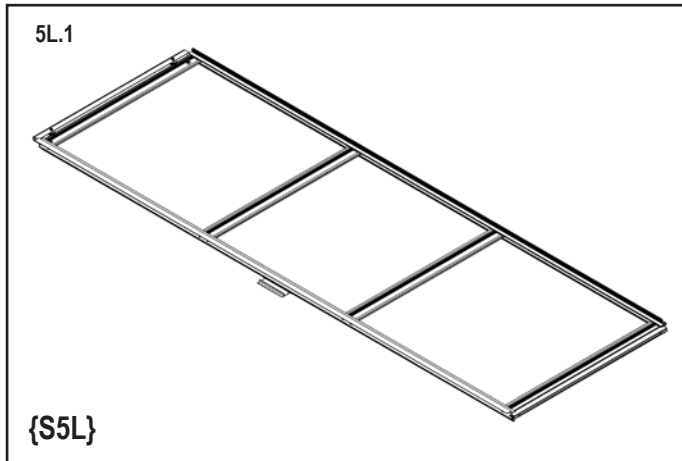
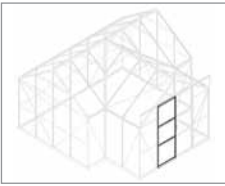

JUP,URA, 1/4 _SIR, 1/6 Front SL							
1003 16x		1304 2x		1500 1x		2058 1x	
1007 2x		1359 1x		1515 1x		2098 1x	
1009 2x		1360 1x		2005 1x		3001 2x	
1014 2x		1361 2x		2006 2x		3002 2x	
1015 2x		1362 1x		2021 1x			

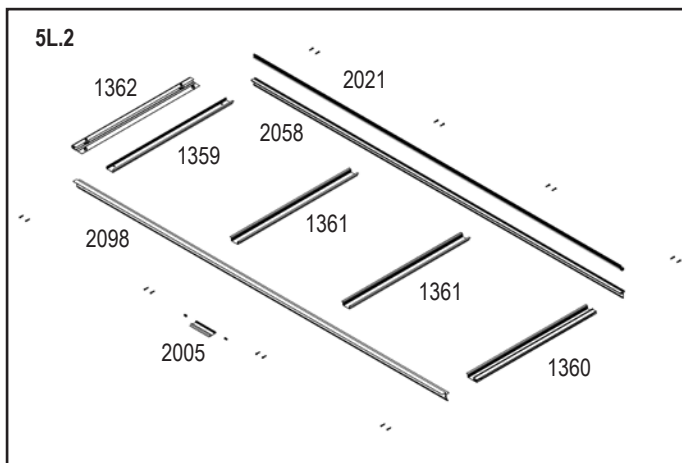

# 5\_1L

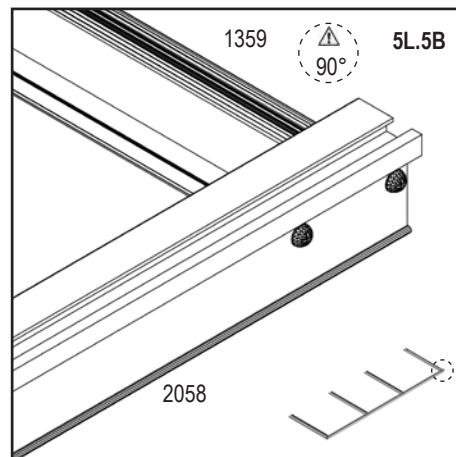
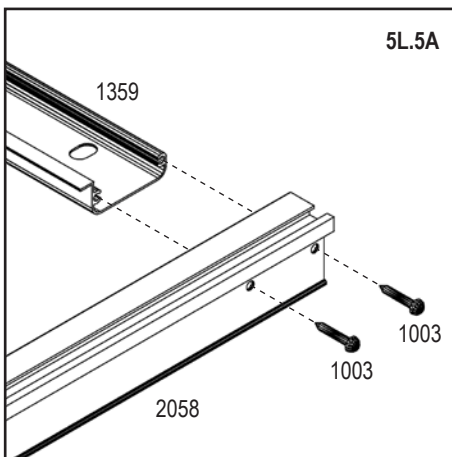
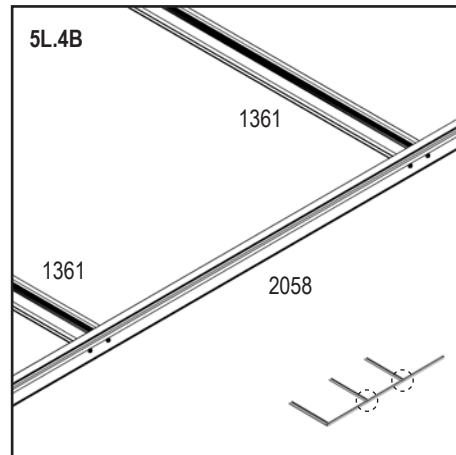
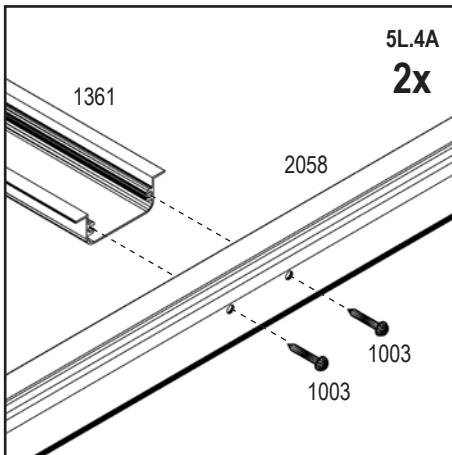
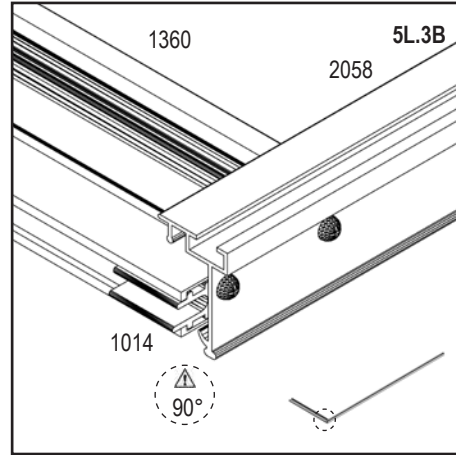
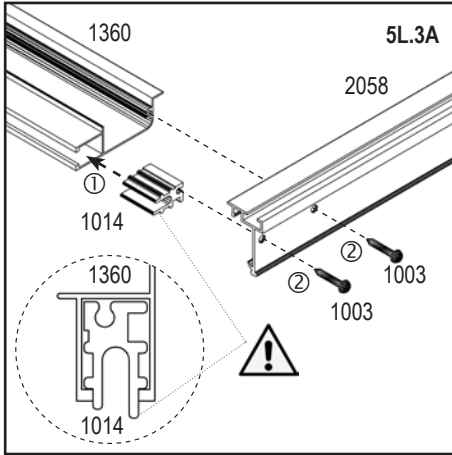
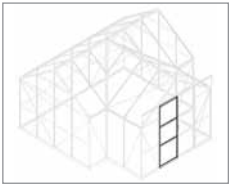

Important! Go to Exactly square

# 5\_1L

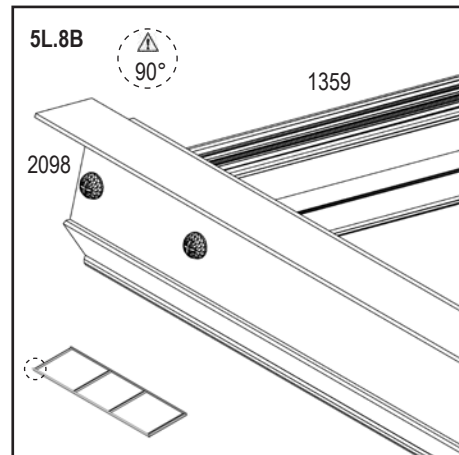
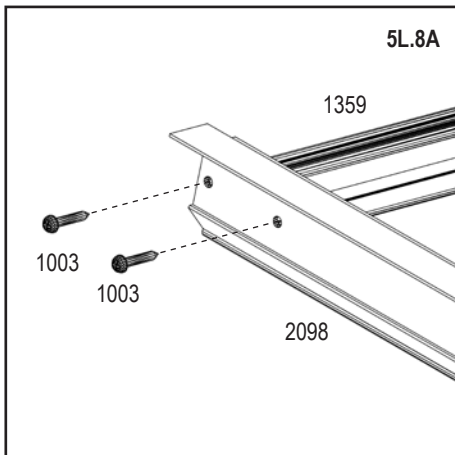
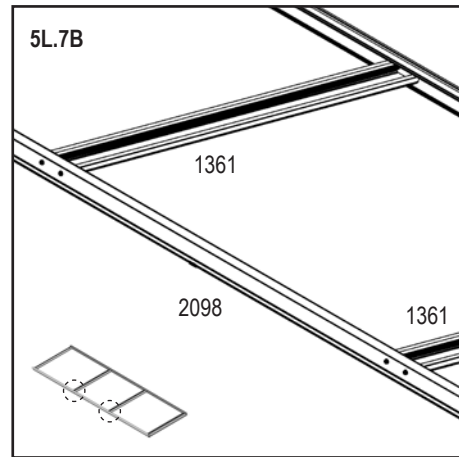
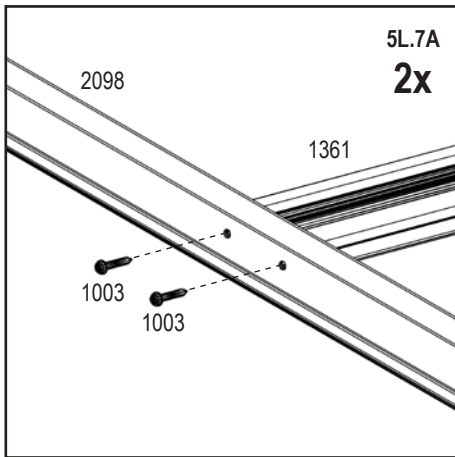
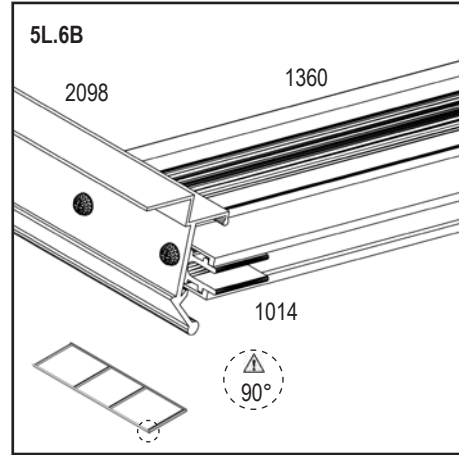
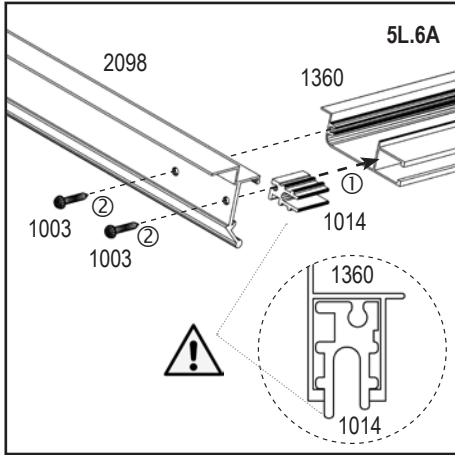

! Important! Exactly square

# 5\_1L

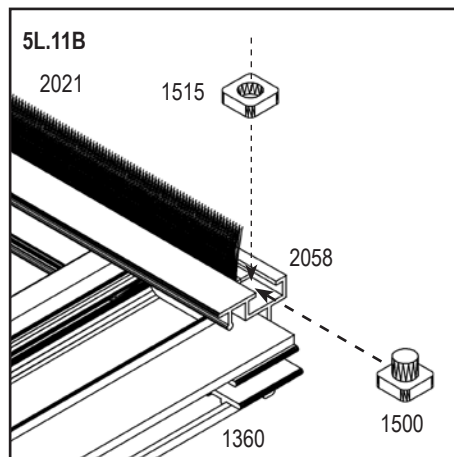
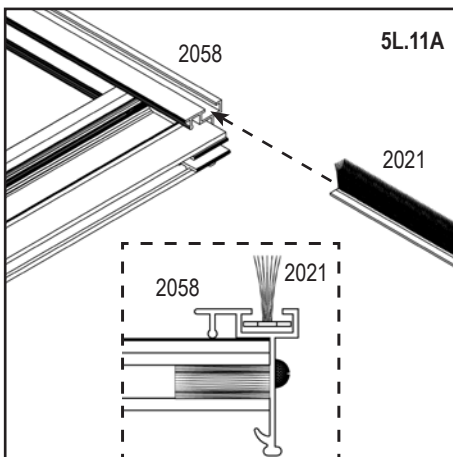
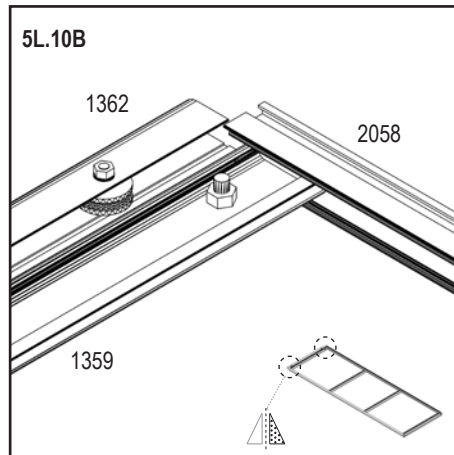
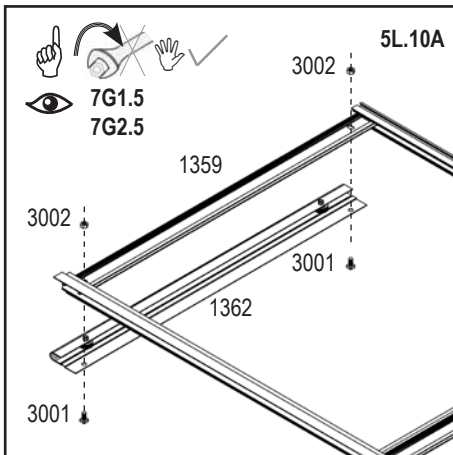
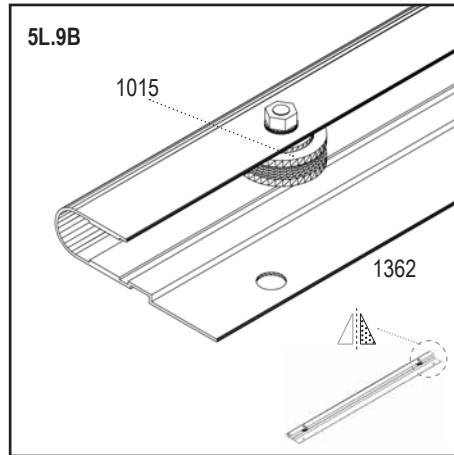
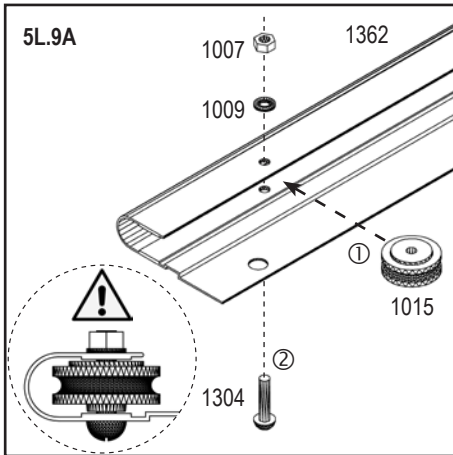

 Important! 
  Important Tip 
  Adjust by Hand 
  Mirror of

# 5\_1L

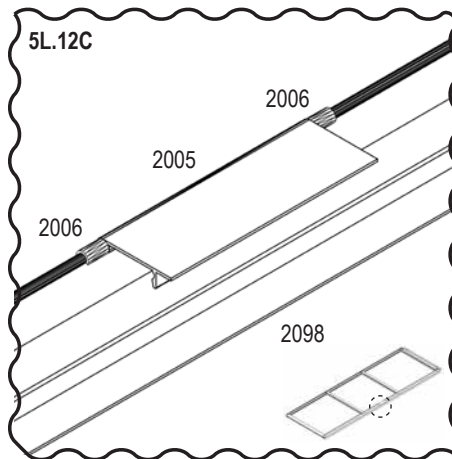
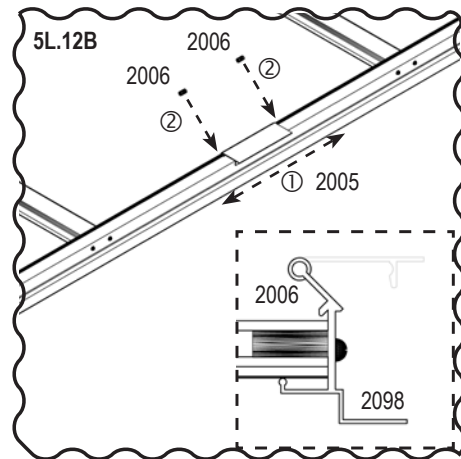
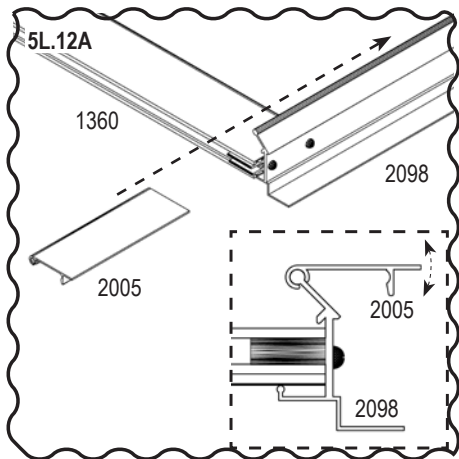
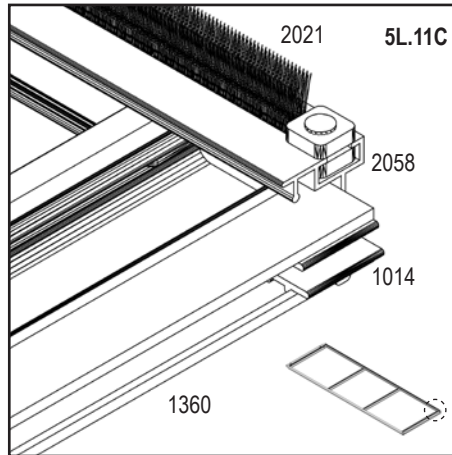

# 5\_1R

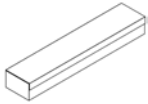
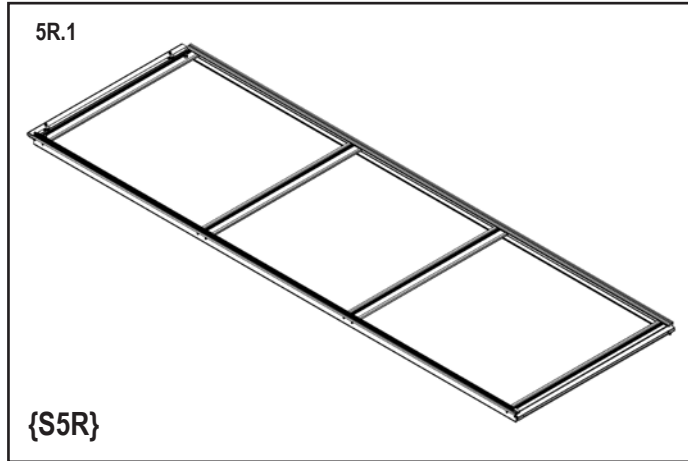
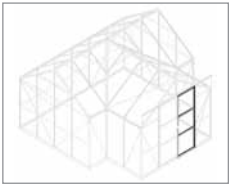

JUP,URA, 1/4 _SIR, 1/6 Front SL							
1003 16x		1304 2x		1500 1x		3001 2x	
1007 2x		1359 1x		1515 1x		3002 2x	
1009 2x		1360 1x		2021 1x			
1014 2x		1361 2x		2058 1x			
1015 2x		1362 1x		2099 1x			

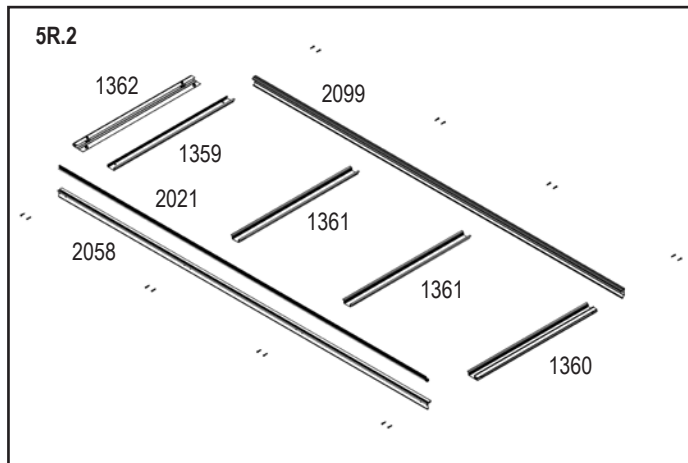

# 5\_1R

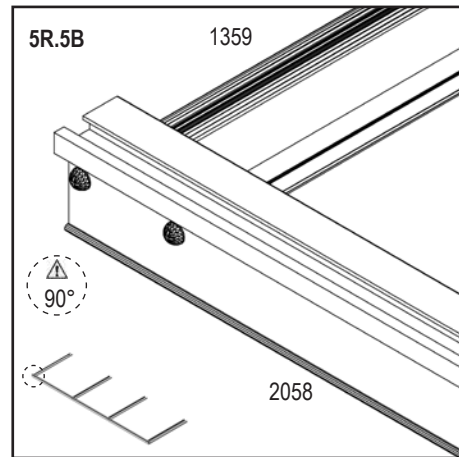
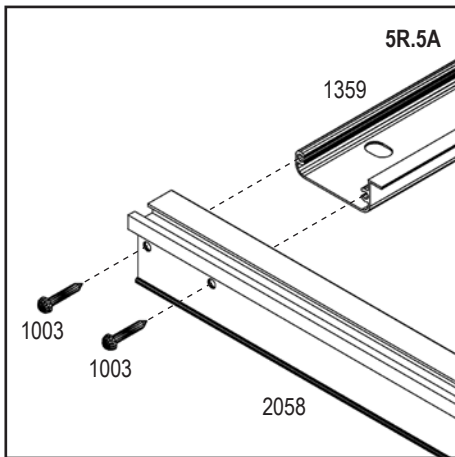
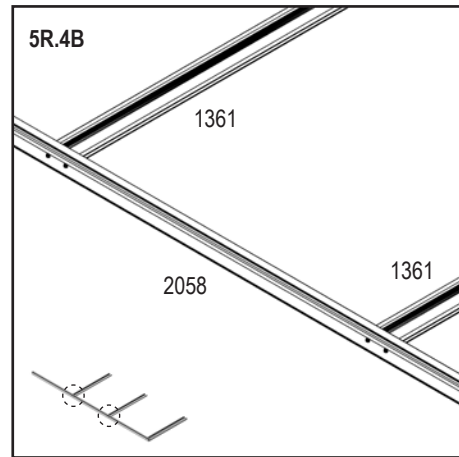
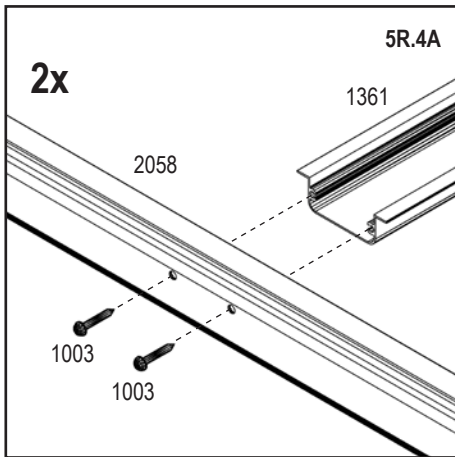
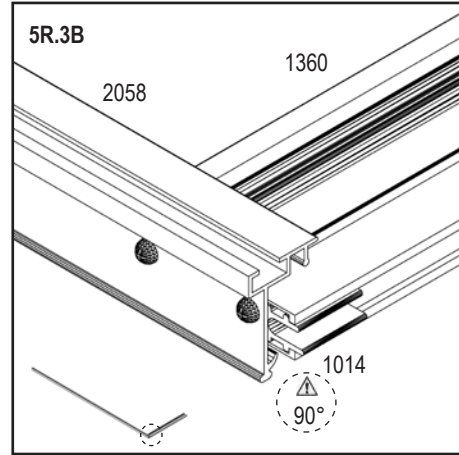
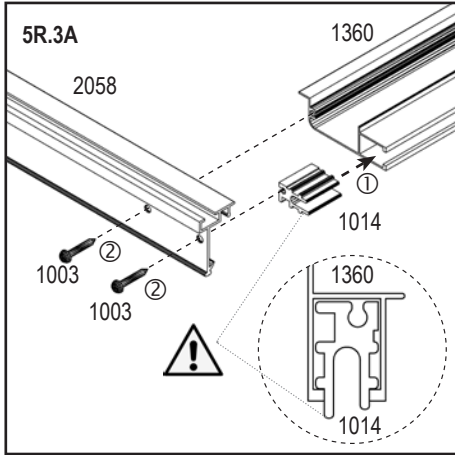
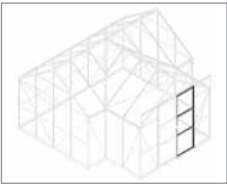

Important! Go to Exactly square

# 5\_1R

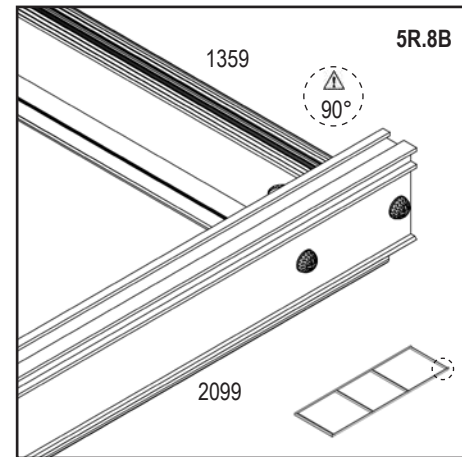
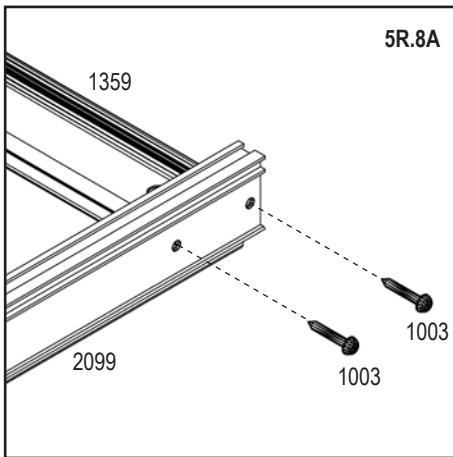
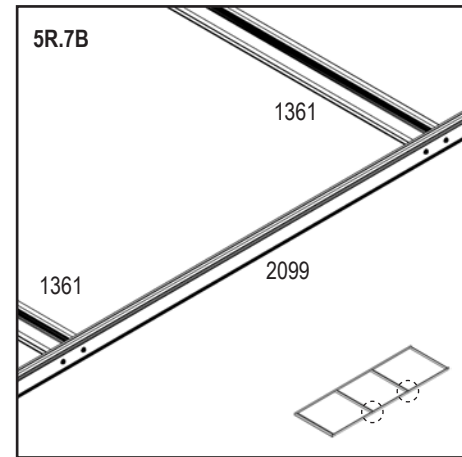
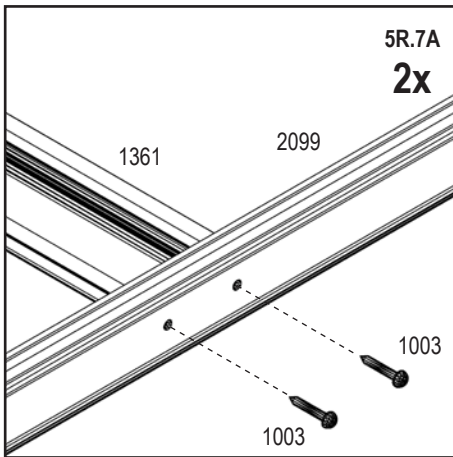
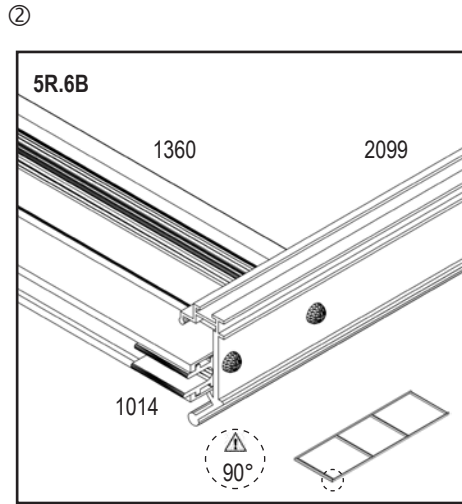
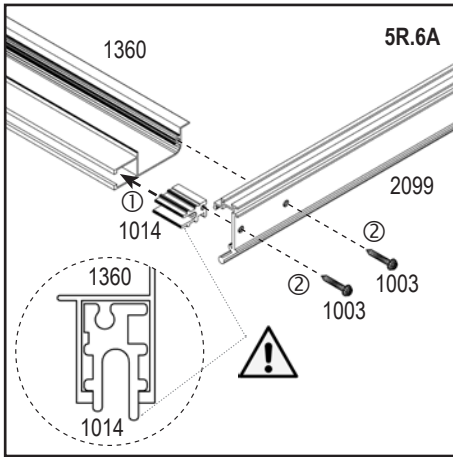

! Important! 90° Exactly square

# 5\_1R

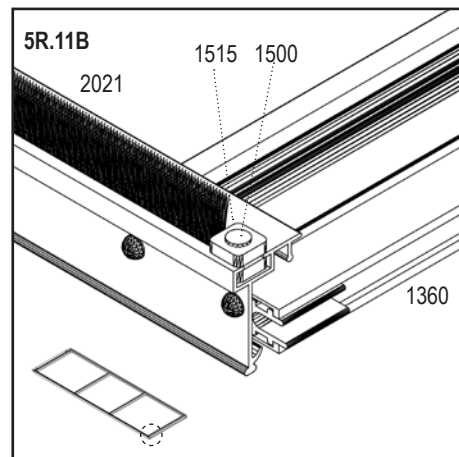
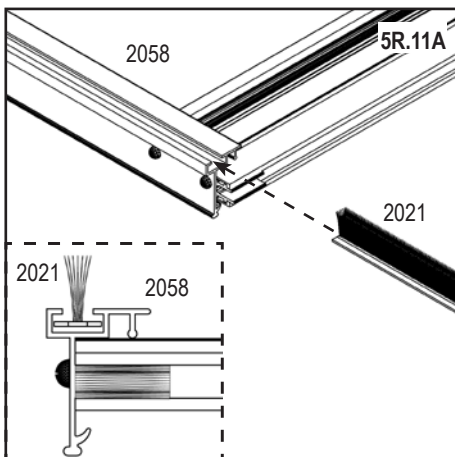
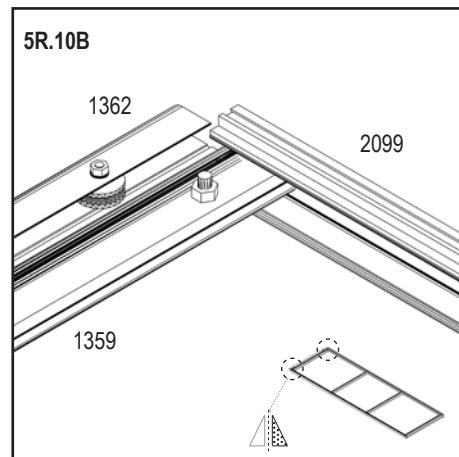
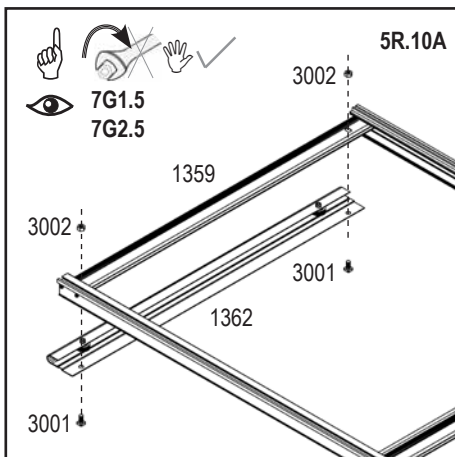
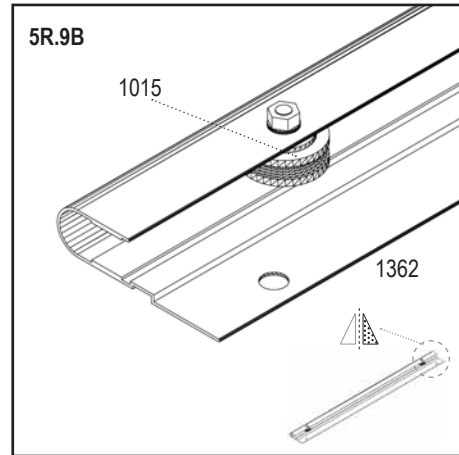
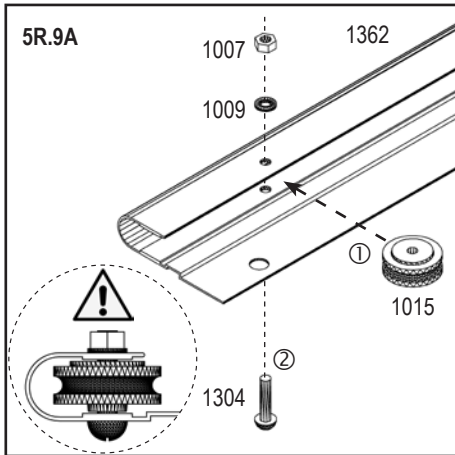

Important!



Important Tip



Adjust by Hand



Mirror of

# 5\_2

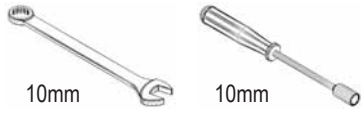
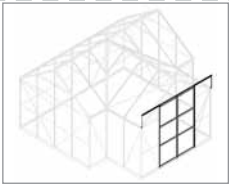

1002 2x		5001 1x	
1310 2x		5002 1x	
1347 2x		6060 2x	
2043 2x		7399 1x	
3001 8x		{S4} 1x	
3002 9x		{S5L} 1x	
4201 2x		{S5R} 1x	

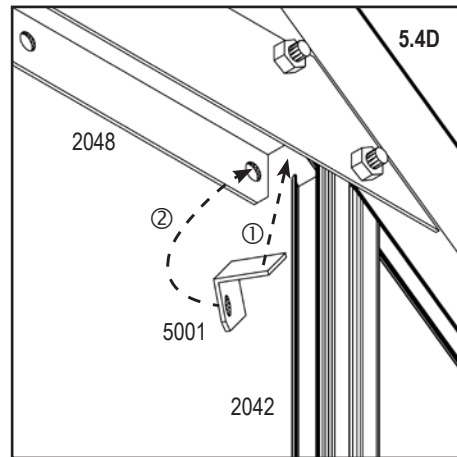
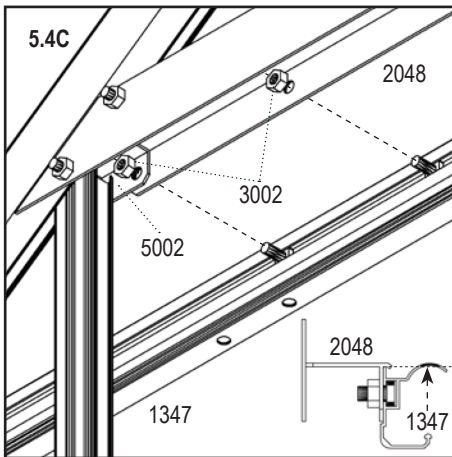
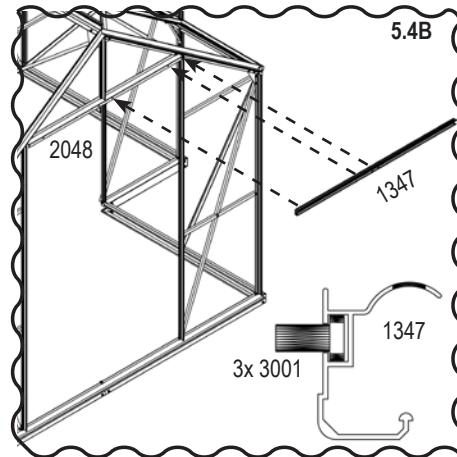
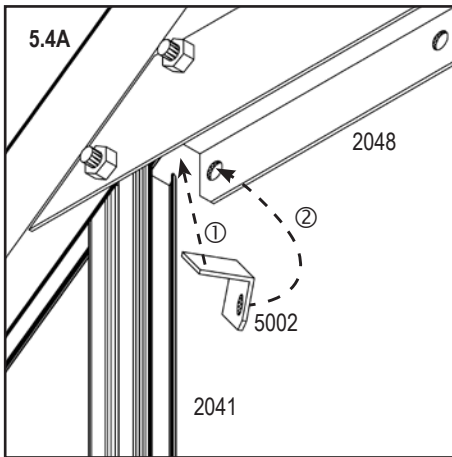
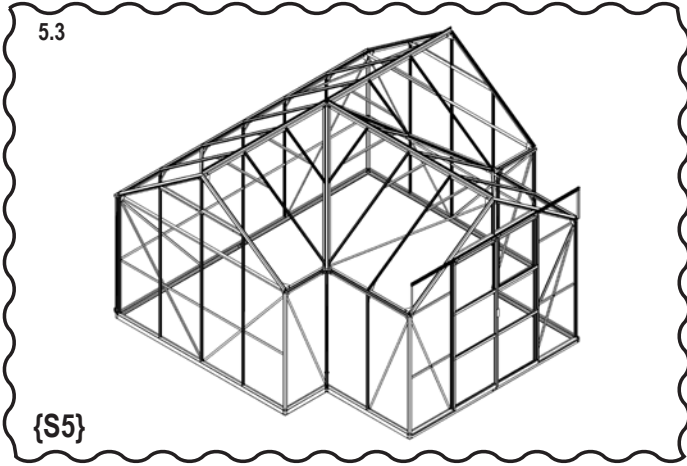

# 5\_2

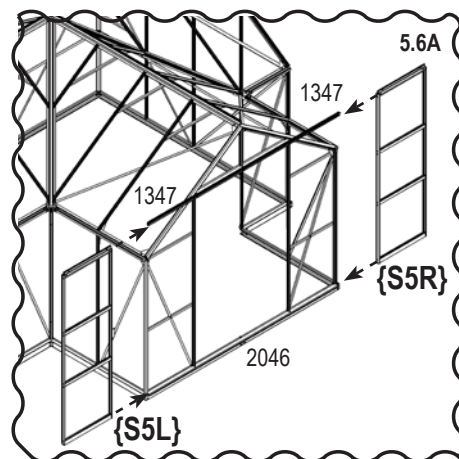
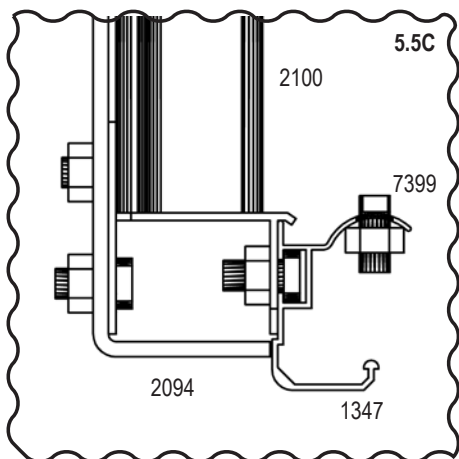
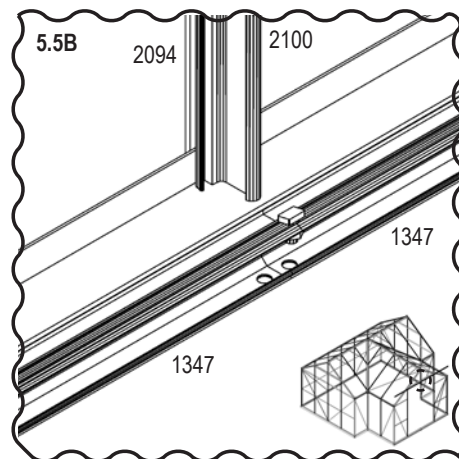
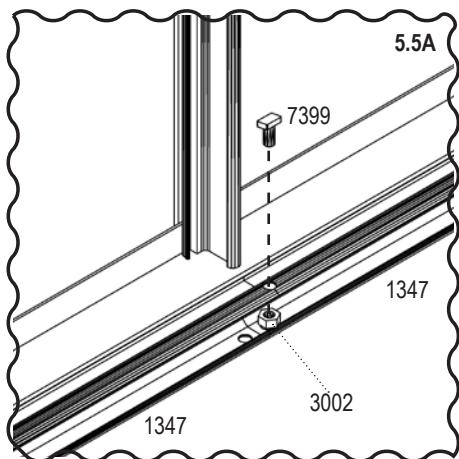
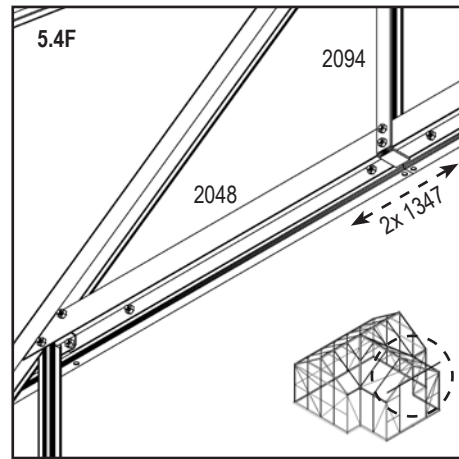
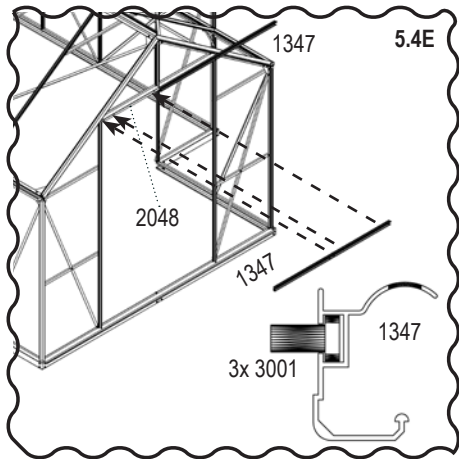

# 5\_2

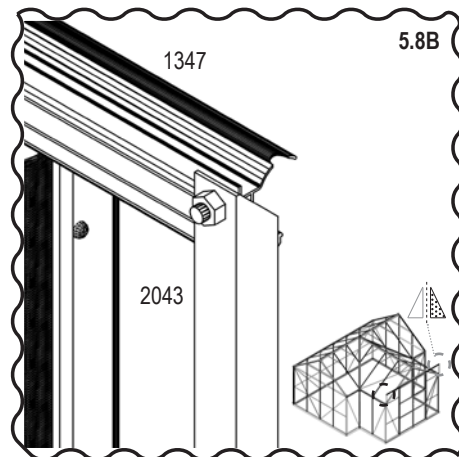
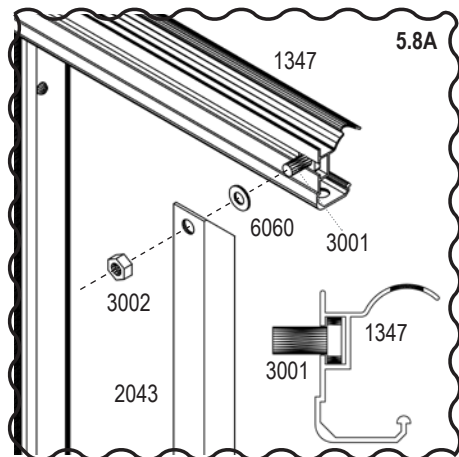
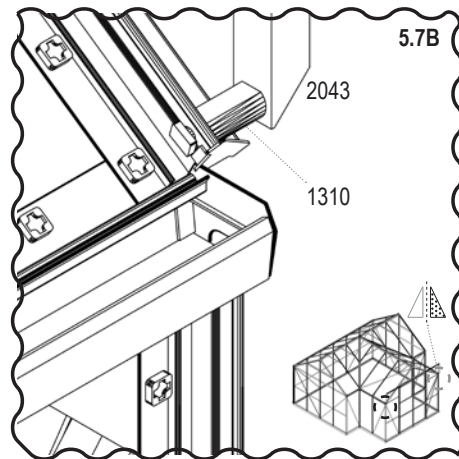
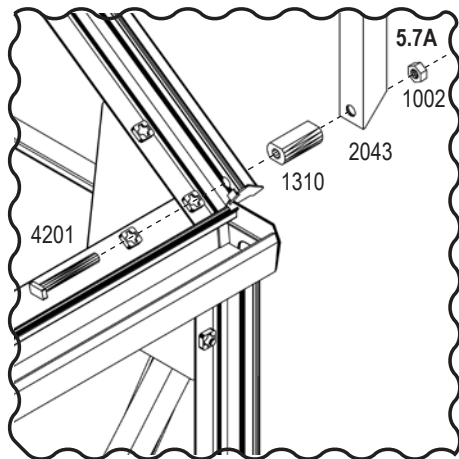
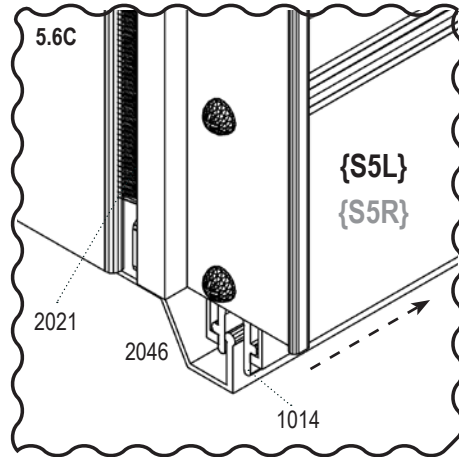
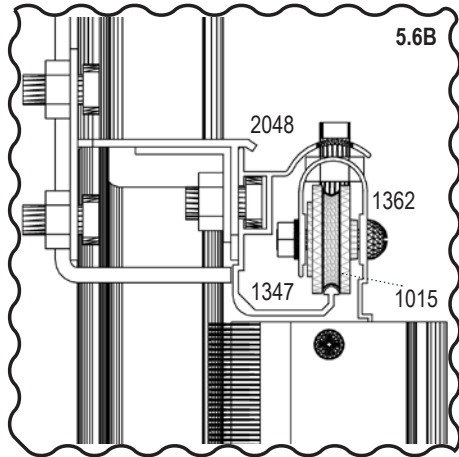

Mirror of

## 5\_2

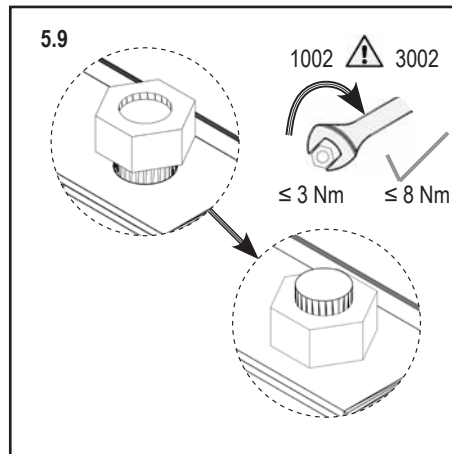

# 6

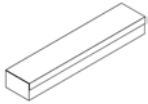
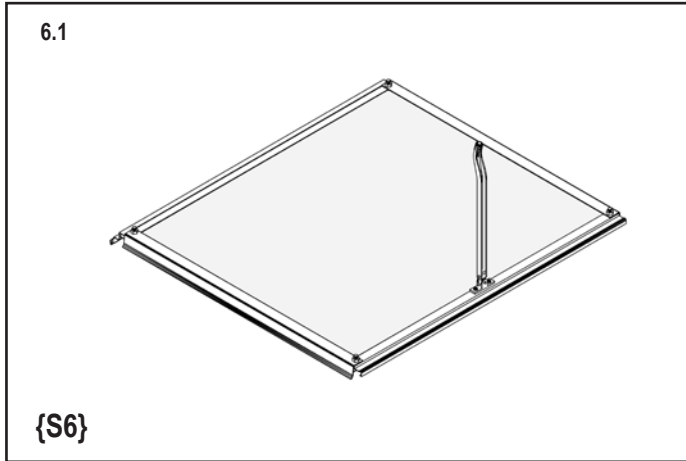
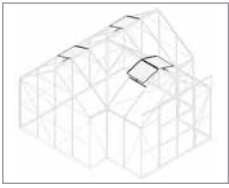

SIR,SLT,SSD, 2/6							
1006 6x 4		1064 1x 4		1067 1x 4		3002 6x 4	
1019 1x 4		1065 2x 4		2016 2x 4		7399 2x 4	
1063 1x 4		1066 1x 4		3001 4x 4			

G			
Art. No.	mm		
R	600 x 544	1x	

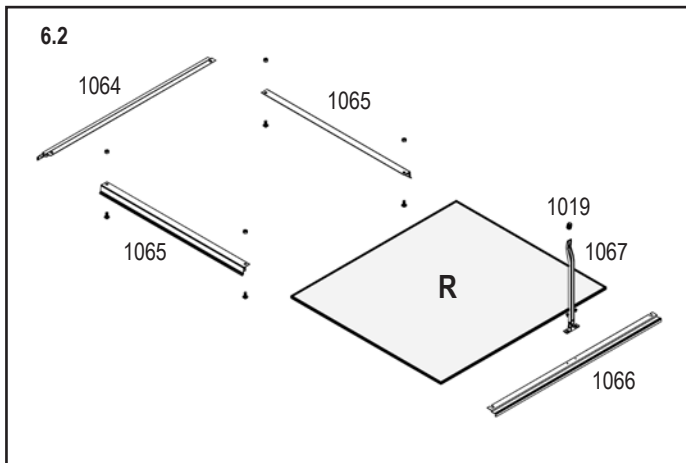





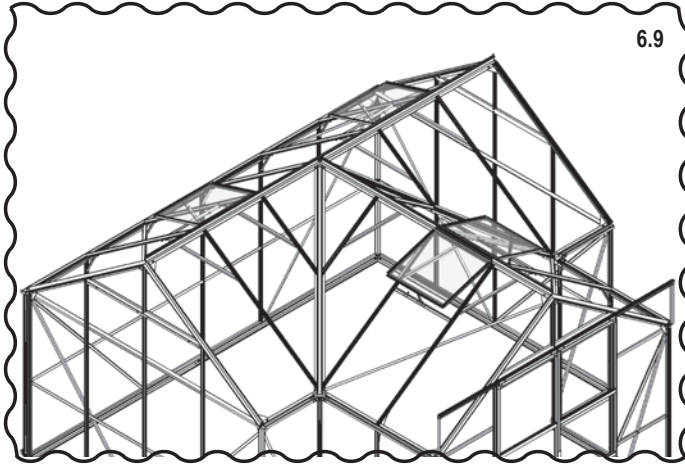
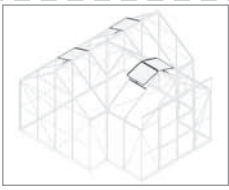

## 6\_1

- Ⓔ Please refer to the glazing instructions which are included together with the glazing panes.
- Ⓓ Bitte beachten Sie die Verglasungsanleitung, die den Verglasungsscheiben beiliegt.
- Ⓕ Veuillez vous référer aux instructions relatives au vitrage qui sont fournies avec les vitres.
- Ⓖ Raadpleeg de beglazingsinstructies die samen met de ruiten worden geleverd.
- Ⓕ Se venligst glasvejledning, som følger med ruderne.
- Ⓔ Se glasningsanvisningarna som medföljer glasrutorna.
- Ⓖ Se instruksjonene for innglassing som følger med glassene.
- Ⓕ Tutustu lasitusohjeisiin, jotka toimitetaan lasien mukana.
- Ⓕ Consultare le istruzioni per l'installazione dei vetri fornite insieme alle lastre di vetro.
- Ⓒ Řiďte se pokyny pro zasklívání, které jsou součástí dodávky zasklívacích skel.
- Ⓖ Należy zapoznać się z instrukcją szklenia, która jest dołączona do szyb.
- Ⓔ Upoštevajte navodila za zasteklitev, ki so priložena zasteklitvenim ploščam.
- Ⓕ Kérjük, olvassa el az üvegezési útmutatót, amelyet az üvegezéshez mellékeltek.
- Ⓕ Molimo pogledajte upute za ostakljenje koje su priložene zajedno sa staklenim pločama.
- Ⓔ Molimo pogledajte upute za zastakljivanje koje su priložene uz stakla.
- Ⓕ Vă rugăm să consultați instrucțiunile de aplicare a geamurilor, care sunt incluse împreună cu geamurile.
- Ⓔ Prečítajte si návod na zasklievanie, ktorý je súčasťou dodávky zasklievacích skiel.
- Ⓕ Пожалуйста, ознакомьтесь с инструкцией по остеклению, которая прилагается к стеклопакетам.
- Ⓕ Будь ласка, зверніться до інструкцій зі скління, які додаються до склопакетів.

# 6\_2

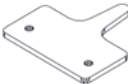

1006 4x 4		3002 2x 4	
1063 1x 4		7399 2x 4	
2016 2x 4		{S6} 1x 4	

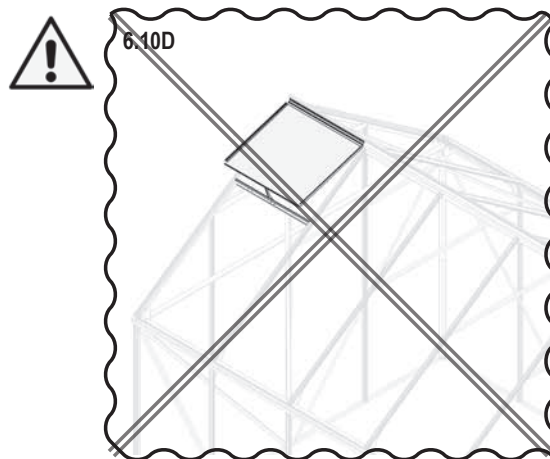
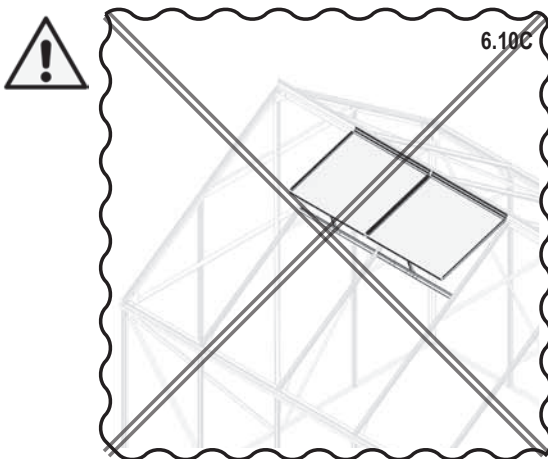
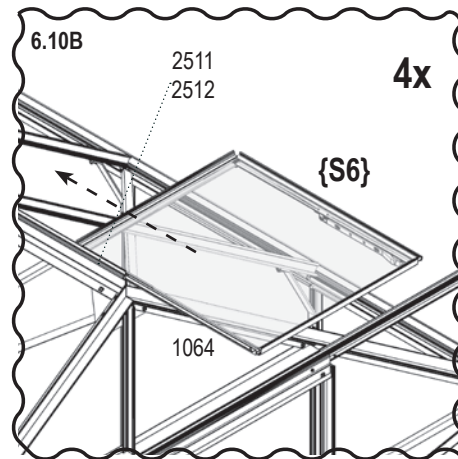
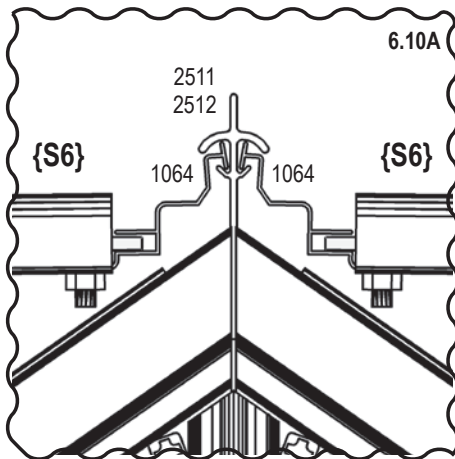

# 6\_2

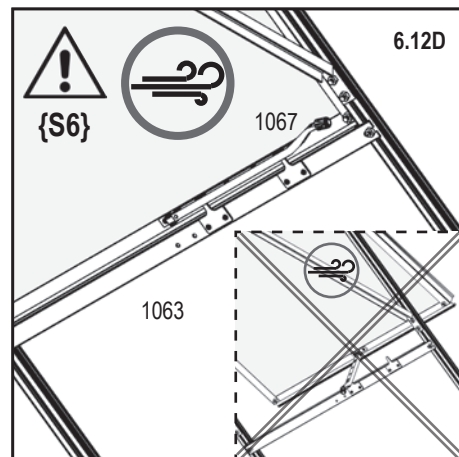
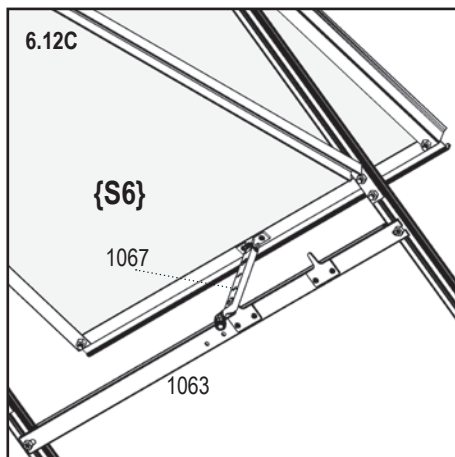
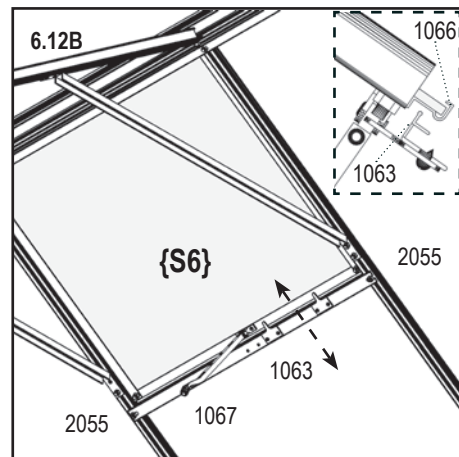
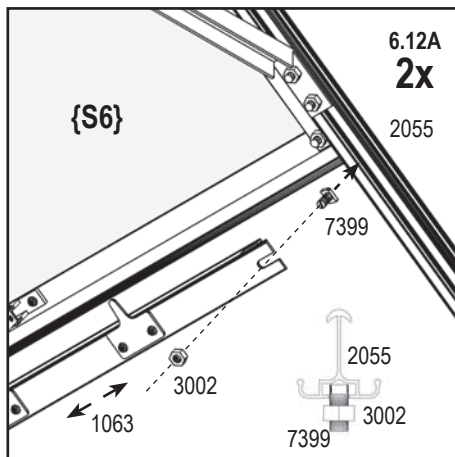
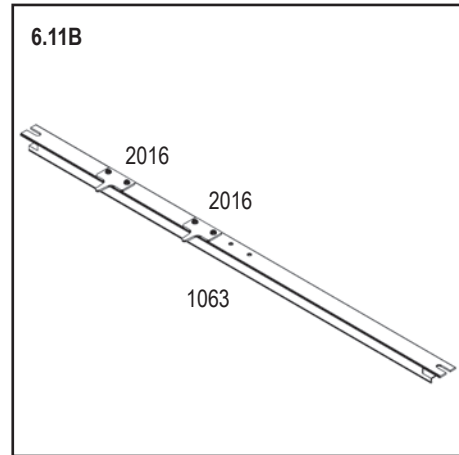
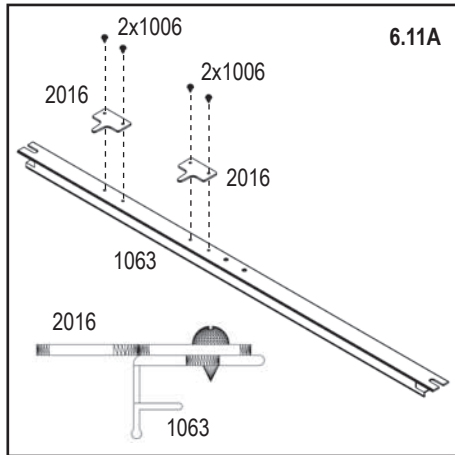

# 7

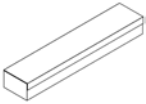
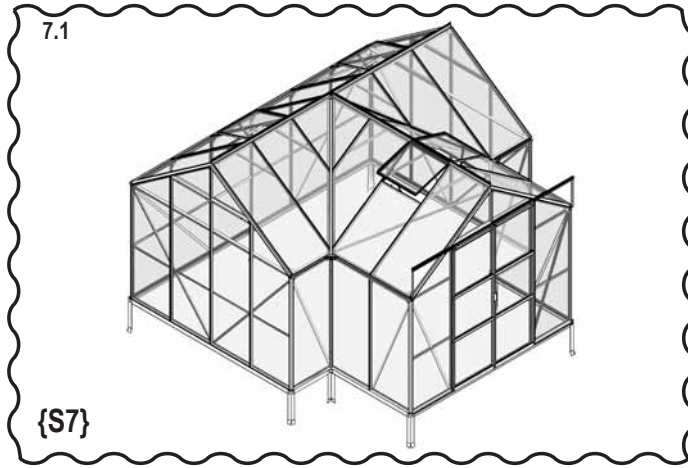
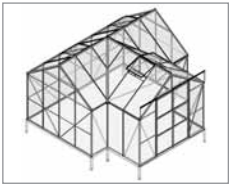

SIR,SLT,SSD, 2/6	
1020 1x	

SIR,SLT,SSD, 6/6			
6515 14x		6519 8x	
6516 52x		6520 4x	
6517 8x		6521 6x	
6518 8x			

## 7

- Ⓔ Please refer to the glazing instructions which are included together with the glazing panes.
- Ⓓ Bitte beachten Sie die Verglasungsanleitung, die den Verglasungsscheiben beiliegt.
- Ⓕ Veuillez vous référer aux instructions relatives au vitrage qui sont fournies avec les vitres.
- Ⓖ Raadpleeg de beglazingsinstructies die samen met de ruiten worden geleverd.
- Ⓕ Se venligst glasvejledning, som følger med ruderne.
- Ⓔ Se glasningsanvisningarna som medföljer glasrutorna.
- Ⓖ Se instruksjonene for innglassing som følger med glassene.
- Ⓕ Tutustu lasitusohjeisiin, jotka toimitetaan lasien mukana.
- Ⓖ Consultare le istruzioni per l'installazione dei vetri fornite insieme alle lastre di vetro.
- Ⓒ Řiďte se pokyny pro zasklívání, které jsou součástí dodávky zasklívacích skel.
- Ⓖ Należy zapoznać się z instrukcją szklenia, która jest dołączona do szyb.
- Ⓔ Upošteevajte navodila za zasteklitev, ki so priložena zasteklitvenim ploščam.
- Ⓕ Kérjük, olvassa el az üvegezési útmutatót, amelyet az üvegezéshez mellékeltek.
- Ⓕ Molimo pogledajte upute za ostakljenje koje su priložene zajedno sa staklenim pločama.
- Ⓔ Molimo pogledajte upute za zastakljivanje koje su priložene uz stakla.
- Ⓖ Vă rugăm să consultați instrucțiunile de aplicare a geamurilor, care sunt incluse împreună cu geamurile.
- Ⓔ Prečítajte si návod na zasklievanie, ktorý je súčasťou dodávky zasklievacích skiel.
- Ⓖ Пожалуйста, ознакомьтесь с инструкцией по остеклению, которая прилагается к стеклопакетам.
- Ⓔ Будь ласка, зверніться до інструкцій зі скління, які додаються до склопакетів.

# 8

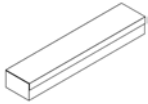
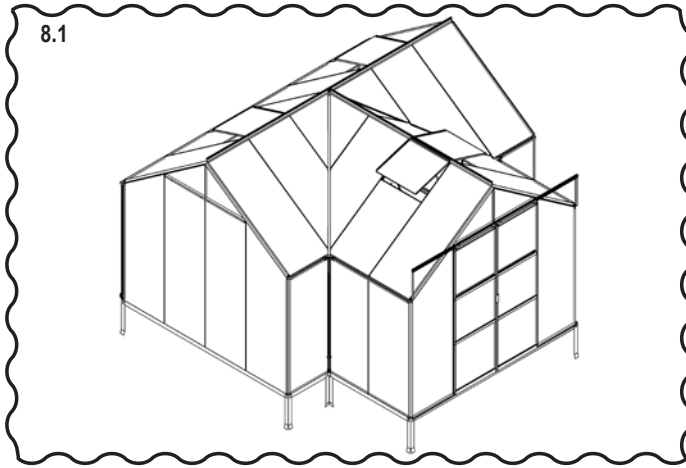
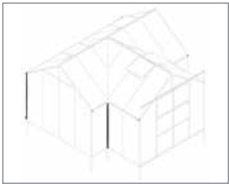

SIR,SLT,SSD, 2/6					
1003 2x		1403 1x		1413 3x	
1006 1x		1404 5x		2521 2x	
1402 3x		1408 1x			

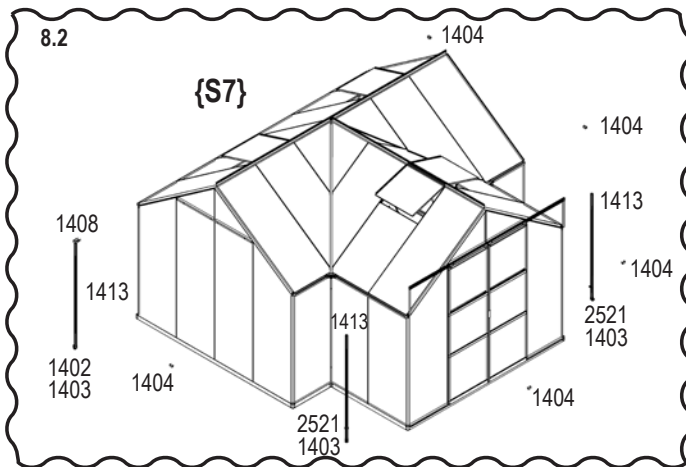

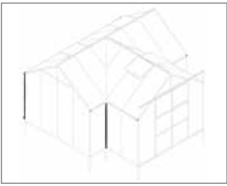

PH2

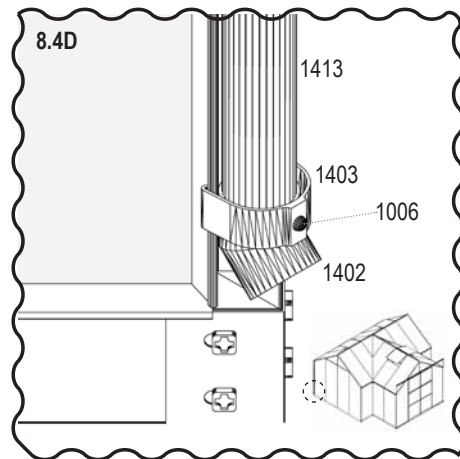
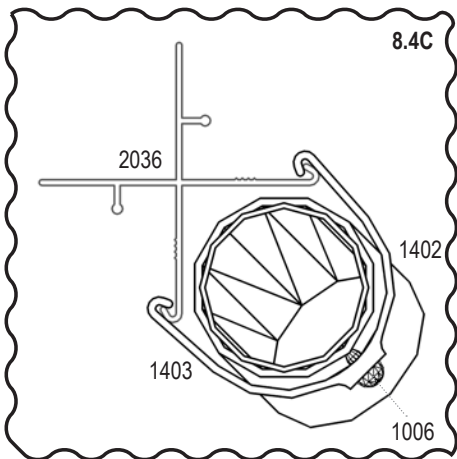
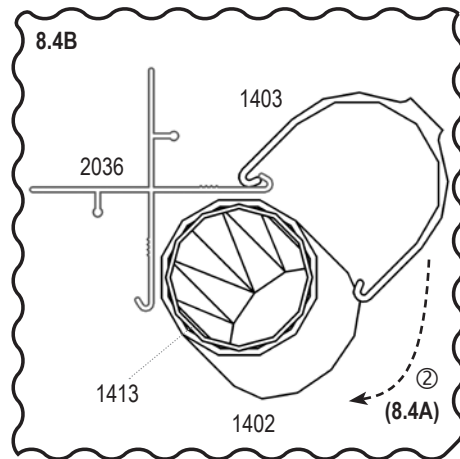
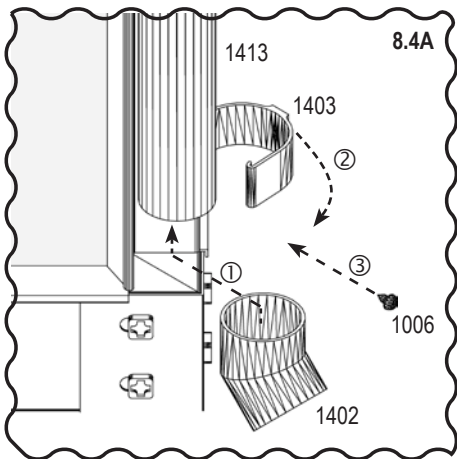
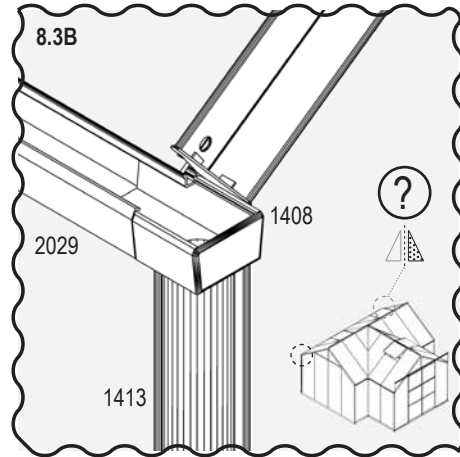
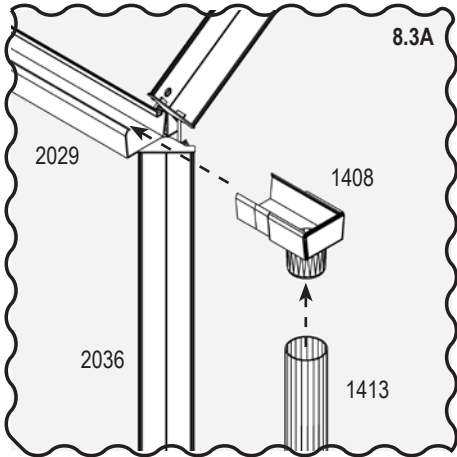

Alternative options

Mirror of

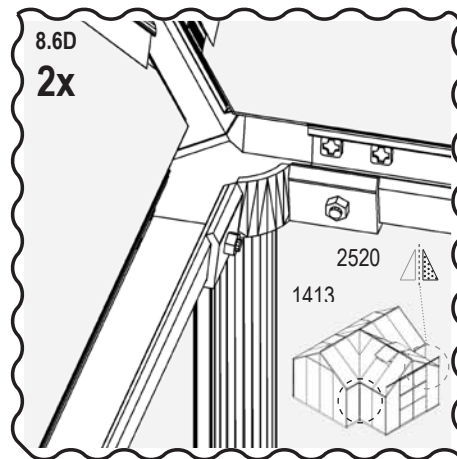
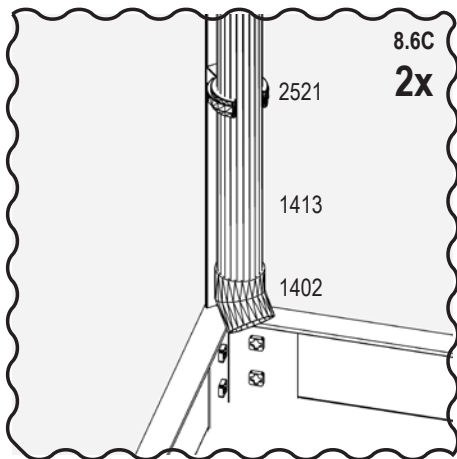
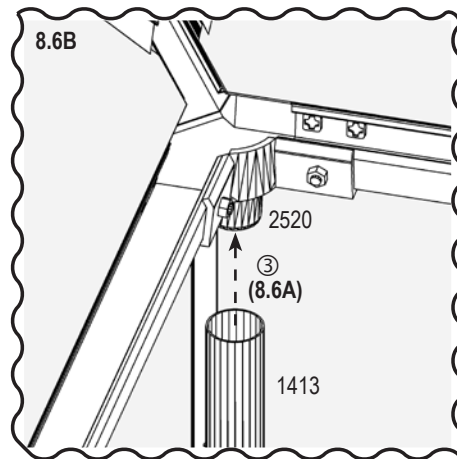
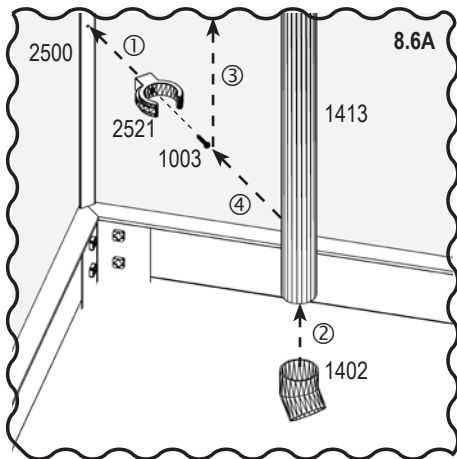
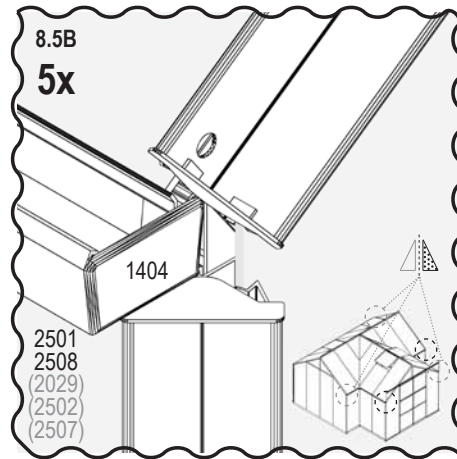
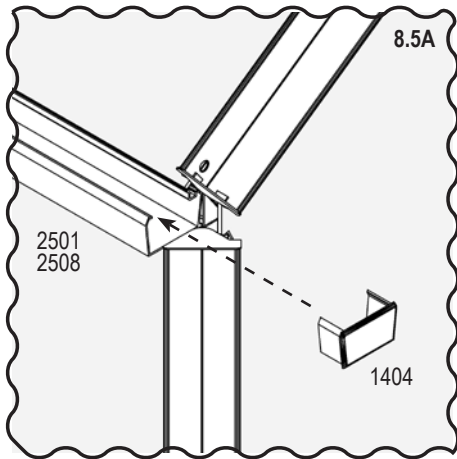

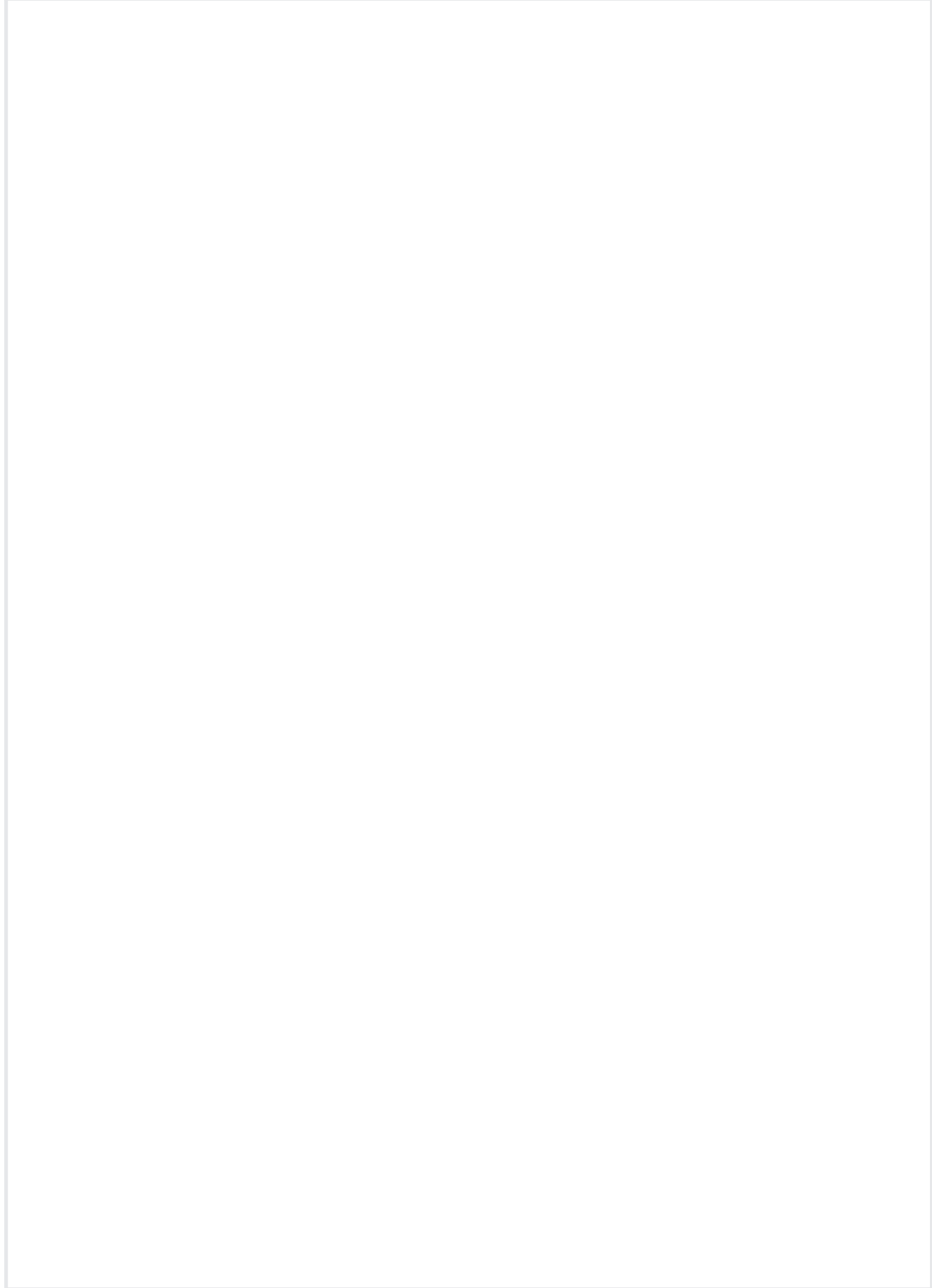
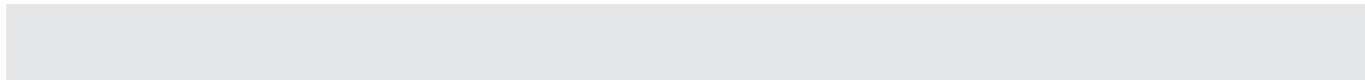



E.P.H. Schmidt u. Co. GmbH  
Hoefkerstrasse 30  
44149 Dortmund  
Postfach 170163  
44060 Dortmund  
Deutschland  
Tel.: +49 231 941655 0  
Fax: +49 231 941655 99  
[www.eph-schmidt.de](http://www.eph-schmidt.de)  
[verkauf@eph-schmidt.de](mailto:verkauf@eph-schmidt.de)

OPJ A/S  
Volderslevvej 36 A  
5260 Odense S  
Danmark  
Tel.: +45 66 15 10 30  
Fax: +45 66 15 00 84  
[www.opj.dk](http://www.opj.dk)  
[opj@opj.dk](mailto:opj@opj.dk)